

TOYOTA

L,2L,2L-T

ENGINE

REPAIR MANUAL

Aug., 1984

TL
230.5
.T69
1987

Pub.No.3625

FOREWORD

This repair manual has been prepared to provide information covering general service repairs for the L and 2L engines equipped on the TOYOTA CRESSIDA, CROWN, HIACE, HILUX TOYOACE and BUV.

Applicable models:

- LX 70 series
- LS 120 series
- LH 11, 51, 61, 71 series
- LN 50, 55, 56, 60, 65 series
- LY 31 series
- LF 30 series
- LJ70 series

The sections which contain specifically different operations for the 2L-T engine equipped on the below-listed models of the TOYOTA CRESSIDA are listed at the back of this manual.

Applicable models:

- LX 71 series

All information contained in this manual is the most up-to-date at the time of publication. However specifications and procedures are subject to change without notice.

TOYOTA MOTOR CORPORATION

TOYOTA L, 2L ENGINE REPAIR MANUAL

INTRODUCTION	IN
ENGINE MECHANICAL	EM
FUEL SYSTEM	FU
COOLING SYSTEM	CO
LUBRICATION SYSTEM	LU
STARTING SYSTEM	ST
CHARGING SYSTEM	CH
BODY ELECTRICAL SYSTEM	BE
SERVICE SPECIFICATIONS	A
STANDARD BOLT TIGHTENING TORQUE	B
SST	C

SUPPLEMENT 2L-T ENGINE

NOTE: The following sections contain only the points which differ from the sections listed above.

ENGINE MECHANICAL	EM
FUEL SYSTEM	FU
SERVICE SPECIFICATIONS	A

MOUNT GRAVATT COLLEGE OF T.A.F.E.
LIBRARY

Order Number

5089641-1

©1987 TOYOTA MOTOR CORPORATION
All rights reserved. This book may not be reproduced or copied, in whole or in part, without the written permission of Toyota Motor Corporation.

INTRODUCTION

	Page
HOW TO USE THIS MANUAL	IN-2
IDENTIFICATION INFORMATION	IN-4
GENERAL REPAIR INSTRUCTIONS	IN-4
ABBREVIATIONS USED IN THIS MANUAL	IN-6

IN

HOW TO USE THIS MANUAL

To assist in finding your way through this manual, the Section Title and major heading are given at the top of every page.

An **INDEX** is provided on the 1st page of each section to guide you to the item to be repaired.

At the beginning of each section, **PRECAUTIONS** are given that pertain to *all* repair operations contained in that section. *Read these precautions before starting any repair task.*

TROUBLESHOOTING tables are included for each system to help you diagnose the system problem and find the cause. The repair for each possible cause is referenced in the remedy column to quickly lead you to the solution.

REPAIR PROCEDURES

Most repair operations begin with an overview illustration. It identifies the components and shows how the parts fit together.

Example:

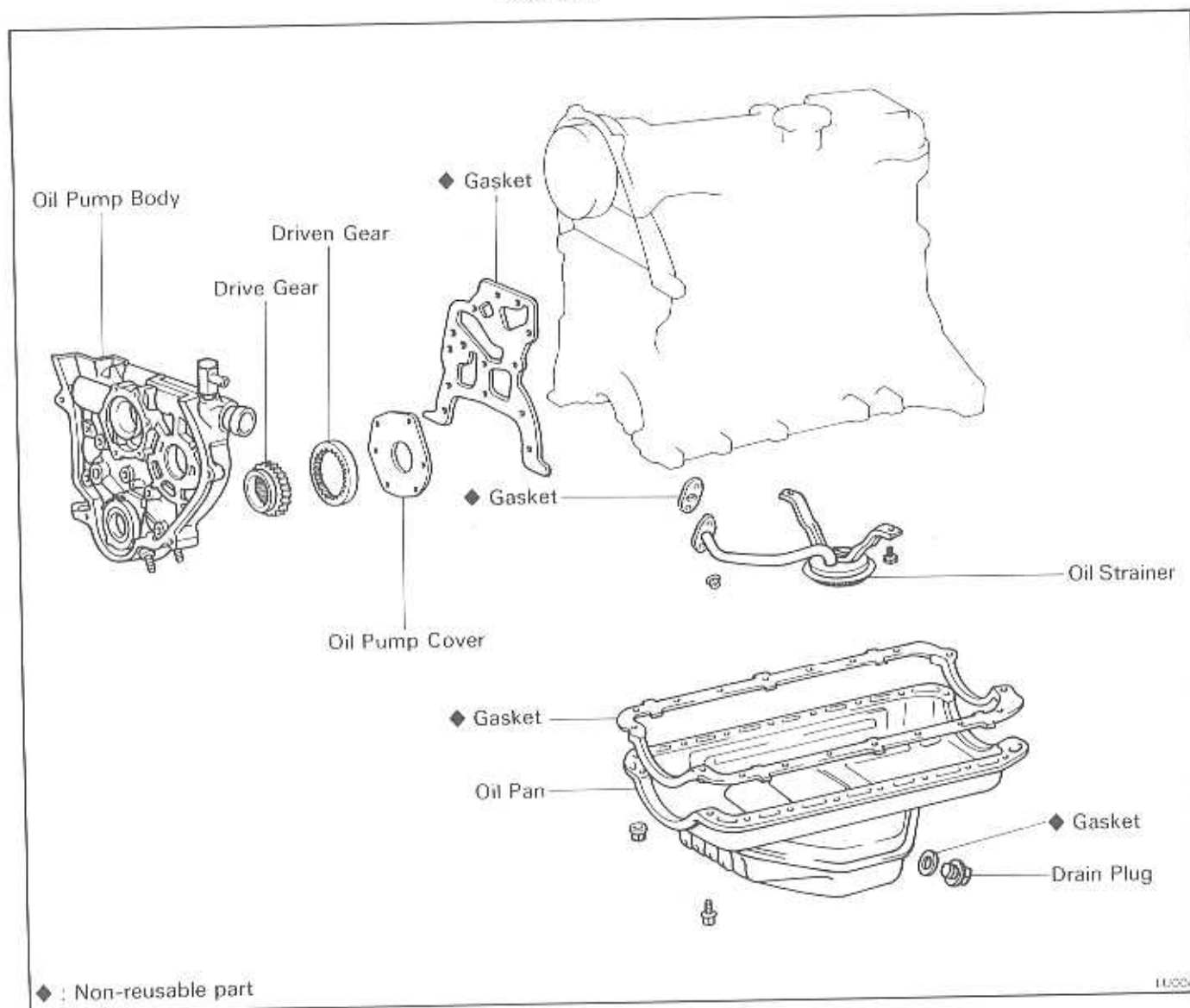

The procedures are presented in a step-by-step format:

- The illustration shows *what* to do and *where* to do it.
- The task heading tells *what* to do.
- The detailed text tells *how* to perform the task and gives other information such as specifications and warnings.

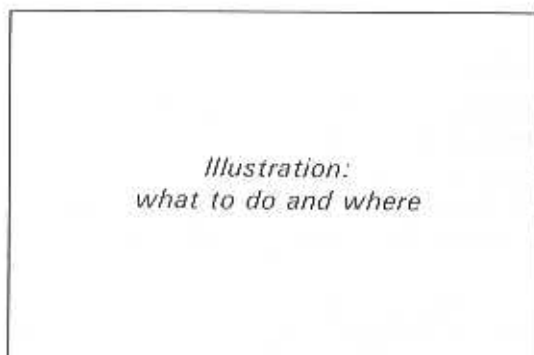

Example:

INSTALL OIL STRAINER ← *Task heading: what to do*

Install a new gasket and the oil strainer with the two bolts and two nuts. Torque the bolts and nuts. ← *Detail text: how to do it*

Torque: 120 kg-cm (9 ft-lb, 12 N·m) ← *Specification*

This format enables the experienced technician to have a FAST TRACK. He can read the task headings and only refer to the detailed text when he needs it. Important specifications and warnings always stand out in bold type.

REFERENCES

References have been kept to a minimum. However, when they are required you are given the *page* to go to.

SPECIFICATIONS

Specifications are presented in bold type throughout the text in the applicable step. You never have to leave the procedure to look up your specifications. All specifications are also found in Appendix A, Specifications, for quick reference.

WARNINGS, CAUTIONS, NOTES:

- **WARNINGS** are presented in bold type, and indicate there is a possibility of injury to you or other people.
- **CAUTIONS** are also presented in bold type, and indicate there is a possibility of damage to the components being repaired.
- **NOTES** are separated from the text but do not appear in bold. They provide additional information to more efficiently help you perform the repair.

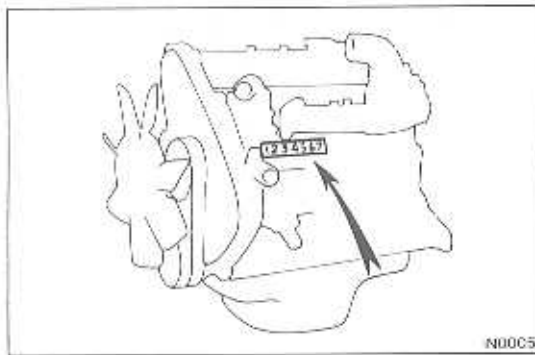

N0005

IDENTIFICATION INFORMATION

ENGINE SERIAL NUMBER

The engine serial number is stamped on the left side of the cylinder block.

GENERAL REPAIR INSTRUCTIONS

1. Use fender, seat and floor covers to keep the vehicle clean and prevent damage.
2. During disassembly, keep parts in order to facilitate reassembly.
3. Observe the following:
 - (a) Before performing electrical work, disconnect the cable from the battery terminal.
 - (b) If it is necessary to disconnect the battery for inspection or repair, always disconnect the cable from the negative (-) terminal which is grounded to the vehicle body.
 - (c) To prevent damage to the battery terminal post, loosen the terminal nut and raise the cable straight up without twisting or prying it.
 - (d) Clean the battery terminal posts and cable terminals with a shop rag. Do not scrape them with a file or such.
 - (e) Install the cable terminal to the battery post with the nut loose, and tighten the nut after installation. Do not use a hammer or such to tap the terminal onto the post.
 - (f) Be sure the cover for the positive (+) terminal is properly in place.
4. Check hose and wiring connectors to make sure that they are secure and correct.
5. Non-reusable parts
 - (a) Always replace cotter pins, gaskets, O-rings and oil seals etc. with new ones.
 - (b) Parts which cannot be reused are indicated by the symbol "◆".

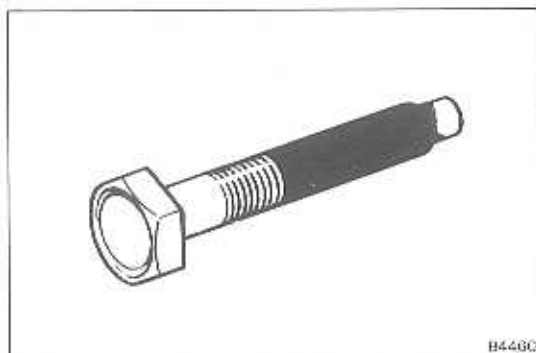

B4400

6. Precoated Parts

Precoated parts are parts such as nuts and bolts which are coated with a seal lock adhesive at the factory.

- (a) If a precoated part is retightened, loosened or caused to move in any way, it must be recoated with the specified adhesive.

- (b) Recoating of Precoated Parts
 - (1) Clean off the old adhesive from the part's threads.
 - (2) Dry with compressed air.
 - (3) Apply the specified seal lock adhesive to the part's threads.
 - (c) Precoated parts are indicated in the component illustrations by the "★" symbol.
7. When necessary, use a sealer on gaskets to prevent leaks.
 8. Carefully observe all specifications for bolt tightening torques. Always use a torque wrench.
 9. Use of special service tools (SST) may be required, depending on the nature of the repair. Be sure to use SST where specified and follow the proper work procedure. A list of SST can be found at the back of this manual.
 10. When replacing fuses, be sure the new fuse is the correct amperage. DO NOT exceed the fuse amp rating or use one of a lower rating.
 11. Care must be taken when jacking up and supporting the vehicle. Be sure to lift and support the vehicle at the proper locations.
 - (a) If the vehicle is to be jacked up only at the front or rear end, be sure to block the wheels in order to ensure safety.
 - (b) After the vehicle is jacked up, be sure to support it on stands. It is extremely dangerous to do any work on the vehicle raised on one jack alone, even for a small job that can be finished quickly.
 12. Observe the following precautions to avoid damaging the parts:
 - (a) When disconnecting vacuum hoses, pull on the end of the hose, not the middle.
 - (b) When separating electrical connectors, pull on the connector itself, not the wires.
 - (c) Be careful not to drop electrical components, such as sensors or relays. If they are dropped on a hard floor, they should be replaced and not reused.
 - (d) When steam cleaning an engine, protect the air filter and injection pump from water.
 - (e) Never use an impact wrench to remove or install thermo switches or thermo sensors.
 - (f) When checking continuity at the wire connector, insert the tester probe carefully to prevent terminals from bending.
 - (g) When using a vacuum gauge, never force the hose onto a connector that is too large. Use a step-down adapter instead. Once the hose has been stretched, it may leak.

ABBREVIATIONS USED IN THIS MANUAL

A/C	Air Conditioner
ACSD	Automatic Cold Start Device
A/T	Automatic Transmission
BTDC	Before Top Dead Center
EX	Exhaust
Ex.	Except
HAC	High Altitude Compensation
IN	Intake
LH	Left-hand
LHD	Left-hand Drive
MP	Multipurpose
M/T	Manual Transmission
O/S	Oversize
PS	Power Steering
RH	Right-hand
RHD	Right-hand Drive
SST	Special Service Tool
STD	Standard
T	Tightening Torque
TDC	Top Dead Center
U/S	Undersize
w/	With
w/o	Without

ENGINE MECHANICAL

	Page
DIESEL ENGINE DIAGNOSIS	EM-2
DIESEL ELECTRICAL SYSTEM DIAGNOSIS	EM-11
ENGINE TUNE-UP	EM-14
COMPRESSION CHECK	EM-19
TIMING BELT	EM-20
Components	EM-20
Removal of Timing Belt	EM-20
Inspection of Components	EM-24
Installation of Timing Belt	EM-25
CYLINDER HEAD	EM-31
Components	EM-31
Removal of Cylinder Head	EM-32
Disassembly of Cylinder Head	EM-35
Inspection, Cleaning and Repair of Cylinder Head Components	EM-36
Replacement of Camshaft Oil Seal	EM-44
Assembly of Cylinder Head	EM-45
Installation of Cylinder Head	EM-46
CYLINDER BLOCK	EM-50
Components	EM-50
Disassembly of Cylinder Block	EM-51
Inspection of Cylinder Block	EM-55
Disassembly of Piston and Connecting Rod Assembly	EM-56
Inspection of Piston and Connecting Rod Assembly	EM-57
Replacement of Connecting Rod Bushing	EM-60
Inspection and Repair of Crankshaft	EM-61
Boring of Cylinders	EM-62
Replacement of Crankshaft Oil Seals	EM-63
Assembly of Piston and Connecting Rod Assembly	EM-64
Installation of Crankshaft, Piston and Connecting Rod Assembly	EM-66
Assembly of Cylinder Block	EM-67

EM

DIESEL ENGINE DIAGNOSIS

1. GENERAL

Diesel engine problems are usually caused by the engine or fuel system. The injection pump is very rarely the cause of fuel system problems.

Before beginning fuel system tests, first check that the engine compression, valve timing and other major systems are within specification.

The following fuel system diagnosis procedures are applicable to Toyota 1C, 1C-T, 2C, L, 2L and 2L-T engines equipped with the distributor type injection pump.

2. PRELIMINARY CHECKS

- (a) Before performing fuel system checks, check that the engine is in good running condition. If necessary, first check the compression, timing and major components or systems.
- (b) Check the air filter and clean or replace as needed.
- (c) Check that there is sufficient fuel in the tank.
- (d) Check if the fuel is contaminated with gasoline or other foreign elements. Only good-quality diesel fuel should be used.
- (e) Bleed air from the system by pumping the priming pump 30 – 40 times.
- (f) Check for water in the fuel filter and fuel tank and drain as necessary.
- (g) If the engine will not crank or if it cranks slowly, first troubleshoot the electrical system.

PRECAUTION

1. The basic troubleshooting procedures for the diesel engine (valve clearance, compression, bearings, valves, pistons, etc.) are the same checks you would make for a gasoline engine.
2. The repair of an injection pump requires considerable skill and use of a special test bench.

ENGINE WILL NOT CRANK

(Possible Cause)	(Check Procedure and Correction Method)
1. LOOSE OR CORRODED BATTERY CABLES	Check cables from battery to starter and make necessary repairs.
2. DISCHARGED BATTERY	Check alternator output and the drive belt. Repair as necessary.
3. INOPERATIVE STARTER	Check for battery voltage at starter terminals 30 and 50. If Okay, see STARTING SYSTEM, page (ST-15 or 16) for repair procedure.

ENGINE CRANKS SLOWLY—WILL NOT START

NOTE: Minimum cranking speed: Cold M/T 100 rpm
A/T 110 rpm
Hot 150 rpm

(Possible Cause)	(Check Procedure and Correction Method)
1. LOOSE OR CORRODED BATTERY CABLES	Refer to items 1 and 2 of ENGINE WILL NOT CRANK.
2. DISCHARGED BATTERY	
3. IMPROPER ENGINE OIL	Check engine oil. If improper viscosity, drain and refill with oil of viscosity recommended by manufacturer.

ENGINE CRANKS NORMALLY BUT WILL NOT START

(Possible Cause)

(Check Procedure and Correction Method)

1. NO FUEL TO NOZZLE

Loosen any one injection pipe union nut from its nozzle holder.
Crank the engine for about 5 seconds while confirming that fuel is being discharged from the pipe. If fuel is coming out, begin diagnosis from item 4. If not, begin from item 2.

2. NO FUEL CUT SOLENOID OPERATION

With starter switch turned ON, check for fuel cut solenoid operation noise (clicking sound) while repeatedly connecting and disconnecting fuel cut solenoid.
If no noise, check if there are 12 volts to the solenoid when the starter switch is ON.
If 12 volts are confirmed, fuel cut solenoid is faulty and should be replaced. If not 12 volts, refer to ELECTRICAL DIAGNOSIS and make necessary repairs.

3. NO FUEL INTO INJECTION PUMP

Disconnect inlet hoses to fuel filter and feed clean fuel from separate container directly into fuel pump. If engine starts, either the fuel filter or line between fuel tank and filter is clogged and should be repaired accordingly.
If engine still does not start (no fuel intake), check fuel line between filter and pump.
If normal, pump is faulty and should be replaced.
NOTE: When feeding fuel directly into pump, keep container at same level as vehicle fuel tank.

4. INOPERATIVE PRE-HEATING OPERATION

With the starter switch turned ON and the glow plug indicator light illuminated, check that there are 6 volts applied to the glow plug.
If not, refer to ELECTRICAL DIAGNOSIS and repair as necessary.

5. FAULTY GLOW PLUG OPERATION

Check glow plug for continuity.
If no continuity, a broken wire is indicated and the glow plug should be replaced.

6. FUEL LEAKAGE FROM
INJECTION PIPE

Check for loose unions or cracks.
If leaking, tighten to standard torque or, if necessary, replace pipe(s).

7. IMPROPER INJECTION
TIMING

Turn crankshaft clockwise to where either No. 1 or No. 4 piston is at TDC and, after releasing cold start advance system (LX), check plunger stroke with SST.

Standard:

L		0.94 – 1.06 mm (0.0370 – 0.0417 in.)
2L	w/o ACSD	1.06 – 1.22 mm (0.0417 – 0.0480 in.)
	w/ ACSD	0.82 – 0.98 mm (0.0323 – 0.0386 in.)
2L-T		0.75 – 0.87 mm (0.0295 – 0.0343 in.)

If not at the standard indicated above, injection pump is not adjusted properly.

NOTE: If injection timing is off more than 10°, it could indicate a slipped timing belt.

8. IMPROPER FAST IDLE

Measure timer piston stroke and fast idle lever opening angle with injection pump tester.

9. FAULTY NOZZLE OR
NOZZLE HOLDER

Check injection pressure with nozzle tester.

Standard pressure:

L, 2L (ex. LS Hong Kong & Singapore), 2L-T	105 – 125 kg/cm ² (1,493 – 1,778 psi, 10,297 – 12,258 kPa)
2L (LS Hong Kong & Singapore)	145 – 168 kg/cm ² (2,062 – 2,389 psi, 14,220 – 16,475 kPa)

If not within standard indicated above, nozzle adjustment is improper and pressure should be readjusted.

If pressure cannot be adjusted to standard, replace nozzle holder assembly.

ROUGH IDLE WITH WARM ENGINE

(Possible Cause)

(Check Procedure and Correction Method)

1. IMPROPER ADJUSTMENT OF ACCELERATOR CABLE

With accelerator pedal released, check that adjusting lever is in contact with idle speed adjusting screw. Also check if accelerator cable or linkage is catching on something. If necessary, adjust so lever is in contact with screw, or make other required repairs.

2. IDLE RPM TOO LOW

Check if idle rpm is at standard indicated below.
Standard idle rpm: 700 M/T (ex. LX)
800 M/T (LX) & A/T

NOTE: If less than standard, idling would normally be rough.

If not, adjust with idle speed adjusting screw.

3. FUEL LEAKAGE

Check for leaks at the pump connections, pump distributor head bolts, nozzle holder and delivery valve.

Tighten any loose connections to specified torque or replace parts as necessary.

4. IMPROPER INJECTION TIMING

Refer to item 7 of ENGINE CRANKS NORMALLY BUT WILL NOT START, above.

5. IMPROPER OPERATION OF NOZZLE OR DELIVERY VALVE

With engine idling, loosen the union nuts of the injection pipe to each cylinder in order, and check if the idle speed changes.

If no change, a faulty cylinder is indicated. Check according to following procedure.

Faulty Nozzle or Nozzle Holder

Check injection pressure with nozzle tester.

Standard pressure:

L, 2L (ex. LS Hong Kong & Singapore), 2L-T

105 – 125 kg/cm²

(1,493 – 1,778 psi, 10,297 – 12,258 kPa)

2L (LS Hong Kong & Singapore)

145 – 168 kg/cm²

(2,062 – 2,389 psi, 14,220 – 16,475 kPa)

If pressure is not within standard indicated above, nozzle is faulty and injection pressure should be readjusted.

Faulty Delivery Valve

If injection pressure is within standard, delivery valve is defective and should be replaced.

6. NO FUEL INTO INJECTION PUMP

Refer to item 3 of ENGINE CRANKS NORMALLY BUT WILL NOT START, above.

ENGINE SUDDENLY STOPS

(Possible Cause)

(Check Procedure and Correction Method)

1. ENGINE WILL NOT RE-START

Check to see if engine re-starts according to prescribed procedure.
If not, refer to ENGINE CRANKS NORMALLY BUT WILL NOT START, above, and repair as necessary.

2. ROUGH IDLE

If idle is not stable, refer to ROUGH IDLE and repair accordingly.

3. MALFUNCTION OF FUEL CUT SOLENOID

Refer to ENGINE CRANKS NORMALLY BUT WILL NOT START, above, and check accordingly.

NOTE: No operation noise from the fuel cut solenoid may be due to loose electrical connections, so check connectors before proceeding with further repairs.

4. NO FUEL INTO INJECTION PUMP

Refer to item 3 of ENGINE CRANKS NORMALLY BUT WILL NOT START, above.

LACK OF POWER

NOTE:

1. First check that air cleaner is not clogged and engine not overheating.
2. Not applicable if customer desires output power higher than specified for that vehicle. For accuracy, adjust with a chassis dynamo.

(Possible Cause)

(Check Procedure and Correction Method)

1. IMPROPER ACCELERATOR CABLE ADJUSTMENT

With accelerator fully depressed, check that adjusting lever is in contact with maximum speed adjusting screw.
If not, adjust accordingly.

2. INSUFFICIENT NO-LOAD MAXIMUM RPM

Start engine, depress accelerator pedal to floor and check that no-load maximum rpm is within standard.
If not, adjust with maximum speed adjusting screw.

3. INTERCHANGED
OVERFLOW SCREW (OUT)
AND INLET (NO MARK)
FITTING

NOTE: Overflow screw is marked "OUT" and has an inner jet. They must not be interchanged.

4. FUEL LEAKAGE

Refer to item 3 of ROUGH IDLE WITH WARM ENGINE.

5. CLOGGED FUEL FILTER

Disconnect inlet hose from fuel filter and feed clean fuel directly into the pump. If engine condition improves, fuel filter is clogged and should be replaced.

NOTE: When feeding fuel directly into pump, keep container at same level as vehicle fuel tank.

If no increase in engine condition after replacing fuel filter, check priming pump or perform other necessary repairs.

6. IMPROPER INJECTION
TIMING

Refer to item 7 of ENGINE CRANKS NORMALLY BUT WILL NOT START.

7. FAULTY NOZZLE OR
NOZZLE HOLDER

Refer to item 9 of ENGINE CRANKS NORMALLY BUT WILL NOT START.

EXCESSIVE EXHAUST SMOKE

NOTE:

1. Check that air cleaner is not clogged.
2. Check with customer whether oil consumption has been excessive.

(Possible Cause)

1. IMPROPER INJECTION
TIMING

(Check Procedure and Correction Method)

Refer to item 7 of ENGINE CRANKS NORMALLY BUT WILL NOT START.

NOTE: Black smoke indicates advanced timing while white smoke indicates retarded timing. Adjustments should be made accordingly.

2. CLOGGED FUEL FILTER

Refer to item 5 of LACK OF POWER.

NOTE: At high rpm (2,000 – 3,000), a clogged filter tends to make the exhaust smoke white.

3. FAULTY NOZZLE OR
NOZZLE HOLDER

Refer to item 9 of ENGINE CRANKS NORMALLY BUT WILL NOT START.

NOTE: Excessive exhaust smoke is often caused by nozzle pressure being too low.

EXCESSIVE FUEL CONSUMPTION

NOTE: Check whether clutch slipping, brakes grabbing, tires wrong size or air filter clogged.

(Possible Cause)

(Check Procedure and Correction Method)

1. FUEL LEAKAGE

Refer to item 3 of ROUGH IDLE WITH WARM ENGINE.

2. IDLE RPM TOO HIGH

After sufficiently warming up engine, check that idle rpm is as specified below.

Idle rpm: 700 M/T (ex. LX)
800 M/T (LX) & A/T

If not, adjust with idle speed adjusting screw.

3. NO-LOAD MAXIMUM RPM
TOO HIGH

Start engine, depress accelerator pedal to floor and check that no-load maximum rpm is within standard.

No-load maximum rpm:

L, 2L (ex. LS Hong Kong & Singapore, Australia
LY & LN56) & 2L-T 4,900

2L (LS Hong Kong & Singapore, Australia
LY & LN56) 4,500

If not, adjust with maximum speed adjusting screw.

4. IMPROPER INJECTION
TIMING

Refer to item 7 of ENGINE CRANKS NORMALLY BUT WILL NOT START.

5. FAULTY NOZZLE OR
NOZZLE HOLDER

Refer to item 9 of ENGINE CRANKS NORMALLY BUT WILL NOT START.

ENGINE NOISE WHEN WARM

(Clanking Noise with Excessive Vibration)

(Possible Cause)

(Check Procedure and Correction Method)

1. COOLANT TEMPERATURE
TOO LOW

Check coolant temperature with coolant temperature gauge.
If not sufficiently warm, thermostat is faulty and should be replaced.

2. IMPROPER INJECTION
TIMING

Refer to item 7 of ENGINE CRANKS NORMALLY
BUT WILL NOT START.

3. FAULTY NOZZLE OR
NOZZLE HOLDER

Refer to item 9 of ENGINE CRANKS NORMALLY
BUT WILL NOT START.

ENGINE WILL NOT RETURN TO IDLE

NOTE (ex. w/ACSD): Check that idle adjusting knob is returned.

(Possible Cause)

BINDING ACCELERATOR
LINKAGE

(Check Procedure and Correction Method)

Operate adjusting lever on top of injection pump and check if engine returns to idle. If so, accelerator cable is binding or maladjusted and should be repaired accordingly. If engine does not return to idle, injection pump is faulty and should be replaced.

ENGINE WILL NOT SHUT OFF WITH KEY

(Possible Cause)

IMPROPER FUEL CUT
SOLENOID OPERATION

(Check Procedure and Correction Method)

Disconnect connector on top of fuel cut solenoid and check if engine stops. If so, starter switch is faulty and should be repaired as necessary or replaced. If engine does not stop, either fuel cut solenoid is faulty or there is interference by foreign particles. Repair as necessary.

DIESEL ELECTRICAL SYSTEM DIAGNOSIS

ENGINE DOES NOT START COLD

- NOTE:**
1. Battery voltage at least 12 volts — starter switch OFF.
 2. Engine cranks normally.
 3. Fusible link okay.

1. Super Glow System

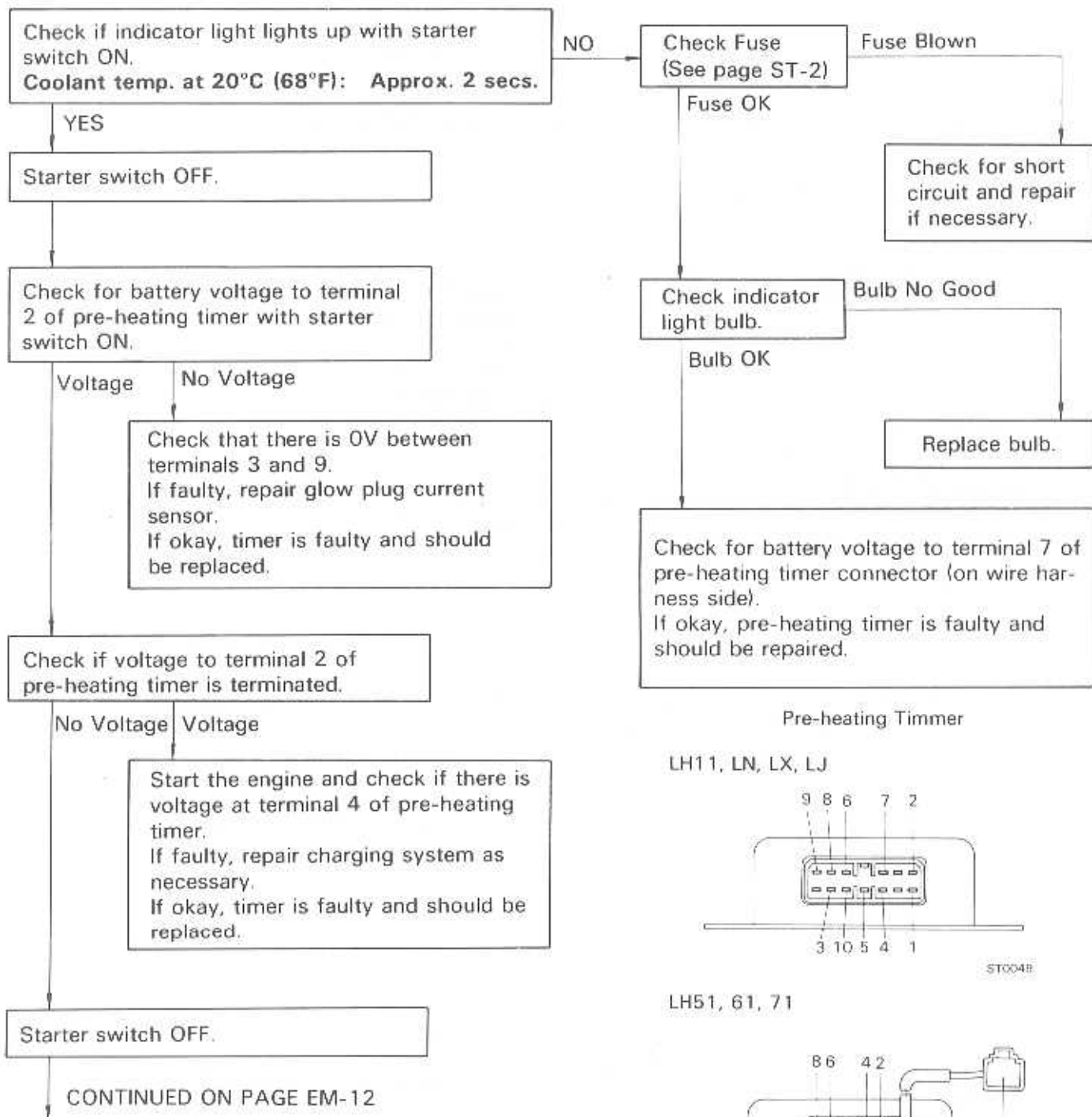

CONTINUED FROM PAGE EM-11

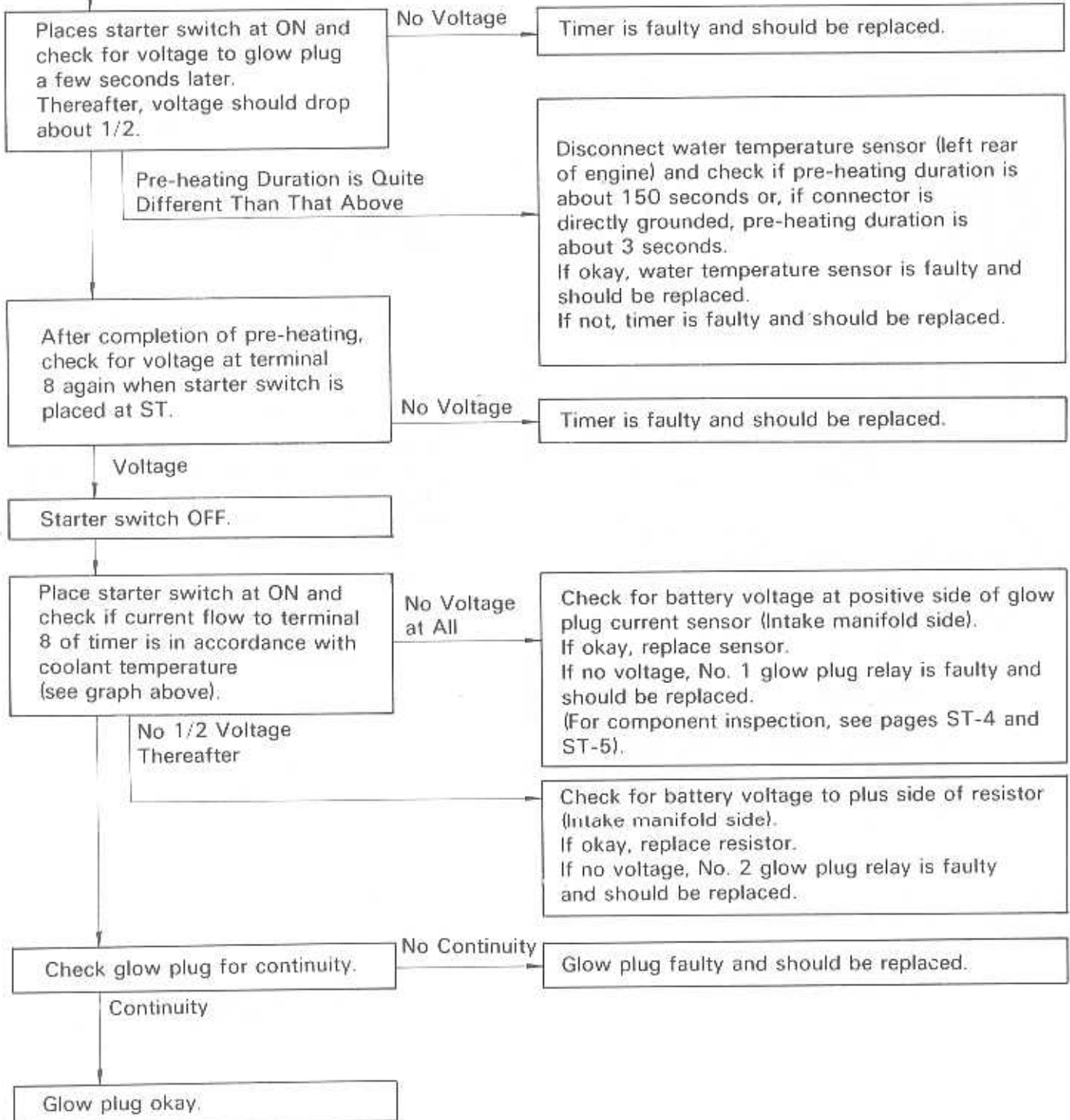
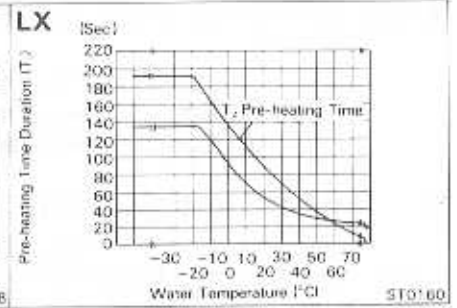
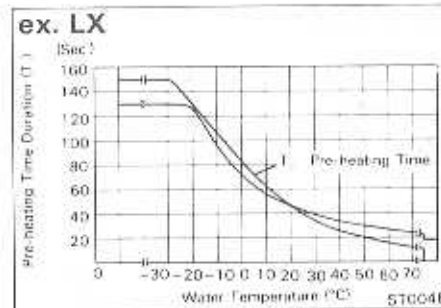

2. Fuel Cut Solenoid

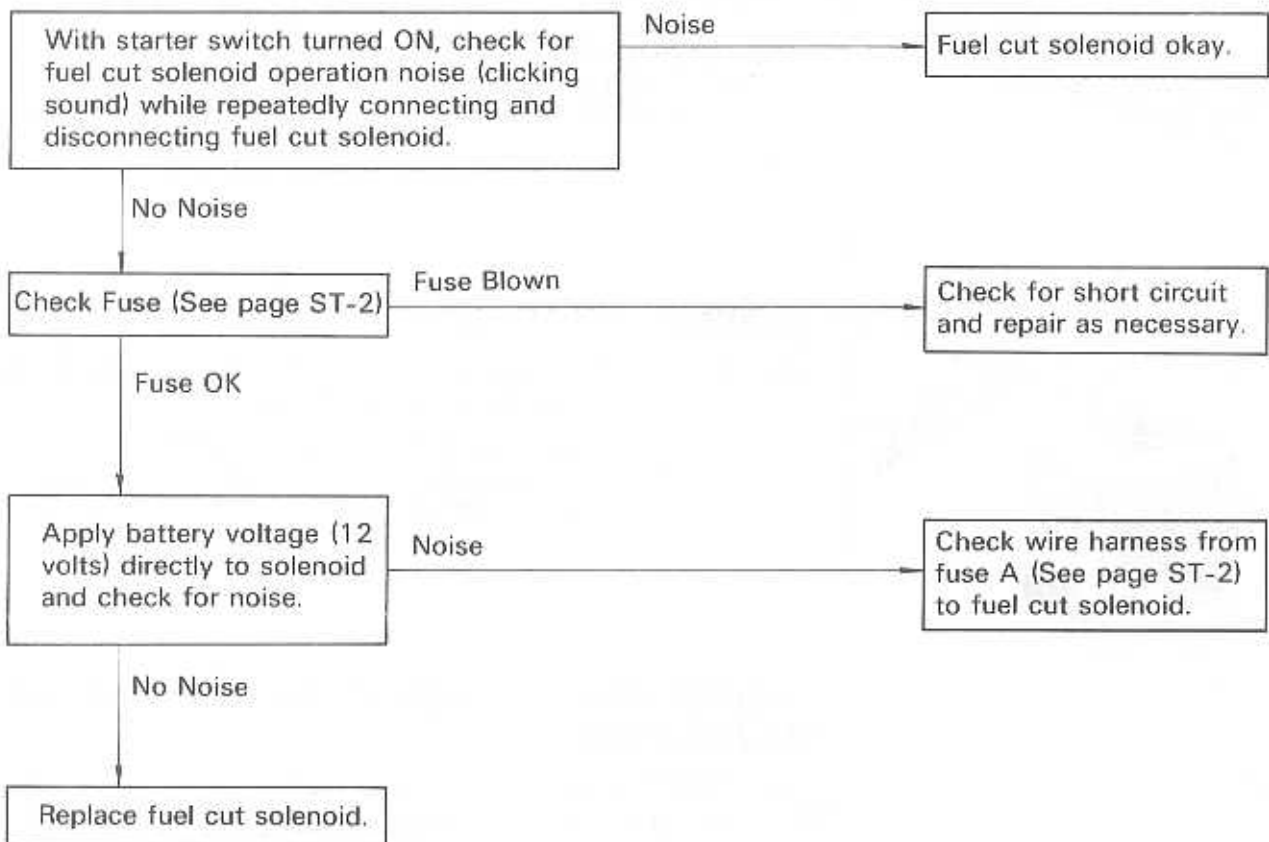

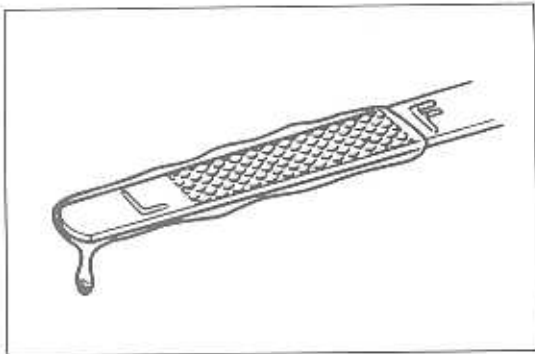

ENGINE TUNE-UP

INSPECT OIL LEVEL

The oil level should be between the "L" and "F" marks on the level gauge.

If low, check for leakage and add oil up to the "F" mark.

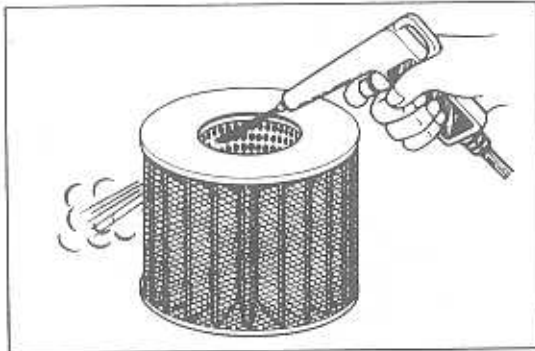

INSPECT AIR FILTER

- (a) Visually check that the air cleaner element is not excessively dirty, damaged or oily.
- (b) Clean the element with compressed air. First blow from the inside thoroughly. Then blow off the outside of the element.

INSPECTION AND ADJUSTMENT OF VALVE CLEARANCES

NOTE: Inspect and adjust the valve clearance after engine has reached normal operating temperature.

1. REMOVE CYLINDER HEAD COVER (See page EM-32)

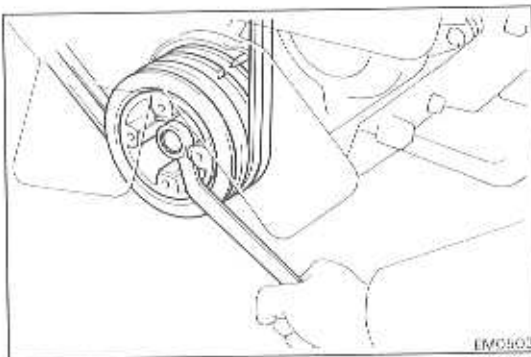

2. SET NO. 1 CYLINDER TO TDC/COMPRESSION

- (a) Set the No. 1 cylinder to TDC/compression. Align the groove on the pulley with the timing pointer by turning the crankshaft clockwise with a wrench.
- (b) Check that the rocker arms on the No. 1 cylinder are loose and rocker arms on the No. 4 cylinder are tight.

If not, turn the crankshaft one revolution (360°) and align the mark as above.

3. INSPECT AND ADJUST VALVE CLEARANCE

- (a) Measure only those valves indicated by arrows.

Valve clearance (Hot):

Intake	0.25 mm (0.0098 in.)
Exhaust	0.36 mm (0.0142 in.)

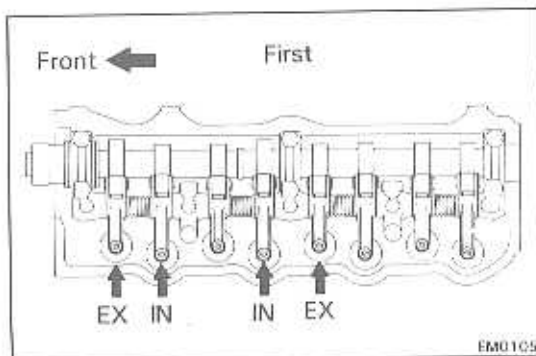

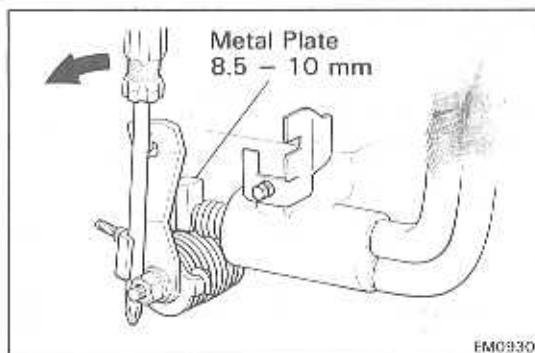
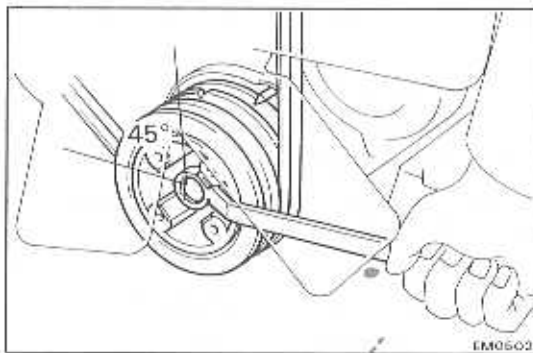
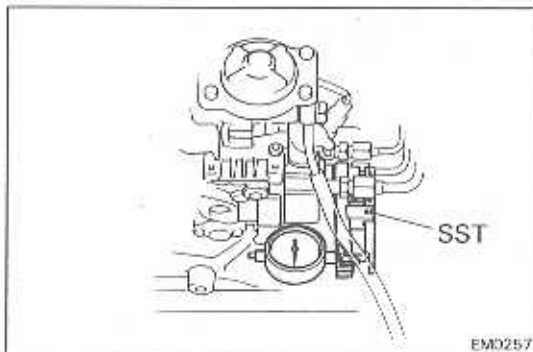
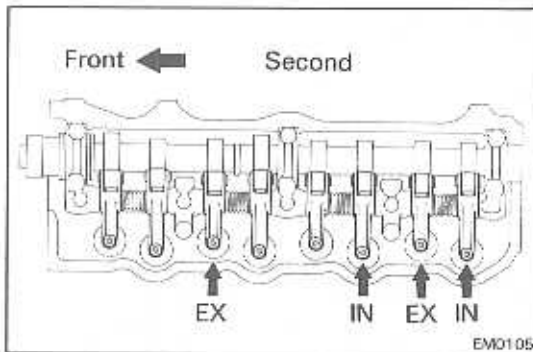
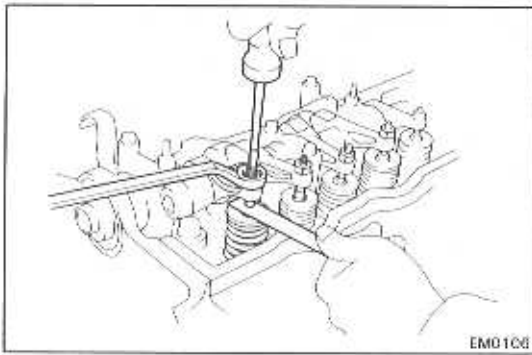

- Using a feeler gauge, measure the valve clearance between the valve stem and rocker arm. Loosen the lock nut and turn the adjusting screw to set the proper clearance. Hold the adjusting screw in position and tighten the lock nut.
- Recheck the valve clearance. The feeler gauge should slide with a very slight drag.

- (b) Turn the crankshaft one revolution (360°) and align the timing marks as above. Adjust only the valves indicated by arrows.

4. INSTALL CYLINDER HEAD COVER (See page EM-49)

INSPECTION AND ADJUSTMENT OF INJECTION TIMING

1. INSTALL PLUNGER STROKE MEASURING TOOL (SST) AND DIAL INDICATOR

- (a) Remove the distributive head bolt.
- (b) Install SST and the dial indicator to the distributive head plug hole.

SST 09275-54010

2. SET NO. 1 OR NO. 4 CYLINDER TO 45° BTDC/COMPRESSION

3. RELEASE COLD STARTING SYSTEM

- (a) Using a screwdriver, turn the cold starting lever counterclockwise about 20° as shown.
- (b) Put a metal plate 8.5 – 10 mm (0.335 – 0.394 in.) thick between the cold starting lever and thermo wax plunger.

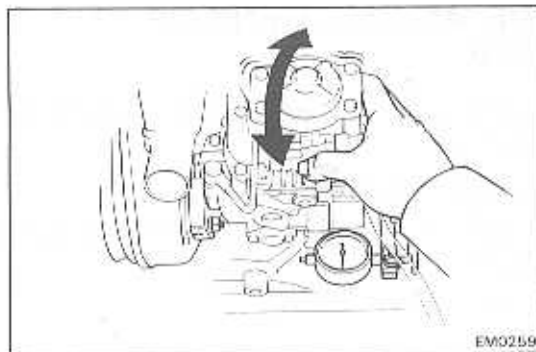
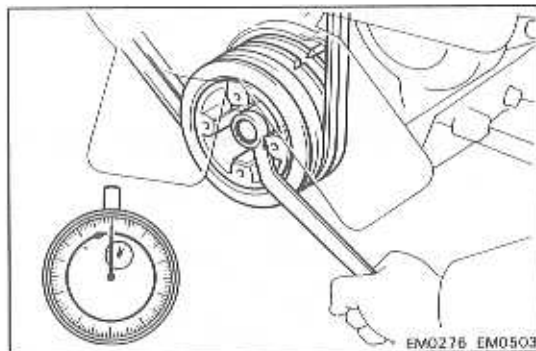
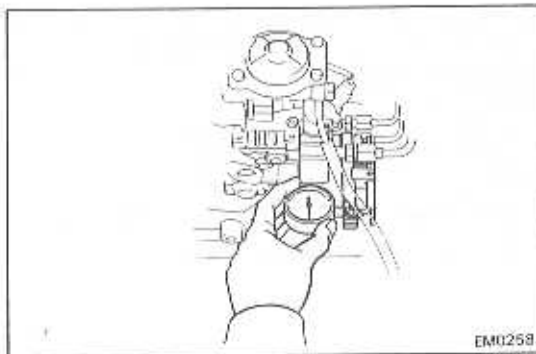

4. INSPECT AND ADJUST INJECTION TIMING

- (a) Set the dial gauge at zero mm (0 in.).
- (b) Recheck to see that the dial gauge remains at zero mm (0 in.), while rotating the crankshaft pulley slightly to the left and right.
- (c) Slowly rotate the crankshaft pulley until No. 1 or No. 4 cylinder is at TDC/compression.
- (d) Measure the plunger stroke.

Plunger stroke:

L	0.94 – 1.06 mm (0.0370 – 0.0417 in.)
2L	w/o ACSD 1.06 – 1.22 mm (0.0417 – 0.0480 in.)
	w/ ACSD 0.82 – 0.98 mm (0.0323 – 0.0386 in.)
2L-T	0.75 – 0.87 mm (0.0295 – 0.0343 in.)

- (e) Loosen the four injection pipe union nuts and fuel inlet pipe union nut at the injection pump side.
- (f) Loosen the four injection pump mounting bolts and two nuts.
- (g) Adjust the plunger stroke by slightly tilting the injection pump body.

If the stroke is less than specification, tilt the pump toward engine.

If greater than specification, tilt the pump away from engine.

- (h) Tighten the injection pump mounting bolts and nuts.

Torque:

Bolts	185 kg-cm (13 ft-lb, 18 N·m)
Nuts	210 kg-cm (15 ft-lb, 21 N·m)

- (i) Recheck the plunger stroke.
- (j) Tighten the injection pipe union nuts and fuel inlet pipe union nut.

Torque:

Injection pipe	250 kg-cm (18 ft-lb, 25 N·m)
Inlet pipe	230 kg-cm (17 ft-lb, 23 N·m)

5. REMOVE METAL PLATE FROM COLD STARTING LEVER

6. REMOVE SST AND DIAL INDICATOR

- (a) Remove SST and the dial indicator.
- SST 09275-54010
- (b) Install the distribution head bolt with a new gasket. Torque the bolts.

Torque: 170 kg-cm (12 ft-lb, 17 N·m)

7. START ENGINE AND CHECK FOR LEAKS

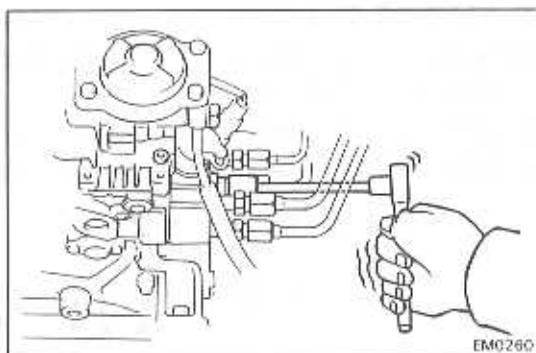

INSPECTION AND ADJUSTMENT OF IDLE AND MAXIMUM SPEEDS

1. INITIAL CONDITIONS:

- (a) Air cleaner installed
- (b) Engine coolant normal operating temperature
- (c) Accessories switched off
- (d) Transmission in neutral

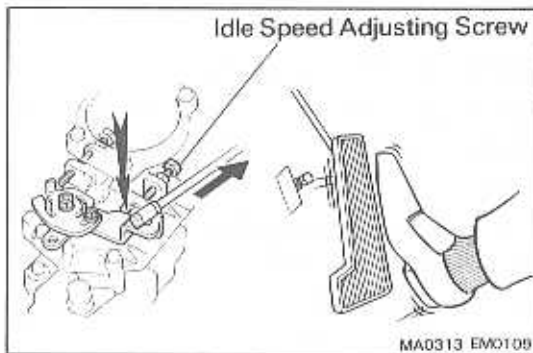

2. INSPECT AND ADJUST IDLE SPEED

- (a) Check that the adjusting lever touches the idle speed adjusting screw when the accelerator pedal is released.

If not, adjust the accelerator linkage.

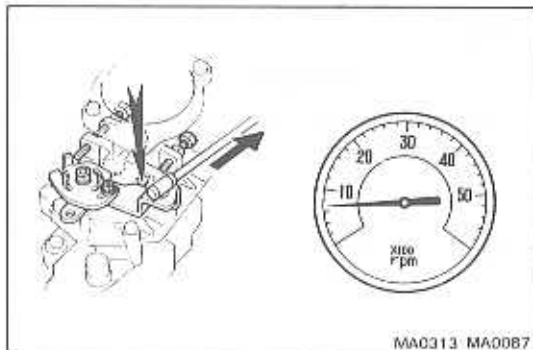

- (b) Install a tachometer to the engine.

- (c) Start the engine.

- (d) Check the idle speed.

Idle speed: 700 rpm M/T (ex. LX)
800 rpm M/T (LX) & A/T

- (e) Adjust the idle speed.

- Disconnect the accelerator linkage.
- Loosen the lock nut of the idle speed adjusting screw.
- Adjust the idle speed by turning the IDLE SPEED ADJUSTING SCREW.
- Securely tighten the lock nut.
- Connect the accelerator linkage.
- After adjustment, adjust the accelerator linkage.

3. INSPECT AND ADJUST MAXIMUM SPEED

- (a) Check that the adjusting lever touches the maximum speed adjusting screw when the accelerator pedal is depressed all the way.

If not, adjust the stop bolt of the accelerator pedal.

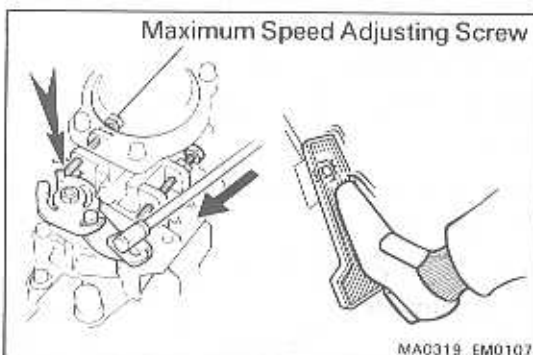

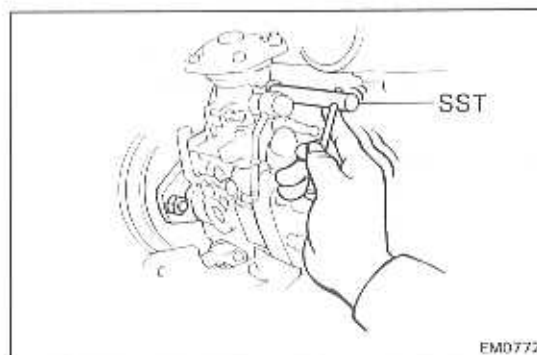
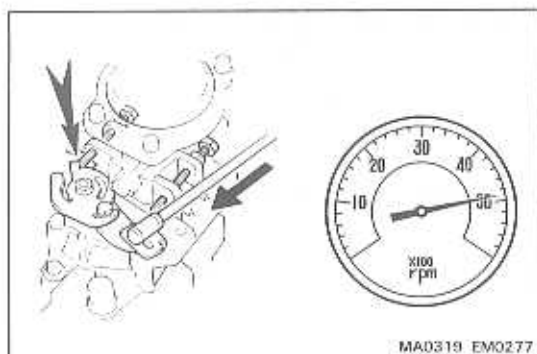

- (b) Install a tachometer to the engine.
- (c) Start the engine.
- (d) Depress the accelerator pedal all the way.
- (e) Check the maximum speed.

Maximum speed:

L, 2L (ex. LS Hong Kong & Singapore, Australia LY & LN56) & 2L-T	4,900 rpm
2L (LS Hong Kong & Singapore, Australia LY & LN56)	4,500 rpm

- (f) Adjust the maximum speed.
 - Disconnect the accelerator linkage.
 - Using SST, loosen the lock nut of the maximum speed adjusting screw.

SST 09275-54020

- Adjust the maximum speed by the **MAXIMUM SPEED ADJUSTING SCREW**.

NOTE: Adjust at idle speed. Then, raise engine speed and recheck the maximum speed.

- Using SST, securely tighten the lock nut.

SST 09275-54020

- Connect the accelerator linkage.
- After adjustment, adjust the stop bolt of the accelerator pedal.

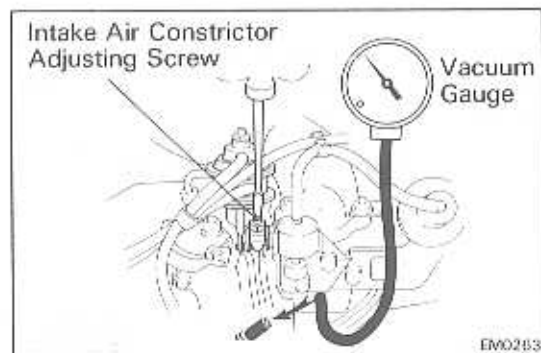
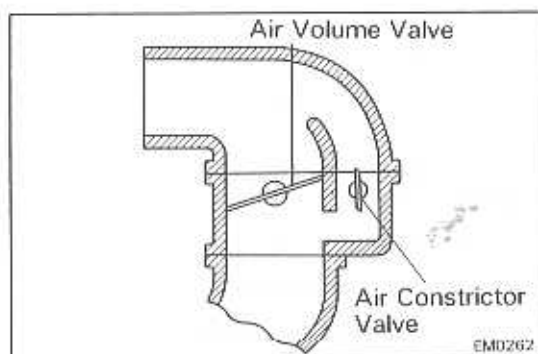
**CHECK AND ADJUSTMENT OF INTAKE AIR VOLUME (LS, LX71 M/T)****1. INITIAL CONDITIONS:**

- (a) Air cleaner installed
- (b) Engine coolant normal operating temperature.
- (c) Accessories switched off
- (d) Transmission in neutral
- (e) 900 meters or less above sea level.
- (f) Intake air volume valve fully closed.

2. CHECK AND ADJUST INTAKE AIR VOLUME

- (a) Install a vacuum gauge to the intake manifold.
- (b) Start the engine.
- (c) Check the intake manifold vacuum.

Vacuum: 110 – 150 mmHg
(4.33 – 5.91 in.Hg, 14.7 – 20.0 kPa)

- (d) Adjust the vacuum by loosening the lock nut and turning the **INTAKE AIR CONSTRICTOR ADJUSTING SCREW**.

COMPRESSION CHECK

NOTE: If there is lack of power, excessive oil or fuel consumption, measure the cylinder compression pressure.

1. **WARM UP ENGINE**
2. **DISCONNECT FUEL CUT SOLENOID WIRE CONNECTOR**
3. **REMOVE FOUR GLOW PLUGS**
(See page EM-21)

CAUTION: Make sure the load wire is not grounded.

4. **INSTALL SST TO GLOW PLUG MOUNTING HOLE**
SST 09992-00023

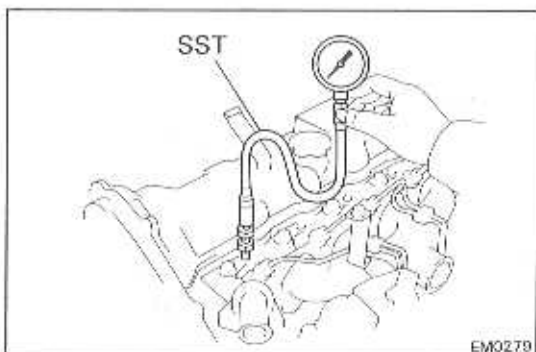
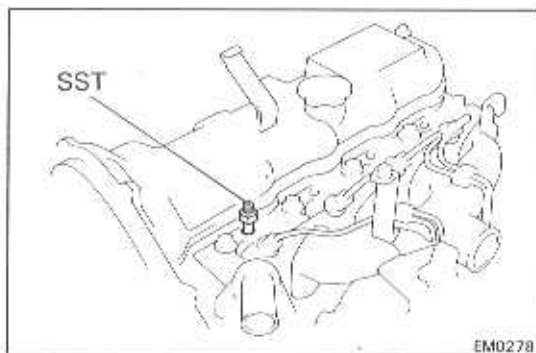

5. **MEASURE CYLINDER COMPRESSION PRESSURE**

(a) Connect a compression gauge (SST) to SST.
SST 09992-00023

(b) While cranking the engine with the starter, measure the compression pressure.

NOTE: Always use a fully charged battery so that at least 250 rpm can be reached.

(c) Repeat steps (a) and (b) for each cylinder.

Compression pressure:

→ L, 2L-T 30.0 kg/cm² (427 psi, 2,942 kPa) ← *
2L 32.0 kg/cm² (455 psi, 3,138 kPa)

Minimum pressure

20.0 kg/cm² (284 psi, 1,961 kPa)

Difference between each cylinder:

Less than 5.0 kg/cm² (71 psi, 490 kPa)

- (d) If the cylinder compression in one or more cylinders is low, pour a small amount of engine oil into the cylinder through the glow plug hole and repeat steps (a) and (b) for the cylinder with low compression.
 - If adding oil helps the compression, chances are that the piston rings and/or cylinder bore are worn or damaged.
 - If pressure stays low, a valve may be sticking or seating improperly, or there may be leakage past the gasket.

TIMING BELT

NOTE: If replacing the timing belt before the timing belt warning light comes on, (light comes on after 100, 000 km of driving), be sure to reset the timing belt counter of the speedometer to zero.

COMPONENTS

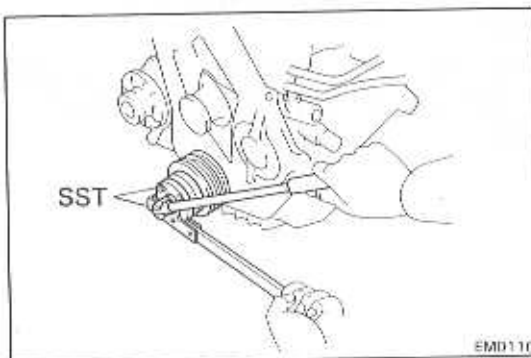
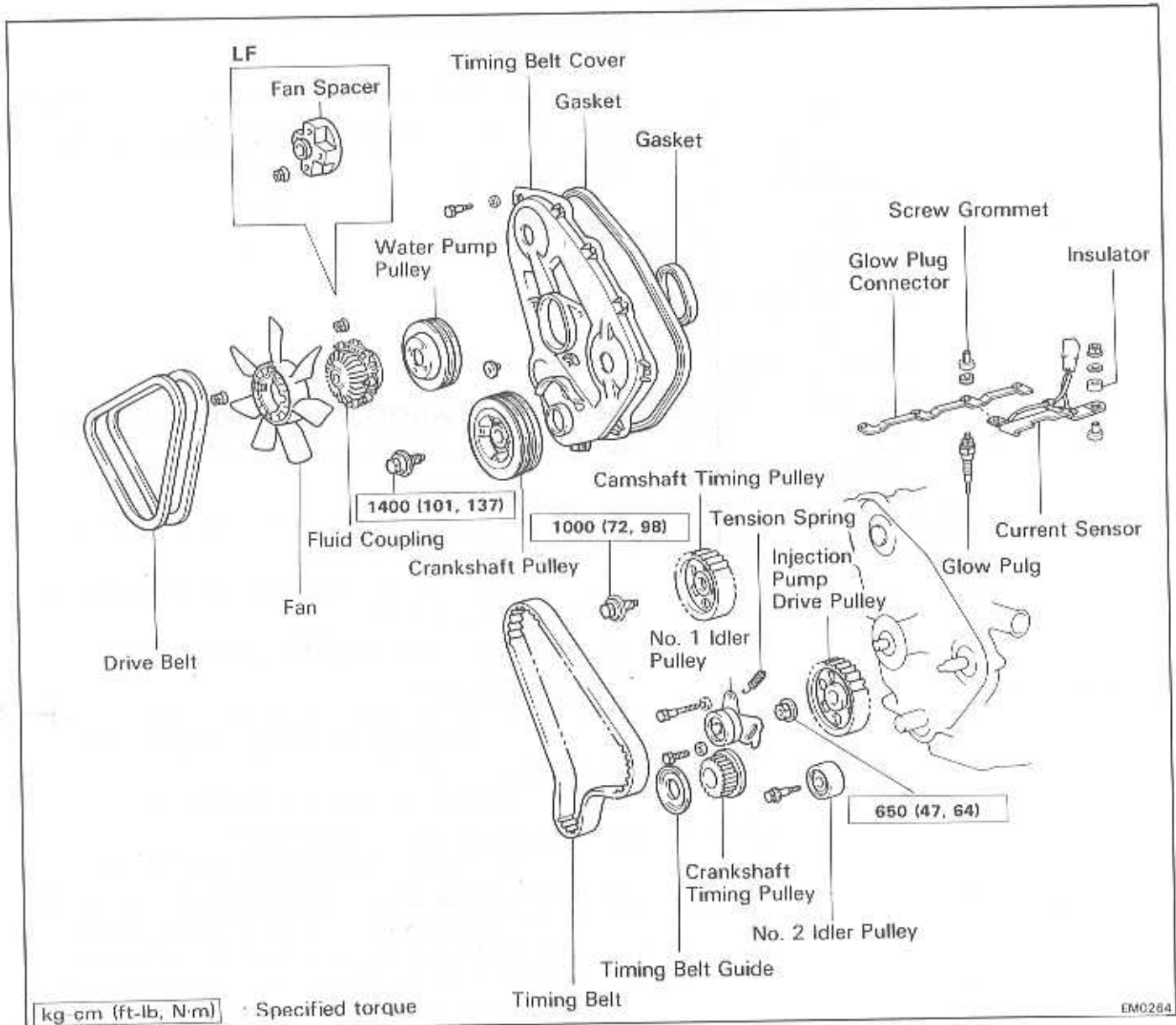

REMOVAL OF TIMING BELT

1. REMOVE DRIVE BELTS
2. REMOVE WATER PUMP PULLEY
(See step 3 on pages CO-4)
3. REMOVE CRANKSHAFT PULLEY
 - (a) Using SST, remove the mount bolt.
SST 09213-54012 and 09330-00020

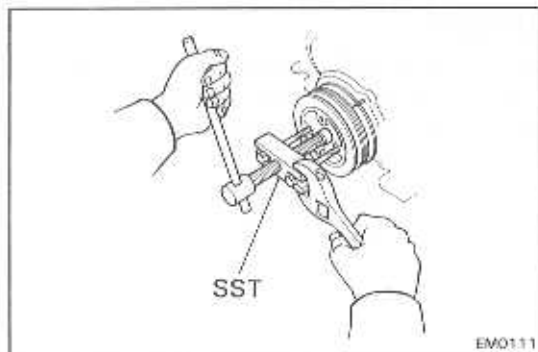

- (b) Using SST, remove the pulley.
SST 09213-60017

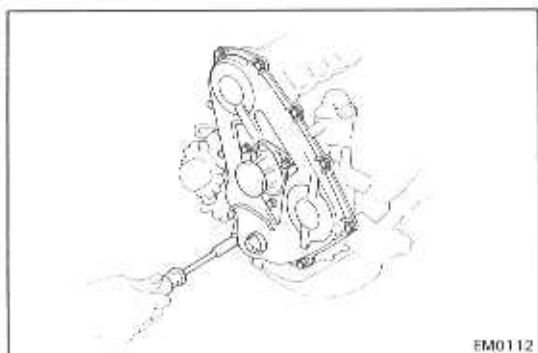

4. REMOVE TIMING BELT COVER

Remove the twelve bolts and belt cover with the two gaskets.

5. REMOVE TIMING BELT GUIDE

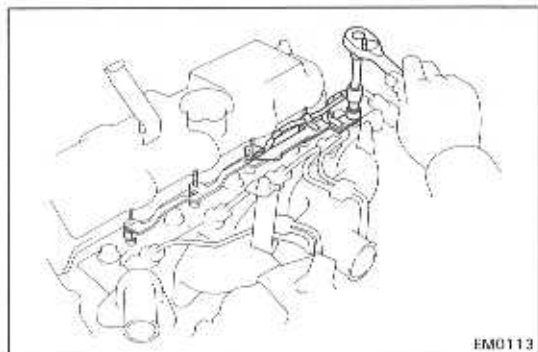

6. REMOVE CURRENT SENSOR AND FOUR GLOW PLUGS

- (a) Remove the four screw grommets.
(b) Remove the four glow plug connecting nuts.
(c) **[Europe (LH, LX, LN)]**
Remove the nut, plate washer, insulators and current sensor.
(d) Remove the glow plug connector.

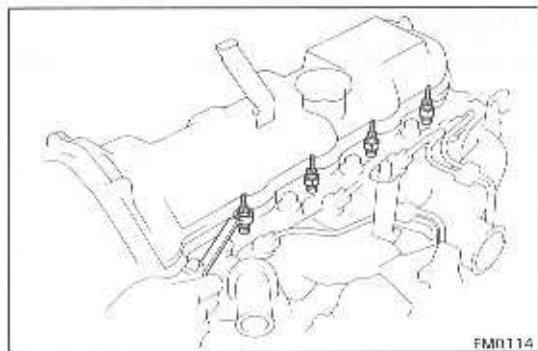

- (e) Remove the four glow plugs.

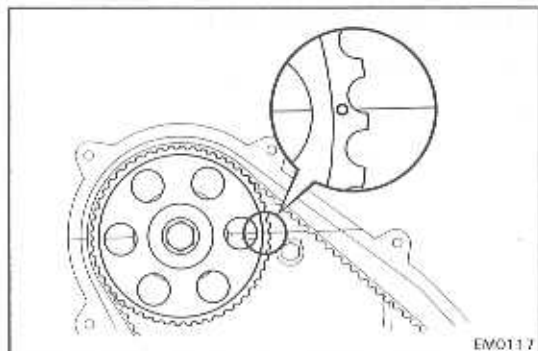

7. SET NO. 1 CYLINDER TO TDC/COMPRESSION

Using a crankshaft pulley mount bolt, align the TDC mark of the camshaft timing pulley with the top end of the cylinder head.

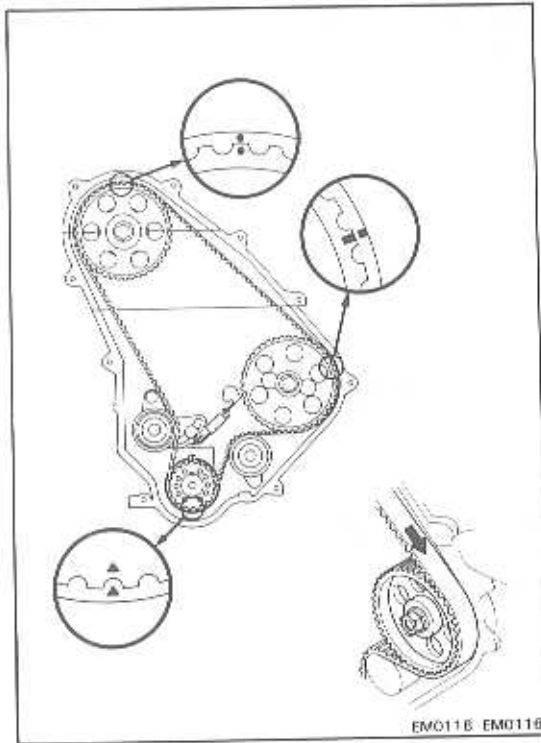

8. REMOVE TIMING BELT

NOTE: If reusing the timing belt, draw a direction arrow on the belt (in direction of engine revolution), and place matchmarks on the pulleys and timing belt.

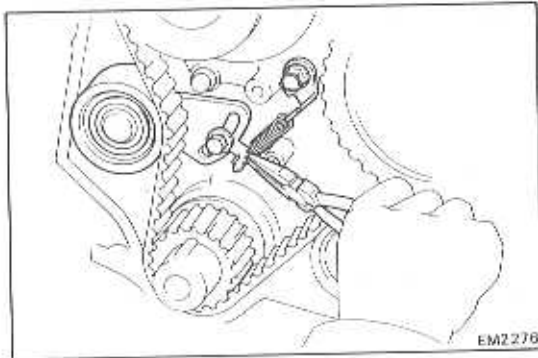

- (a) Using needle-nosed pliers, remove the tension spring.
- (b) Loosen the two No. 1 idler pulley mount bolts.
- (c) Remove the timing belt.

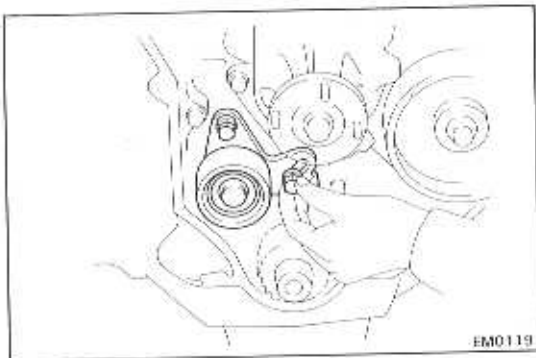

9. REMOVE NO. 1 IDLER PULLEY

Remove the two mount bolts, plate washers and idler pulley.

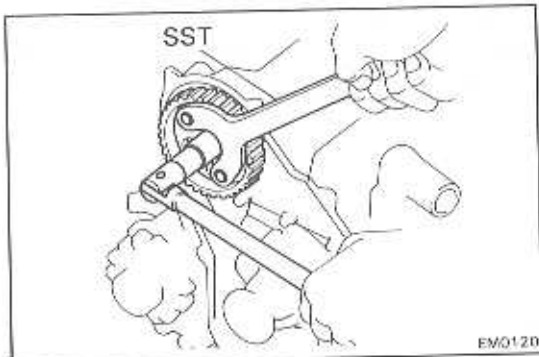

10. REMOVE CAMSHAFT TIMING PULLEY

Using SST, remove the mount bolt.
SST 09278-54011

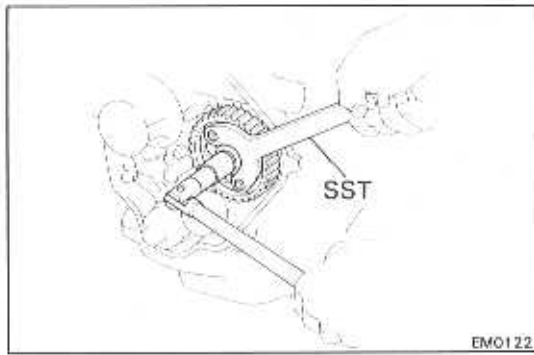
**11. REMOVE INJECTION PUMP DRIVE PULLEY**

- (a) Using SST, remove the mount nut.
SST 09278-54011

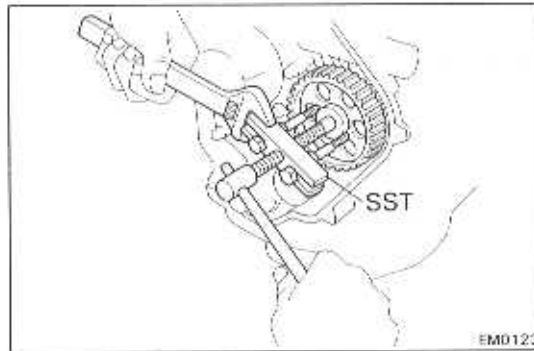

- (b) Using SST, remove the pump drive pulley.
SST 09213-60017

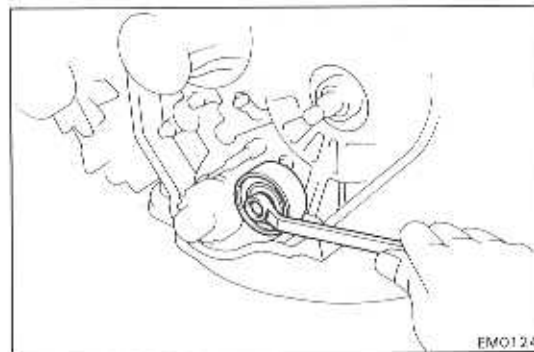
**12. REMOVE NO. 2 IDLER PULLEY**

- Remove the mount bolt and No. 2 idler pulley.

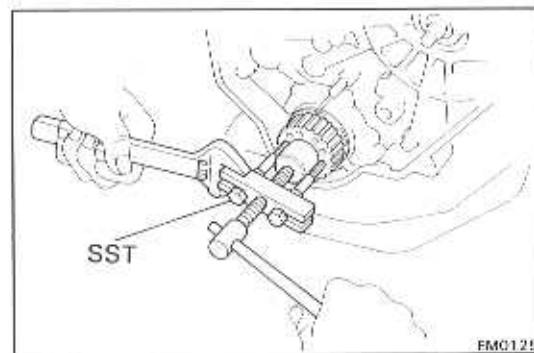
**13. REMOVE CRANKSHAFT TIMING PULLEY**

- Using SST, remove the crankshaft timing pulley.
SST 09213-60017

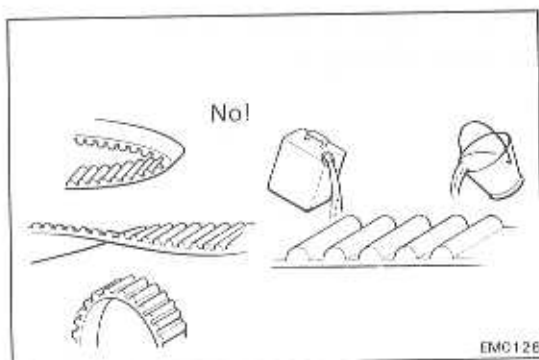

INSPECTION OF COMPONENTS

1. INSPECT TIMING BELT

CAUTION:

1. Do not bend, twist or turn the belt inside out.
2. Do not allow the belt to come into contact with oil, water or steam.
3. Do not utilize belt tension when installing or removing the set bolt of the camshaft timing pulley.

If there are defects as shown in the figures, check the following points and replace the timing belt if necessary.

(a) Premature parting

- Check for proper installation.
- Check the timing cover gasket for damage, and check for correct installation.

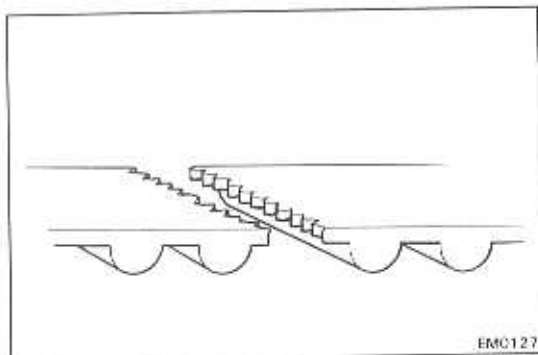

(b) If the belt teeth are cracked or damaged, check to see if the camshaft, water pump or oil pump is locked.

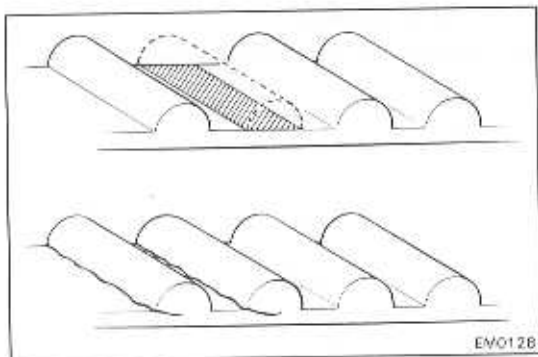

(c) If there is noticeable wear or cracks on the belt face, check to see if there are nicks on one side of the idler pulley lock.

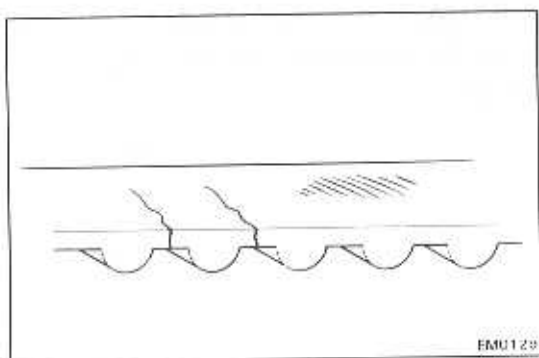

(d) If there is wear or damage on only one side of the belt, check the belt guide and the alignment of each pulley.

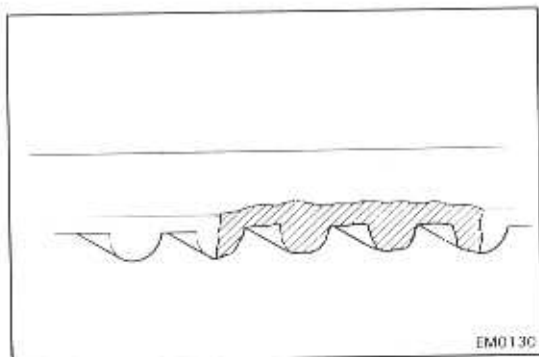

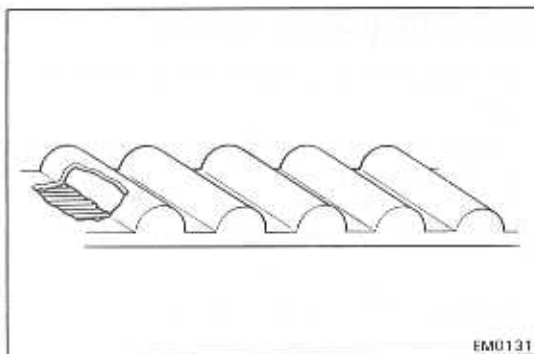

- (e) If there is noticeable wear on the belt teeth, check the timing cover gasket for damage and check for correct gasket installation. Check for foreign materials on the pulley teeth.

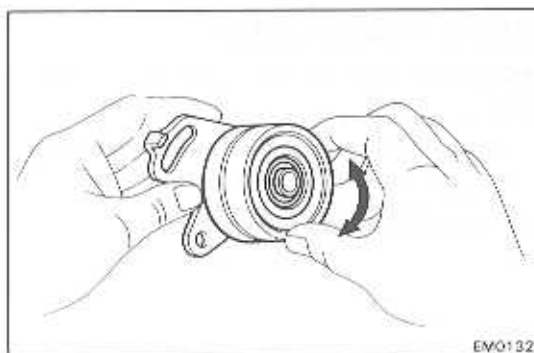

2. INSPECT IDLER PULLEYS

Check the turning smoothness of the timing belt idler pulleys.

If necessary, replace the idler pulley.

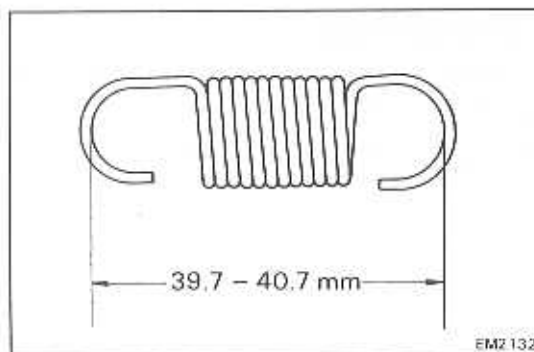

3. INSPECT TENSION SPRING

- (a) Check the free length of the spring.

Free length:

39.7 - 40.7 mm (1.563 - 1.602 in.)

- (b) Check the tension of the spring at the specified installed length.

Installed tension:

4.0 kg (8.8 lb, 39 N) at 52 mm (2.05 in.)

If not specified, replace the spring.

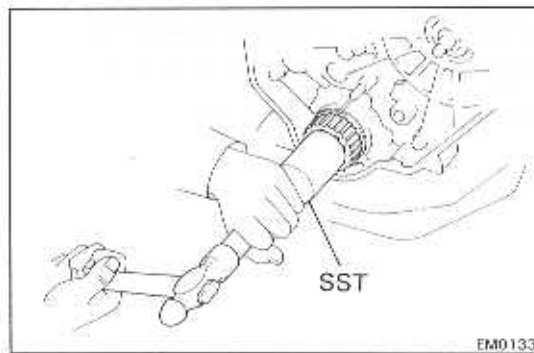

INSTALLATION OF TIMING BELT

(See page EM-20)

1. INSTALL CRANKSHAFT TIMING PULLEY

- (a) Align the timing pulley set key with the key groove of the timing pulley.

- (b) Using SST and a hammer, drive in timing pulley.

SST 09214-60010

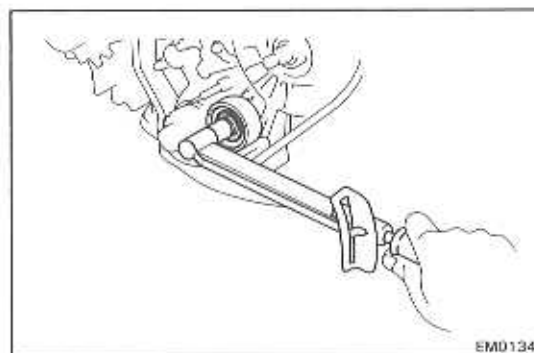

2. INSTALL NO. 2 IDLER PULLEY

Torque: 400 kg-cm (29 ft-lb, 39 N·m)

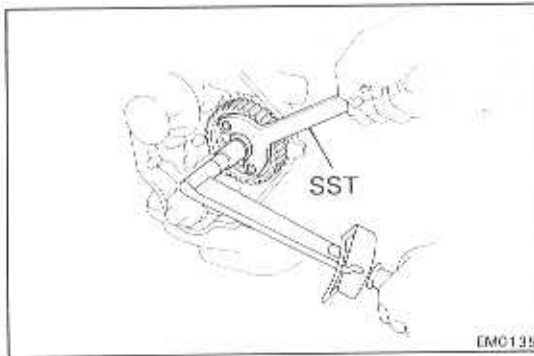

3. INSTALL INJECTION PUMP DRIVE PULLEY

- Align the drive pulley set key with the key groove of the drive pulley.
- Using SST, install the drive pulley with the mount nut. Torque the mount nut.

Torque: 650 kg-cm (47 ft-lb, 64 N·m)

SST 09278-54011

CAUTION: Do not use an impact wrench.

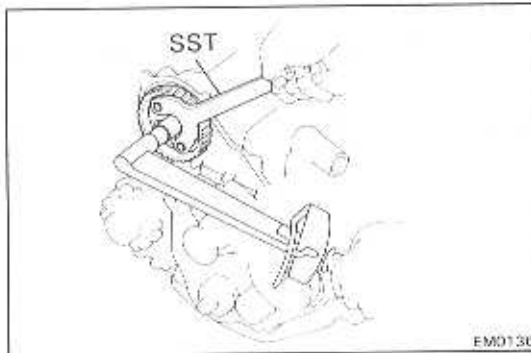

4. INSTALL CAMSHAFT TIMING PULLEY

- Align the timing pulley knock pin with the pin hole of the timing pulley.
- Using SST, install the timing pulley with the mount bolt and plate washer. Torque the mount bolt.

Torque: 1,000 kg-cm (72 ft-lb, 98 N·m)

SST 09278-54011

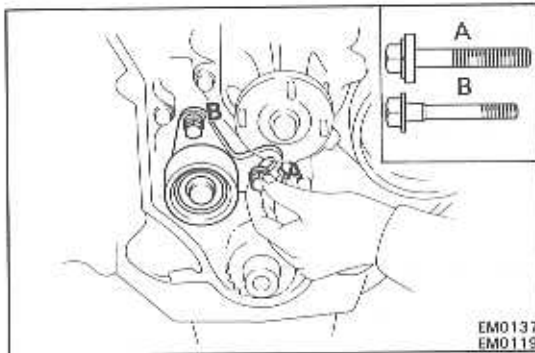

5. INSTALL NO. 1 IDLER PULLEY

- Temporarily install the idler pulley with the two mount bolts and plate washers.
- Swing the idler pulley toward the left.

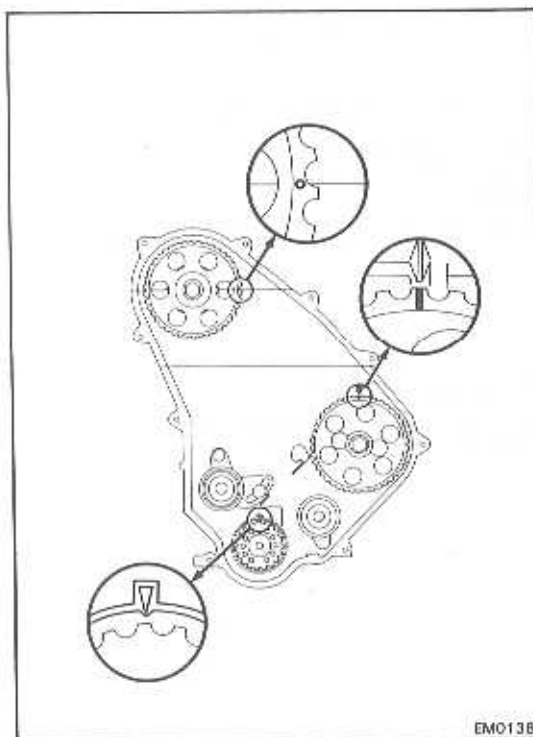

6. SET NO. 1 CYLINDER TO TDC/COMPRESSION

Align the timing and drive pulleys at each position.

CAUTION: The engine should be cold.

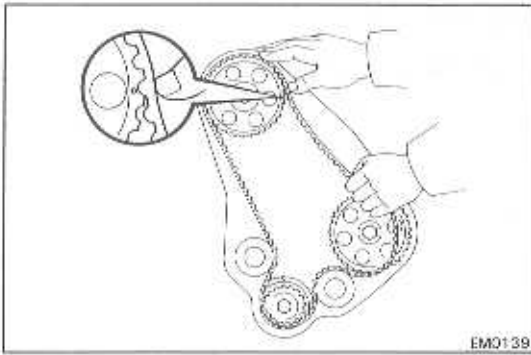

7. INSTALL TIMING BELT

If using new timing belt:

- (a) Install the timing belt to the camshaft timing pulley.
CAUTION: Be sure the timing belt is securely meshed and not loose.

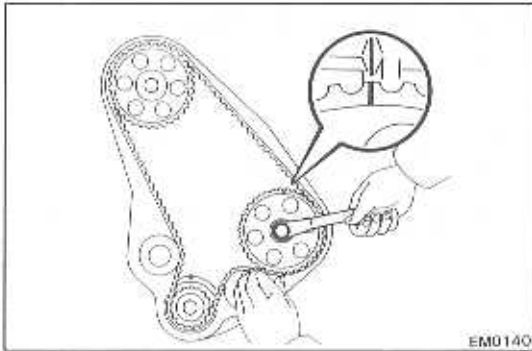

- (b) Align the timing marks of the pump drive pulley and oil pump body.

- (c) Install the timing belt to the pump drive pulley.

CAUTION: Be sure the timing belt is securely meshed and not loose.

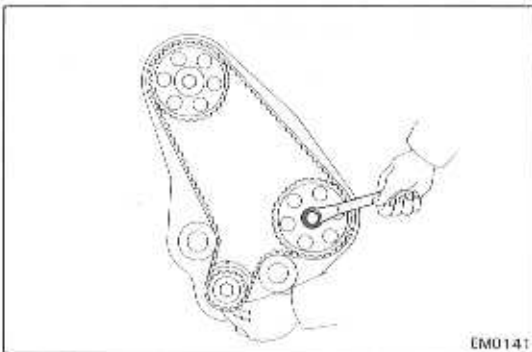

- (d) Install the timing belt to the No. 2 idler pulley and crankshaft timing pulley.

CAUTION: Be sure the belt is not twisted or too tight.

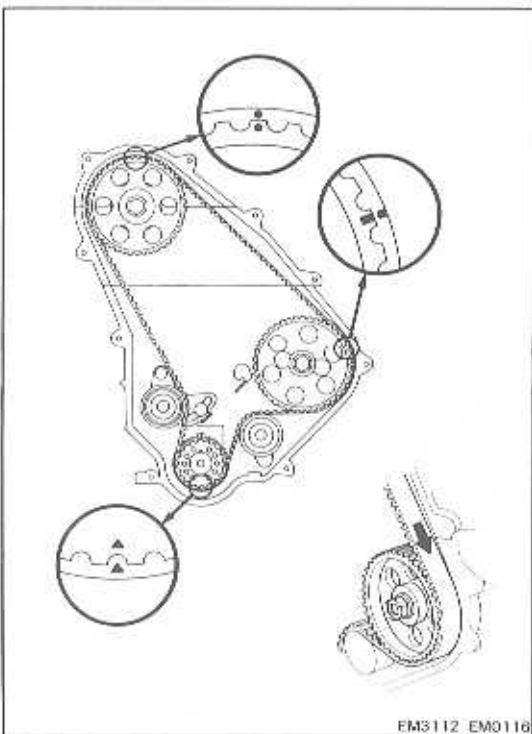

If reusing timing belt:

Align the points marked during removal and install the timing belt with the arrow pointing in the direction of engine revolution.

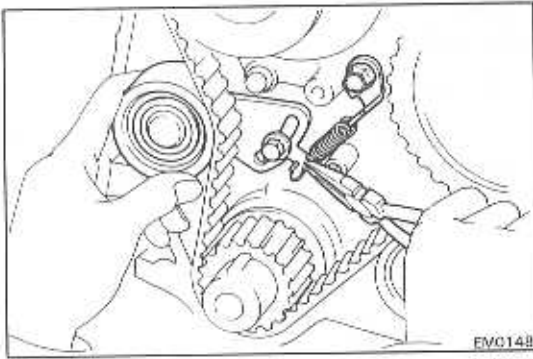

8. INSTALL TENSION SPRING

CAUTION: Loosen the mount bolts to where the timing belt idle pulley lightly moves with tension spring force.

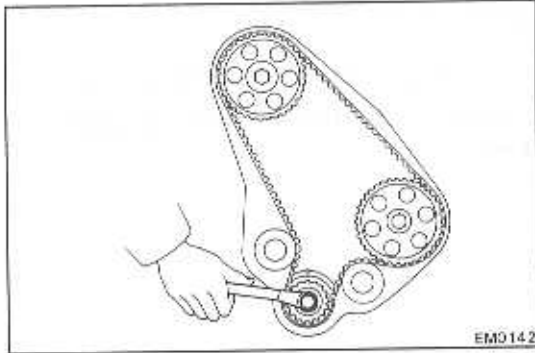

9. CHECK POSITION OF TIMING AND DRIVE PULLEYS

- (a) Place a crankshaft pulley mount bolt on the crankshaft.
- (b) Using a wrench, turn the crankshaft pulley mount bolt 2 revolutions from TDC to TDC.

CAUTION: Always turn the crankshaft clockwise.

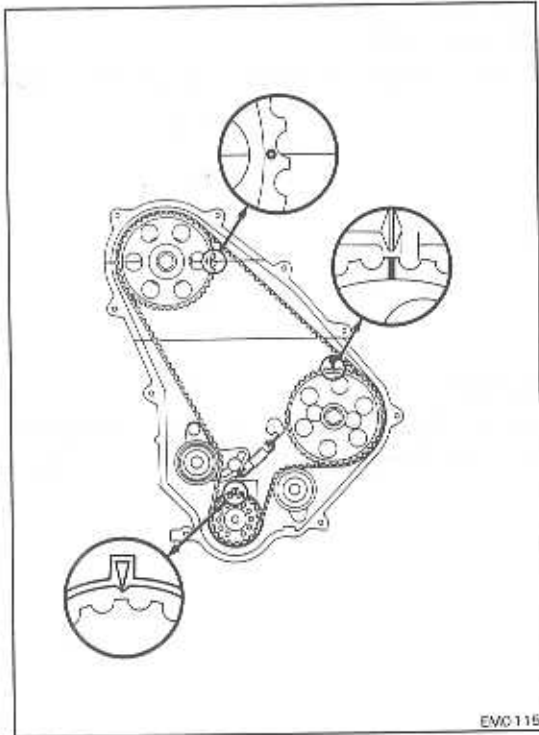

- (c) Check that each pulley aligns with the marks.

If the marks do not align, remove the timing belt and reinstall it.

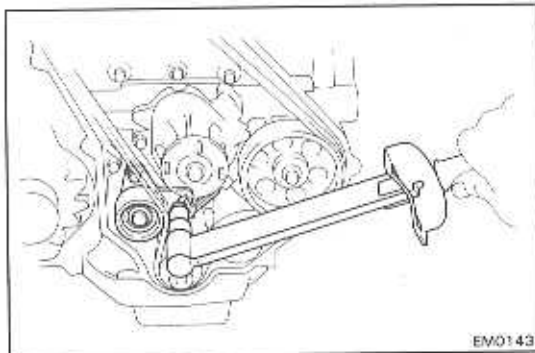

10. TORQUE NO. 1 IDLER PULLEY MOUNT BOLTS

Torque: 195 kg-cm (14 ft-lb, 19 N·m)

CAUTION: While tightening the mount bolts, do not move the idler pulley bracket.

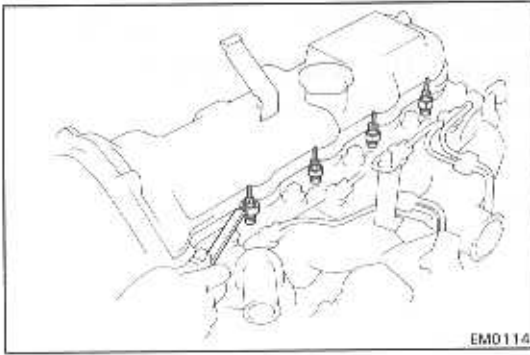

11. INSTALL FOUR GLOW PLUGS AND CURRENT SENSOR

(a) Install and torque the four glow plugs.

Torque: 130 kg-cm (9 ft-lb, 13 N·m)

(b) Place the glow plug connector on the glow plugs.

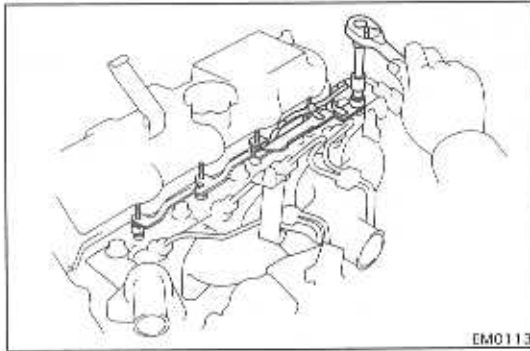

(c) **[Europe (LH, LX, LN)]**

Install the current sensor with the insulators, plate washer and nut.

(d) Install the four glow plug connecting nuts.

(e) Install the four screw grommets.

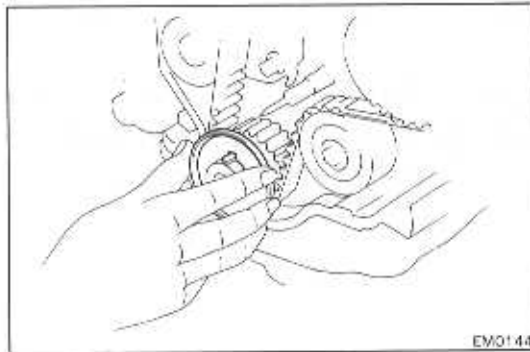

12. INSTALL TIMING BELT GUIDE

Align the set key on the crankshaft with the key groove of the belt guide and slide it in.

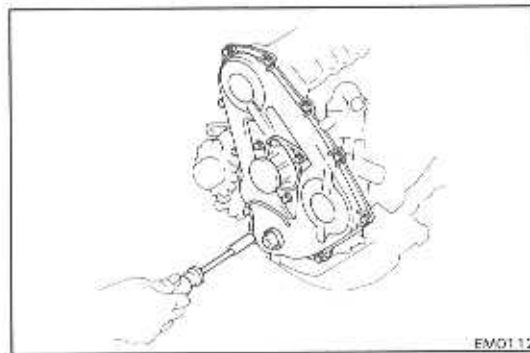

13. INSTALL TIMING BELT COVER

(a) Install the gaskets to the belt cover.

(b) Install the belt cover with the twelve bolts.

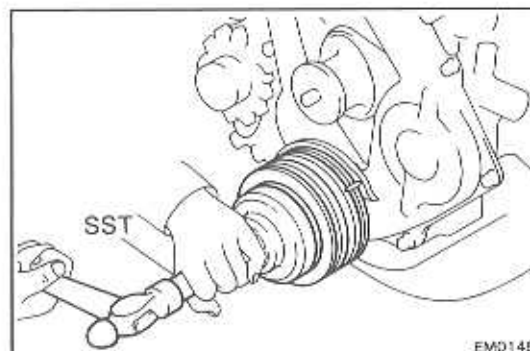

14. INSTALL CRANKSHAFT PULLEY

(a) Align the pulley set key with the key groove of the pulley.

(b) Using SST and a hammer, drive in the pulley.

SST 09223-63010

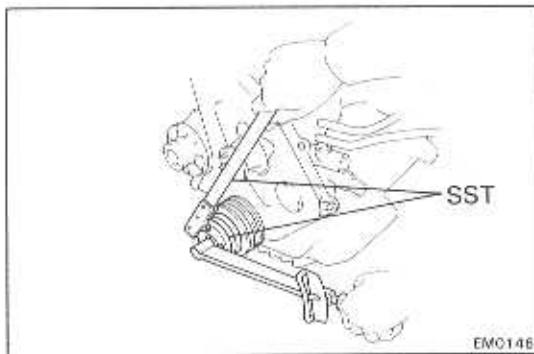

(c) Using SST, install the mount bolt and torque it.

Torque: 1,400 kg-cm (101 ft-lb, 137 N·m)

SST 09213-54012 and 09330-00020

15. INSTALL WATER PUMP PULLEY
(See step 4 on page CO-6)

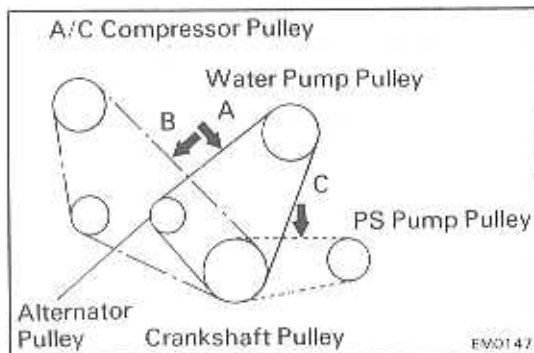

16. INSTALL DRIVE BELTS

Drive belt deflection at 10 kg (22 lb, 98 N) mm (in.)

Position	Belt condition	
	New	Used
A (Water pump- Alternator)	7 - 10 (0.28 - 0.39)	10 - 14 (0.39 - 0.55)
B (Crankshaft- A/C compressor)	13 - 17 (0.51 - 0.67)	17 - 23 (0.67 - 0.91)
C (Crankshaft- PS pump)	8 - 10 (0.31 - 0.39)	10 - 14 (0.39 - 0.55)

NOTE:

- "New belt" refers to a belt which has never been used.
- "Used belt" refers to a belt which has been used on a running engine for 5 minutes or more.

CYLINDER HEAD COMPONENTS

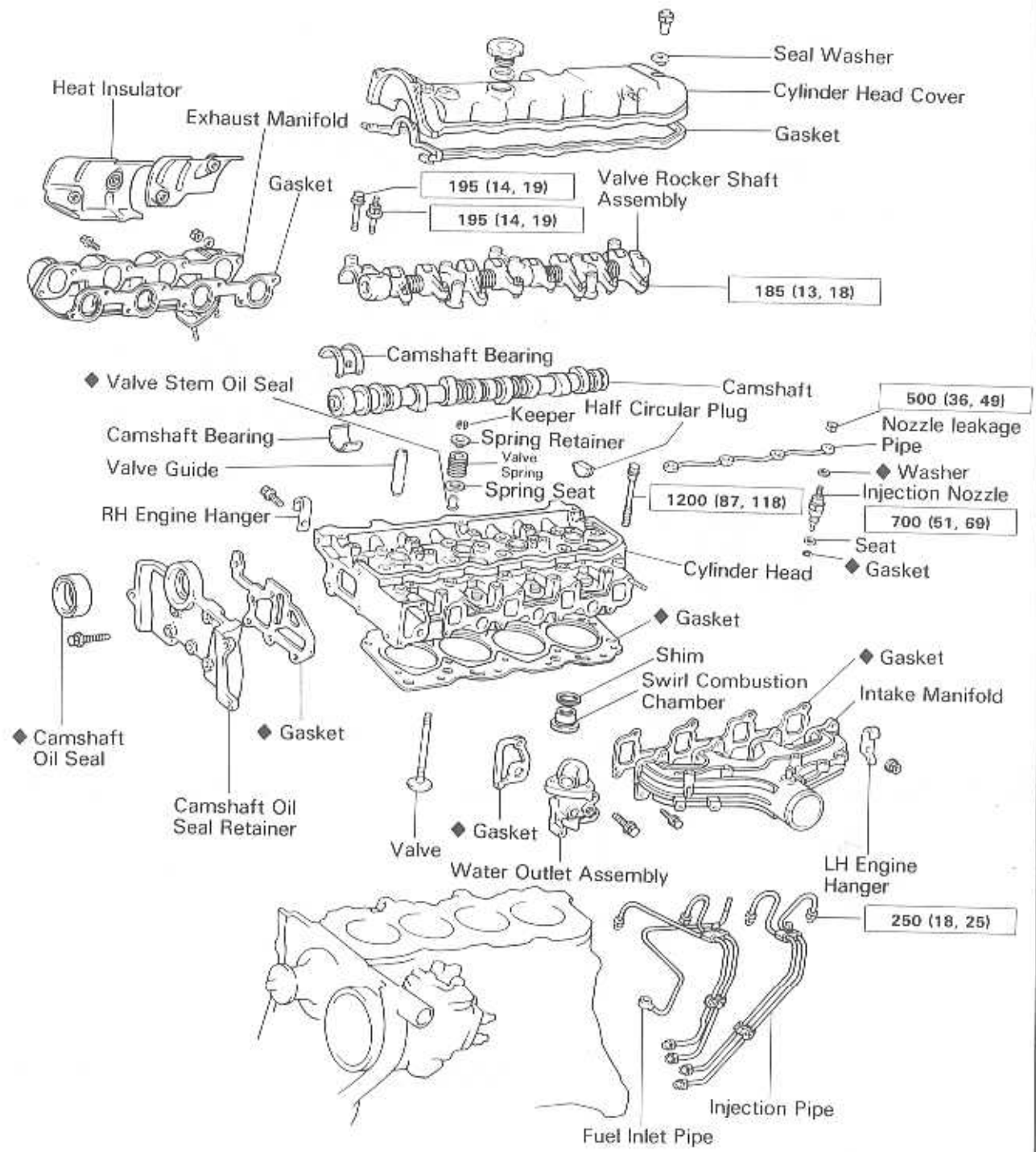

[kg-cm (ft-lb, N-m)] : Tightening torque

◆ Non-reusable part

REMOVAL OF CYLINDER HEAD

1. REMOVE FOUR INJECTION PIPES
(See step 1 on page FU-7)
2. REMOVE FOUR INJECTION NOZZLES
(See steps 2, 3 on pages FU-7, 8)
3. REMOVE FUEL INLET PIPE
(See step 10 on page FU-14)
4. REMOVE CYLINDER HEAD COVER
 - (a) Remove the two bolts holding the head cover to the belt cover.
 - (b) Remove the three cap nuts, seal washers, head cover and gasket.
5. REMOVE TIMING BELT
(See steps 1 to 8 on pages EM-20 to 22)
6. REMOVE CAMSHAFT TIMING PULLEY
(See step 10 on page EM-22)
7. DISCONNECT ACCELERATOR CONNECTING ROD FROM ACCELERATOR LINK

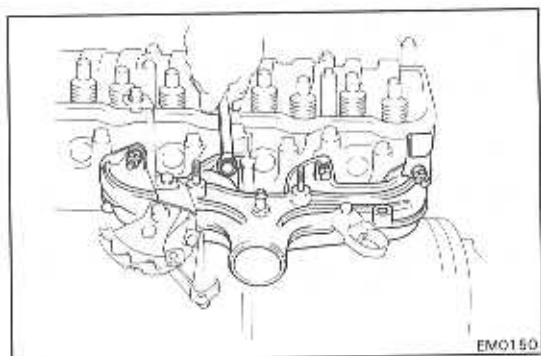
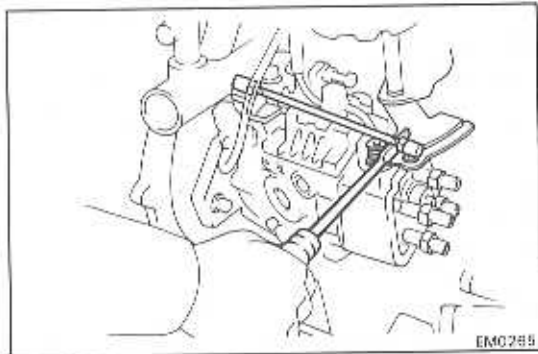
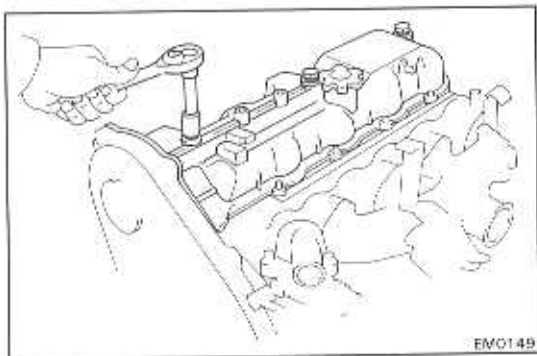

8. REMOVE INTAKE MANIFOLD AND LH ENGINE HANGER
Remove the six bolts, two nuts, LH engine hanger and intake manifold and gasket.
9. REMOVE WATER OUTLET ASSEMBLY
Remove the two bolts, water outlet assembly and gasket.

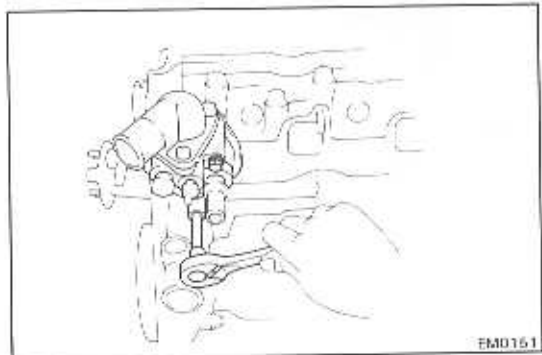

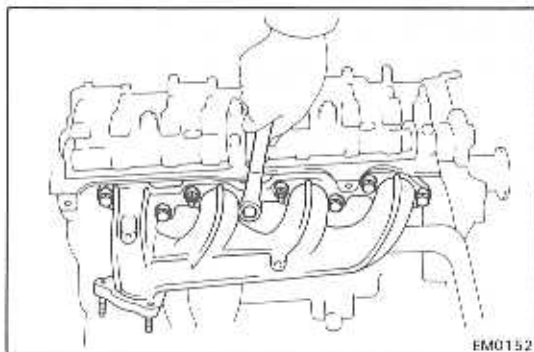
**10. REMOVE RH ENGINE HANGER****11. REMOVE EXHAUST MANIFOLD**

- (a) Remove the four bolts and two heat insulators.
- (b) Remove the six bolts, two nuts, two plate washers and exhaust manifold.

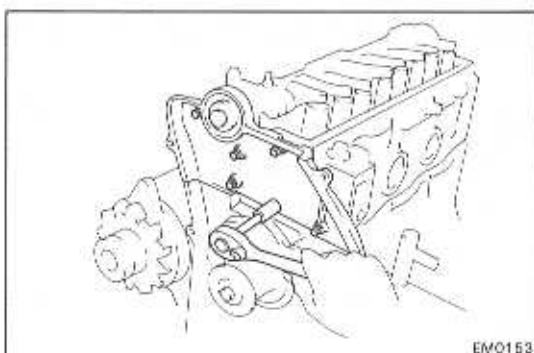
**12. REMOVE CAMSHAFT OIL SEAL RETAINER**

Remove the six bolts, retainer with oil seal and gasket.

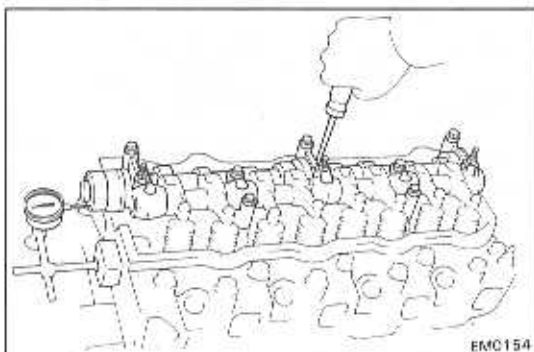
**13. CHECK CAMSHAFT THRUST CLEARANCE**

- (a) Loosen the valve clearance adjusting screws.
- (b) Using a dial indicator, measure the thrust clearance while moving the camshaft back and forth.

Standard clearance: 0.055 – 0.155 mm
(0.0022 – 0.0061 in.)

Maximum clearance: 0.3 mm (0.012 in.)

If the thrust clearance is greater than maximum, replace the camshaft and/or bearing.

14. REMOVE VALVE ROCKER SHAFT ASSEMBLY, CAMSHAFT AND BEARINGS, AND CHECK CAMSHAFT OIL CLEARANCE

- (a) Gradually loosen and remove the ten bolts in three passes and in the numerical order shown.
- (b) Remove the rocker shaft assembly and camshaft with the three upper bearings.

NOTE: Keep the upper bearing inserted with the caps.

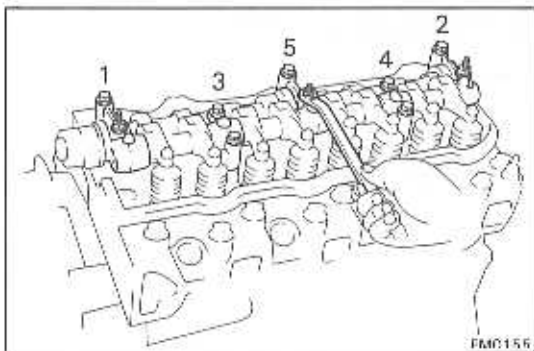

- (c) Clean each camshaft journal and bearing.
- (d) Check each camshaft journal and bearing for pitting and scratches.

If the camshaft journal and bearing are damaged, grind or replace the camshaft and replace the bearing.

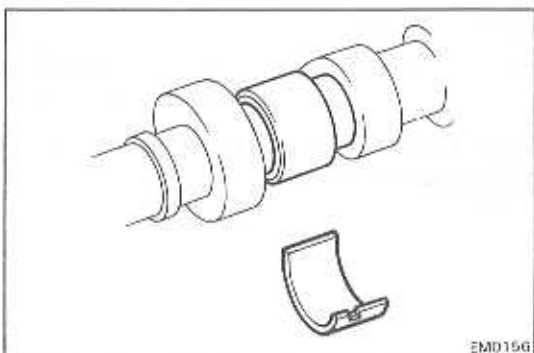

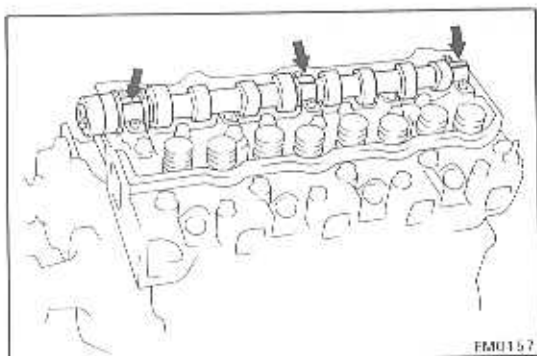

- (e) Place the camshaft on the cylinder head.
- (f) Lay a strip of Plastigage across each journal.

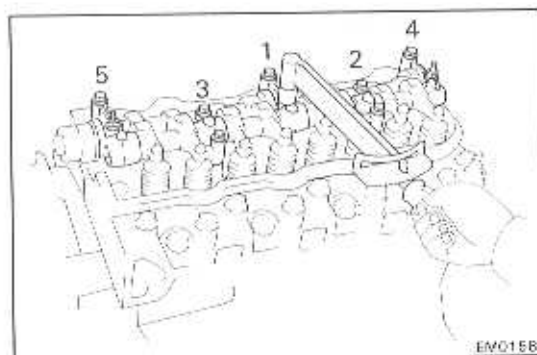

- (g) Install the valve rocker shaft assembly on the cylinder head.
- (h) Install and gradually tighten the ten bolts in three passes in the sequence shown. Torque the bolts on the final pass.

Torque: 195 kg-cm (14 ft-lb, 19 N·m)

NOTE: Do not turn the camshaft.

- (i) Remove the rocker shaft assembly with the three upper bearing.

- (j) Measure the Plastigage at its widest point.

**Standard oil clearance: 0.022 – 0.074 mm
(0.0009 – 0.0029 in.)**

Maximum oil clearance: 0.1 mm (0.004 in.)

If clearance is greater than maximum, replace the bearing. Grind the camshaft or replace the camshaft as required.

- (k) Completely remove the Plastigage.
- (l) Remove the camshaft and three lower bearings.

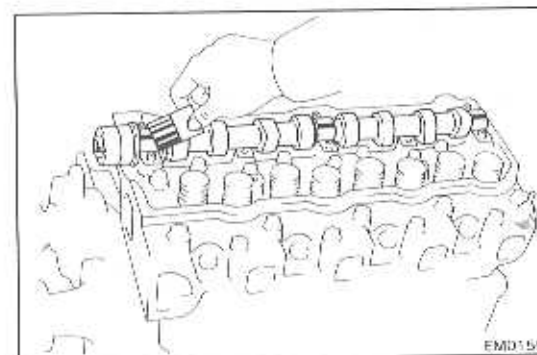

NOTE: Arrange the bearings in order.

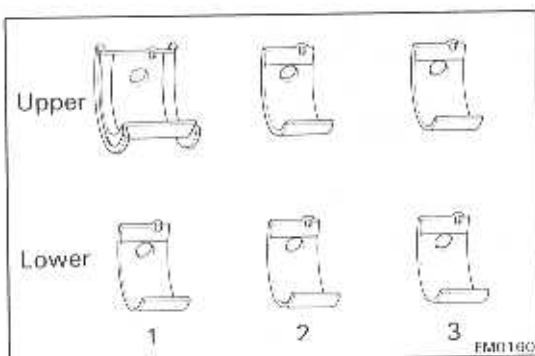

15. REMOVE HALF CIRCULAR PLUG

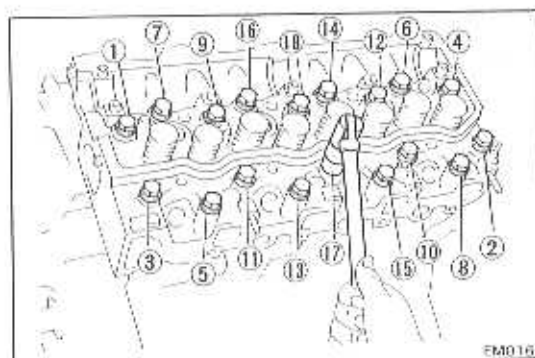

16. REMOVE CYLINDER HEAD

- (a) Gradually loosen and remove the eighteen head bolts in three passes and in the numerical order shown.

CAUTION: Head warpage or cracking could result from removing in incorrect order.

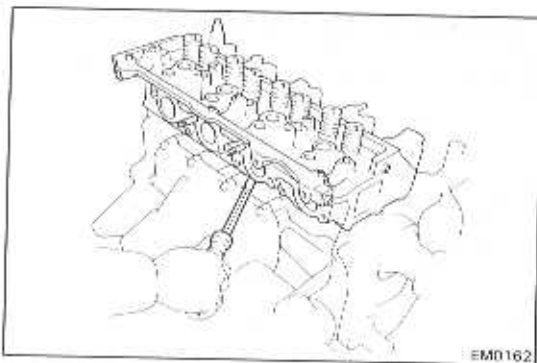

- (b) Lift the cylinder head from the dowels on the cylinder block and place the head on wooden blocks on a bench.

NOTE: If the cylinder head is difficult to lift off, pry with a screwdriver between the cylinder head and block saliences.

- (c) Remove the cylinder head gasket.

CAUTION: Be careful not to damage the cylinder head and block surface on the cylinder and head gasket sides.

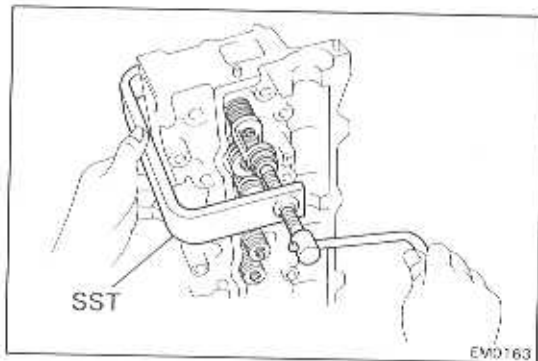

DISASSEMBLY OF CYLINDER HEAD

(See page EM-31)

1. REMOVE VALVES

- (a) Using SST, remove the keepers, spring retainer and spring.

SST 09202-43013

- (b) Remove the valve, oil seal and spring seat.

NOTE: Arrange the disassembled parts in order.

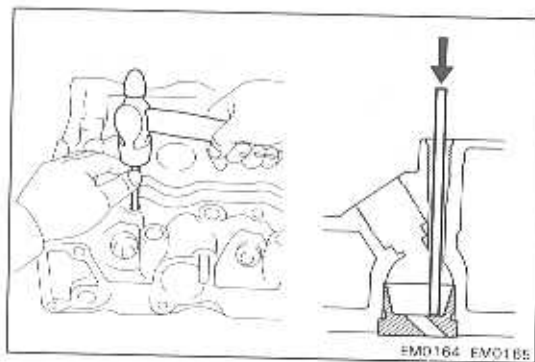
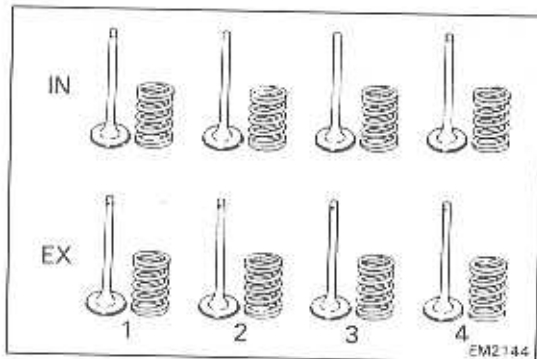

2. REMOVE COMBUSTION CHAMBERS

Drive out the combustion chambers and/or shim.

NOTE: Arrange the disassembled parts in order.

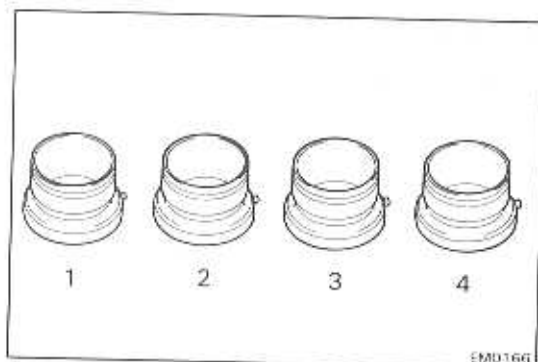

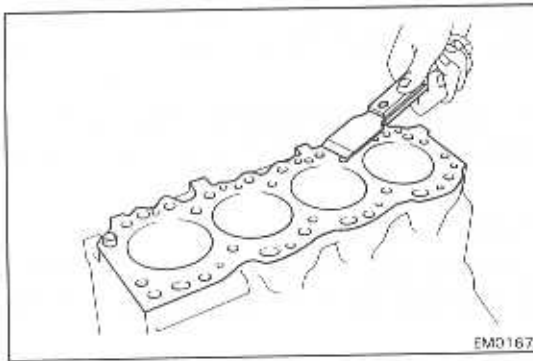

INSPECTION, CLEANING AND REPAIR OF CYLINDER HEAD COMPONENTS

1. CLEAN TOP OF PISTONS AND TOP OF BLOCK

- (a) Turn the crankshaft and bring each piston to top dead center. Scrape the carbon from the piston top.
- (b) Remove all gasket material from the top of the block. Blow carbon and oil from the bolt holes.

CAUTION: Protect your eyes when using compressed air.

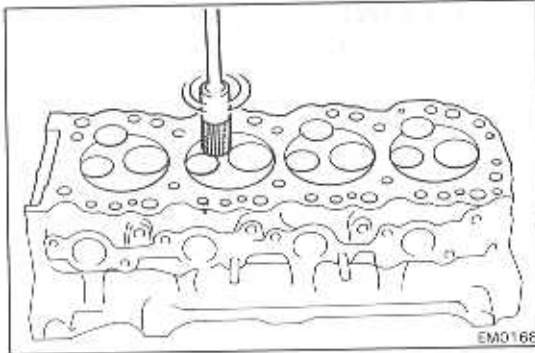

2. CLEAN COMBUSTION CHAMBER

Using a wire brush, remove all the carbon from the combustion chambers.

CAUTION: Be careful not to scratch the head gasket contact surface.

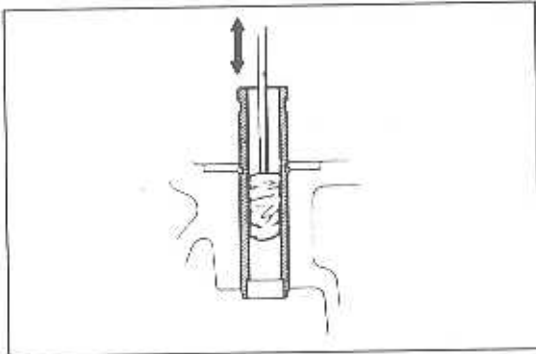

3. CLEAN VALVE GUIDES

Using a valve guide brush and solvent, clean all the valve guides.

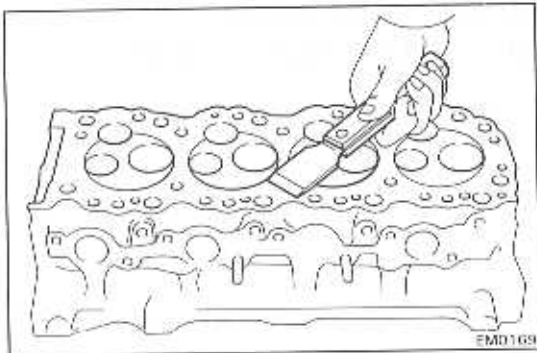

4. REMOVE GASKET MATERIAL

Using a gasket scraper, remove all gasket material from the manifold and head surface.

CAUTION: Be careful not to scratch the surfaces.

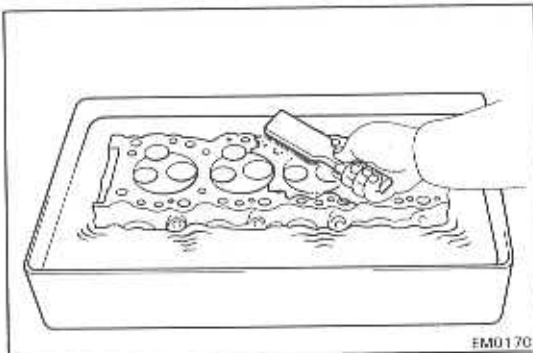

5. CLEAN CYLINDER HEAD

Using a soft brush and solvent, clean the head.

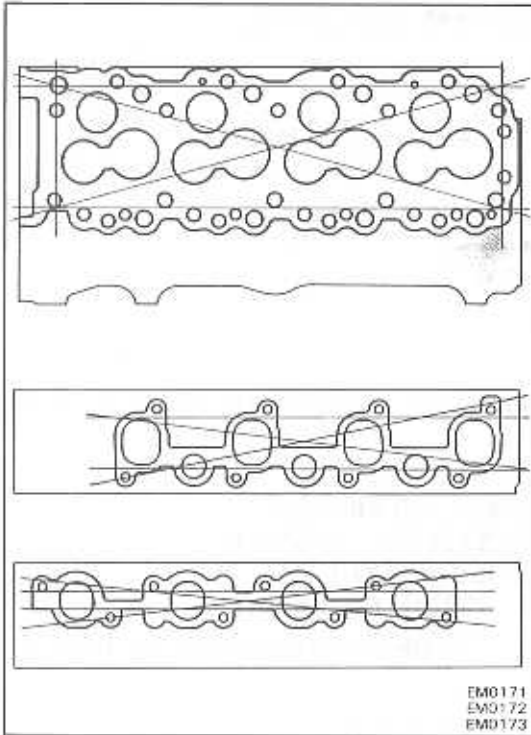

6. INSPECT CYLINDER HEAD FOR FLATNESS

Using a precision straight edge and feeler gauge, measure the surfaces contacting the cylinder block and manifolds for warpage.

Maximum warpage: 0.2 mm (0.008 in.)

If warpage is greater than maximum, replace the cylinder head.

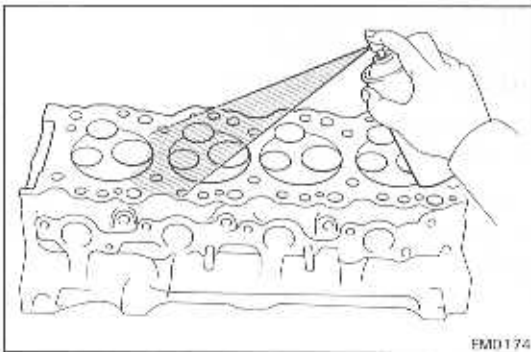

7. INSPECT CYLINDER HEAD FOR CRACKS

Using a dye penetrant, check the combustion chamber, intake and exhaust ports, head surface and the top of the head for cracks.

If a crack is found, replace the cylinder head.

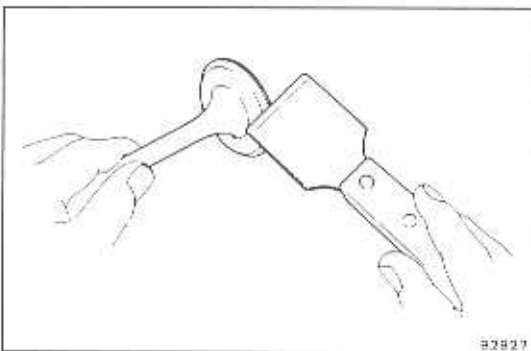

8. CLEAN VALVES

(a) Using a gasket scraper, chip any carbon from the valve head.



(b) Using a wire brush, thoroughly clean the valve.

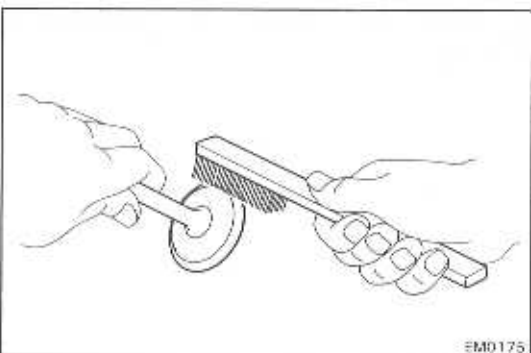

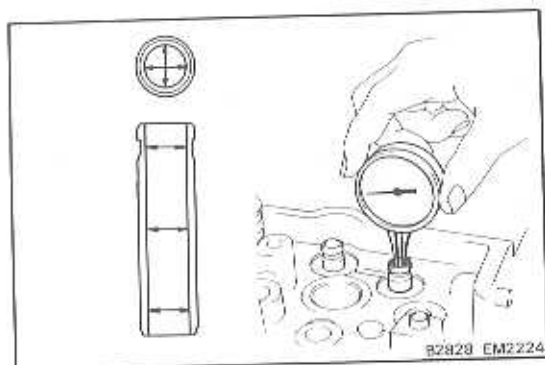

9. INSPECT VALVE STEM AND GUIDE

- (a) Using a dial indicator, measure the inside diameter of the valve guide.

Guide inside diameter: 8.51 – 8.53 mm
(0.3350 – 0.3358 in.)

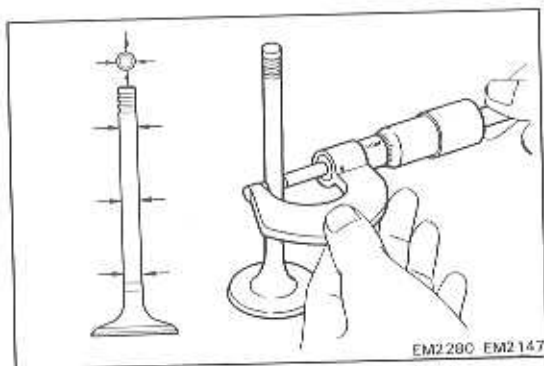

- (b) Using a micrometer, measure the diameter of the valve stem.

Stem diameter:

Intake 8.473 – 8.489 mm
(0.3336 – 0.3342 in.)

Exhaust 8.454 – 8.470 mm
(0.3328 – 0.3335 in.)

- (c) Subtract the valve stem measurement from the valve guide measurement.

Standard stem oil clearance:

Intake 0.021 – 0.057 mm
(0.0008 – 0.0022 in.)

Exhaust 0.040 – 0.076 mm
(0.0016 – 0.0030 in.)

Maximum stem oil clearance:

Intake 0.10 mm (0.0039 in.)

Exhaust 0.12 mm (0.0047 in.)

If the clearance is greater than the above values, re-place the valve and guide.

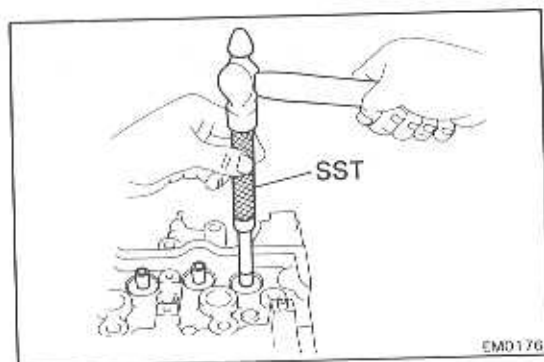

10. IF NECESSARY, REPLACE VALVE GUIDE

- (a) Using SST, and a hammer, drive out the valve guide.
SST 09201-60011

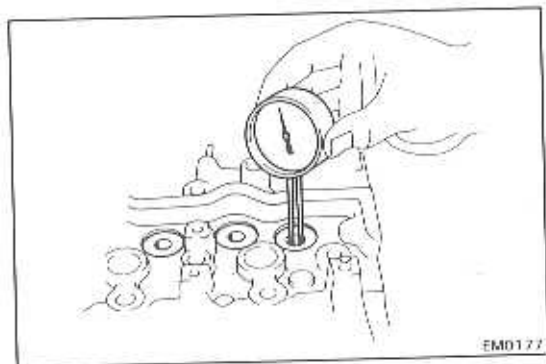

- (b) Using dial indicator, measure the valve guide bore of the cylinder head.

Both intake and exhaust

Guide bore mm (in.)	Guide size
13.994 – 14.018 (0.5509 – 0.5519)	Use STD
Over 14.018 (0.5519)	Use O/S 0.05

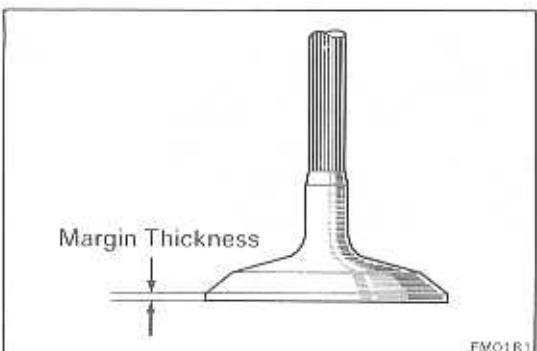
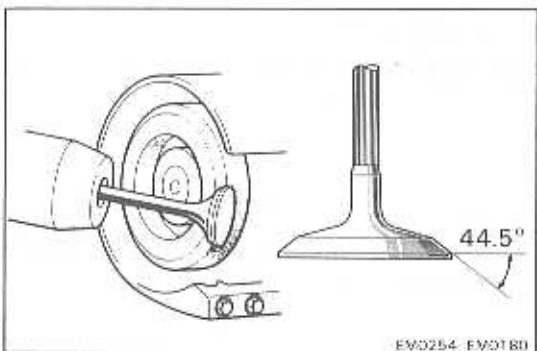
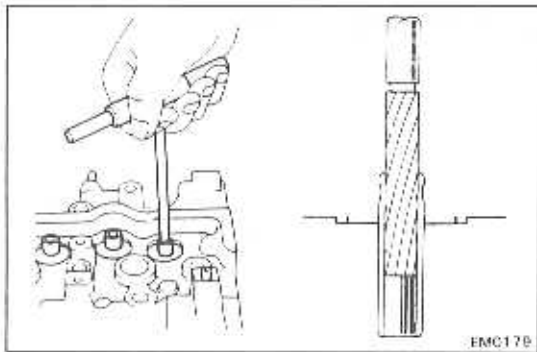
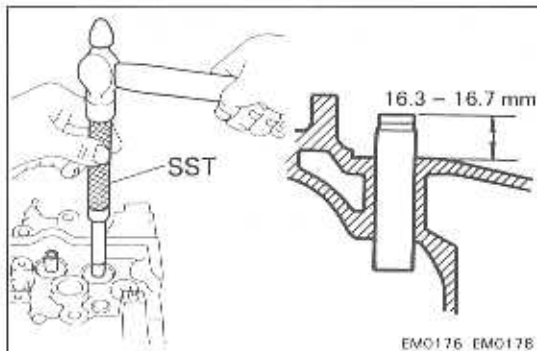

(c) Select a new valve guide.

If the valve guide bore of the cylinder head is more than 14.018 mm (0.5519 in.), machine the bore to the following dimensions.

Rebored cylinder head bushing bore dimensions:
14.044 – 14.068 mm (0.5529 – 0.5539 in.)

(d) Using SST and a hammer, drive in a new valve guide to where there is 16.3 – 16.7 mm (0.642 – 0.657 in.) protruding from the cylinder head.

SST 09201-60011

(e) Using a sharp 8.5 mm reamer, ream the valve guide to obtain the specified clearance between the valve guide and new valve.

Stem oil clearance:

Intake	0.021 – 0.057 mm (0.0008 – 0.0022 in.)
Exhaust	0.040 – 0.076 mm (0.0016 – 0.0030 in.)

11. INSPECT AND GRIND VALVES

(a) Grind valves only enough to remove pits and carbon. Make sure the valves are ground to the correct valve face angle.

Valve face angle: 44.5°

(b) Check the valve head margin.

Minimum margin thickness:

Intake	0.9 mm (0.035 in.)
Exhaust	1.0 mm (0.039 in.)

If the valve head margin thickness is less than minimum, replace the valve.

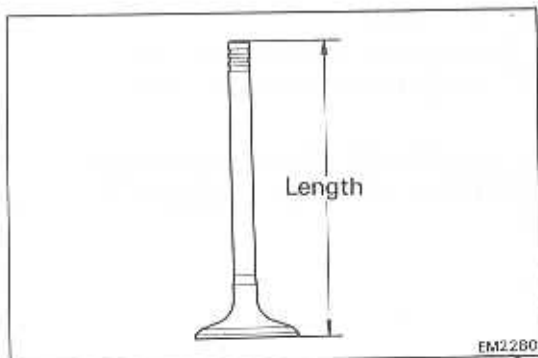

(c) Check the valve overall length.

Standard overall length:

Intake 122.95 mm (4.8405 in.)

Exhaust 122.75 mm (4.8327 in.)

Minimum overall length:

Intake 122.45 mm (4.8209 in.)

Exhaust 122.25 mm (4.8130 in.)

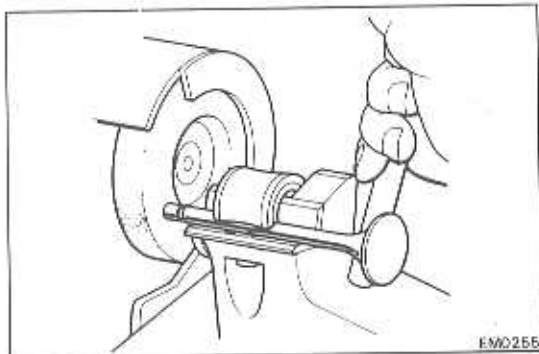

(d) If the valve stem tip is worn, resurface the tip with a grinder or replace the valve.

CAUTION: Do not grind off more than the minimum amount.

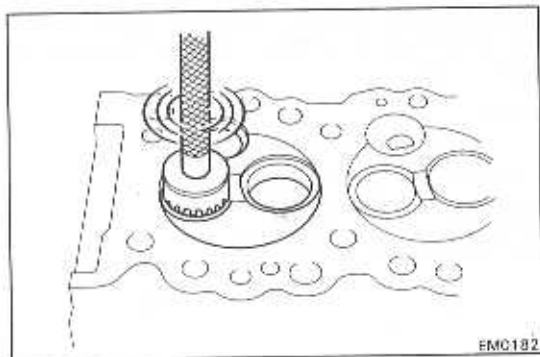

12. INSPECT AND CLEAN VALVE SEATS

(a) Using a 45° cutter, resurface the valve seats. Remove only enough metal to clean the seats.

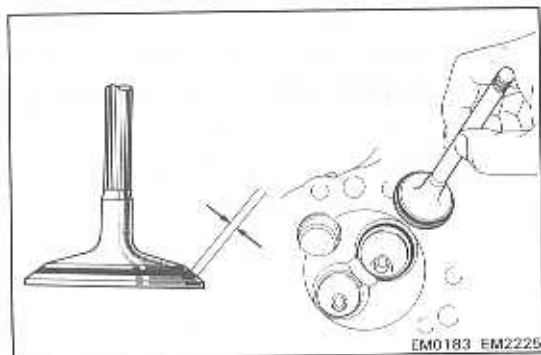

(b) Check the valve seating position.

Apply a thin coat of prussian blue (or white lead) to the valve face. Install the valve. While applying light pressure to the valve, rotate the valve against the seat.

(c) Check the valve face and seat for the following:

- If blue appears 360° around the valve face, the valve is concentric. If not, replace the valve.
- If blue appears 360° around the valve seat, the guide and seat are concentric. If not, resurface the seat.

- Check that the seat contact is on the middle of the valve face with the following width:
1.2 – 1.6 mm (0.047 – 0.063 in.)

If not correct the valve seat as follows:

- (1) If the seating is too high on the valve face, use 30° and 45° cutters to correct the seat.

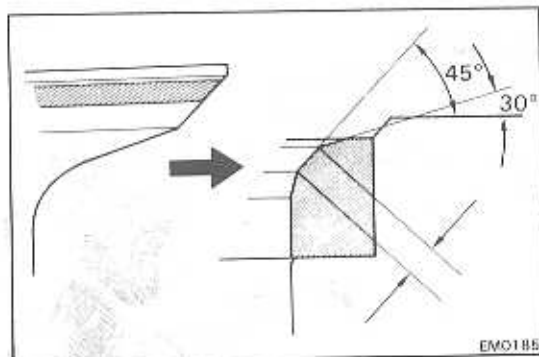

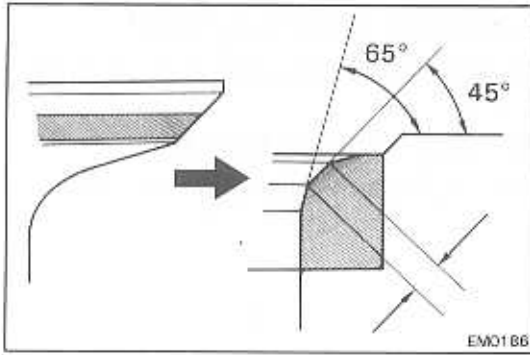

- (2) If seating is too low on the valve face, use 65° and 45° cutters to correct the seat.

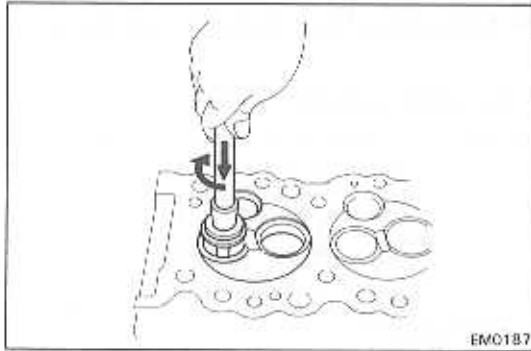

- (d) Hand-lap the valve and valve seat with abrasive compound.

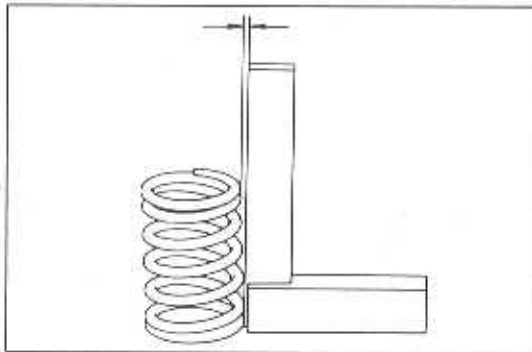

13. INSPECT VALVE SPRINGS

- (a) Using a steel square, measure the squareness of the valve springs.

Maximum squareness: 2.0 mm (0.079 in.)

If squareness is greater than maximum, replace the valve spring.

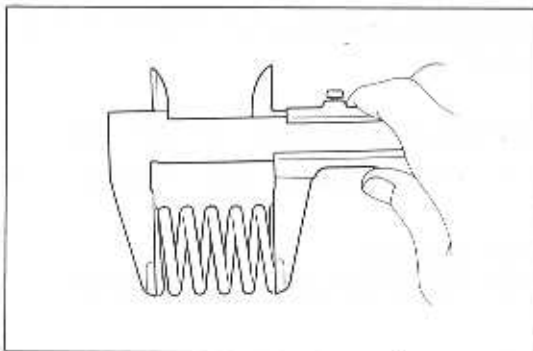

- (b) Using calipers, measure the free length of the valve spring.

Free length: 47.98 mm (1.8890 in.)

If not as specified, replace the valve spring.

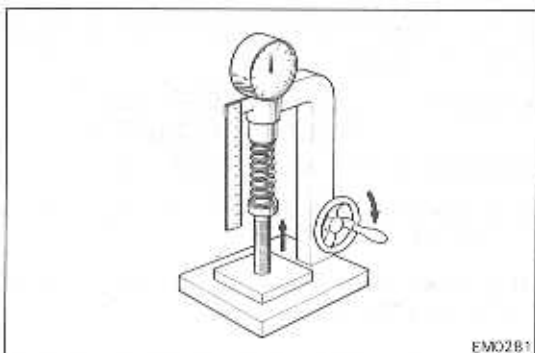

- (c) Using a spring tester, measure the tension of the valve spring at the specified installed length.

Installed tension:

29.2 kg (64.4 lb, 286 N) at 39.3 mm (1.547 in.)

If not as specified, replace the valve spring.

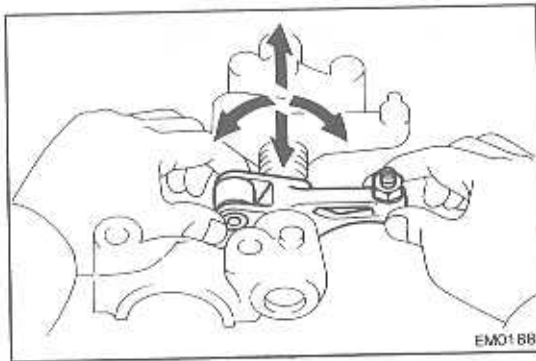

14. INSPECT VALVE ROCKER ARM AND SHAFT

- (a) Check for rocker arm-to-shaft clearance by moving each rocker arm.

If movement is felt, disassemble and check.

- (b) Check that the rocker arm roller turns smoothly.

- (c) Disassemble the rocker arm assembly as shown in the figure.

NOTE: Arrange the disassembled parts in order.

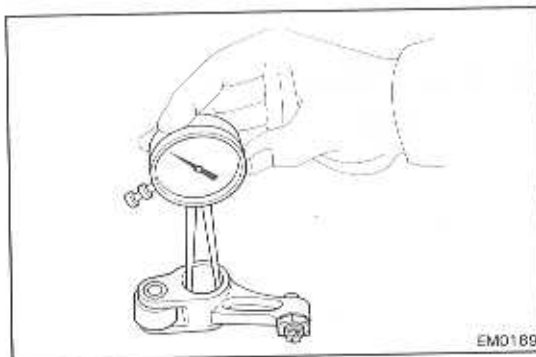
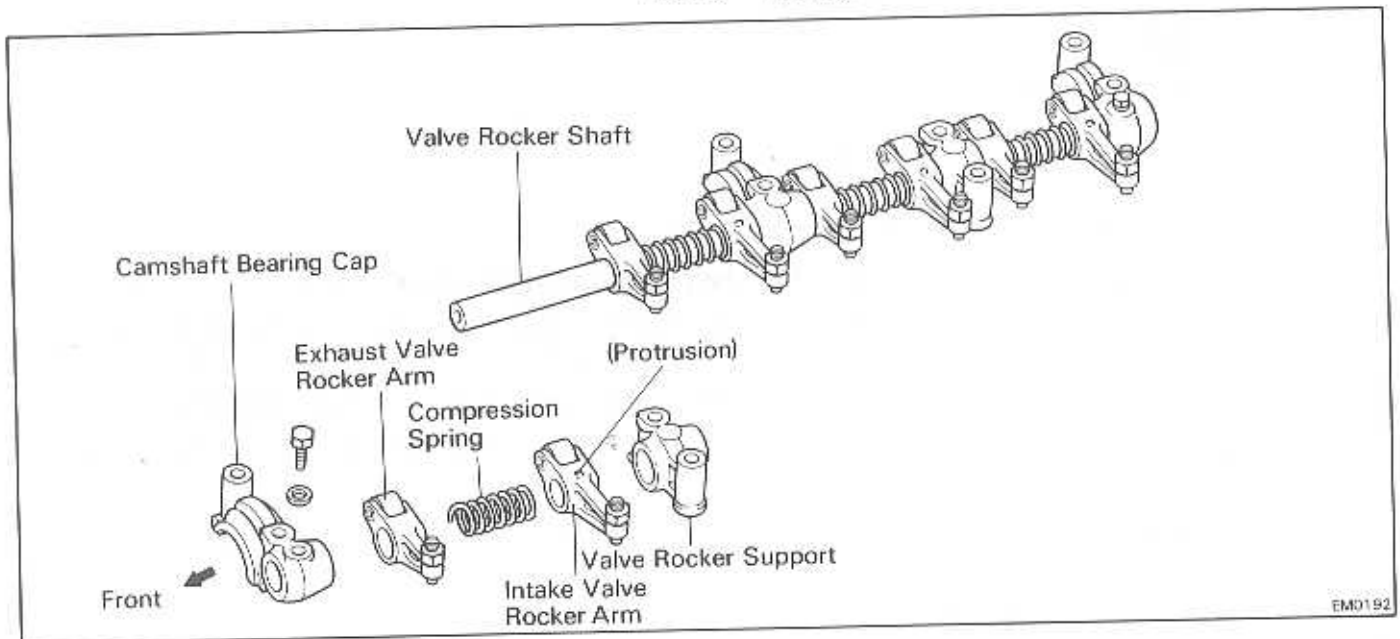

- (d) Using a micrometer, measure the diameter of the rocker arm shaft.

Shaft diameter:

18.464 – 18.483 mm (0.7269 – 0.7277 in.)

- (e) Using dial indicator, measure the inside diameter of the rocker arm.

Rocker arm inside diameter:

18.500 – 18.521 mm (0.7283 – 0.7292 in.)

- (f) Subtract the rocker arm shaft measurement from the rocker arm measurement.

Standard oil clearance: 0.017 – 0.057 mm (0.0007 – 0.0022 in.)

Maximum oil clearance: 0.1 mm (0.004 in.)

If the clearance is greater than maximum, replace the rocker arm and/or shaft.

- (g) Assemble the rocker arm assembly in reverse order as described in step 14-(b).

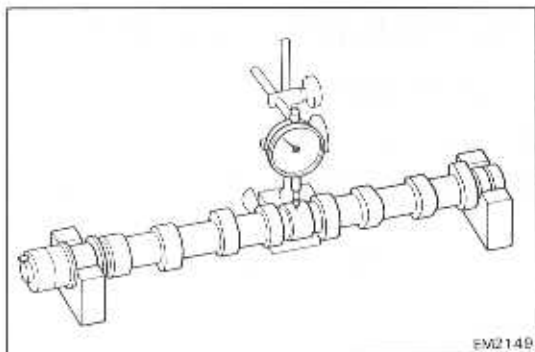

EM2149

15. INSPECT CAMSHAFT

- (a) Place the camshaft on V-blocks and, using a dial indicator, measure the circle runout at the center journal.

Maximum circle runout: 0.1 mm (0.039 in.)

If the circle runout is greater than maximum, replace the camshaft.

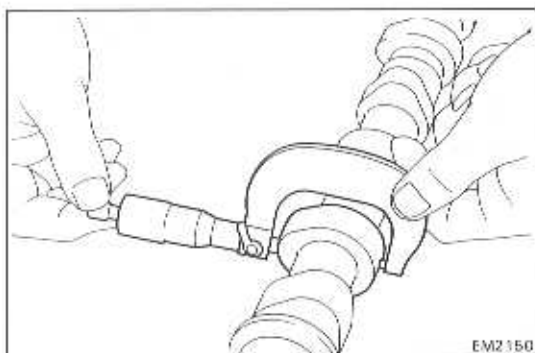

EM2150

- (b) Using a micrometer, measure the cam lobe height.

Minimum cam lobe height:

Intake	L, 2L	46.76 mm (1.8409 in.)
	2L-T	46.29 mm (1.8224 in.)
Exhaust		47.25 mm (1.8602 in.)

If the cam lobe height is less than minimum, replace the camshaft.

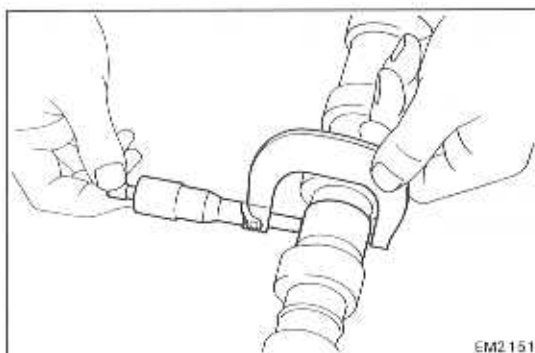

EM2151

- (c) Using a micrometer, measure the journal diameter.

**Journal diameter: 34.969 – 34.985 mm
(1.3767 – 1.3774 in.)**

If the oil clearance even when new bearings are used, is greater than specified, regrind or replace the camshaft.

16. IF NECESSARY, GRIND AND HONE CAMSHAFT JOURNAL

Grind and hone the journals to the undersized finished diameter.

Install new journal bearings.

Bearing size (U/S 0.125, 0.250)

Journal finished diameter:

U/S 0.125	34.844 – 34.860 mm (1.3718 – 1.3724 in.)
	U/S 0.250 34.719 – 34.735 mm (1.3669 – 1.3675 in.)

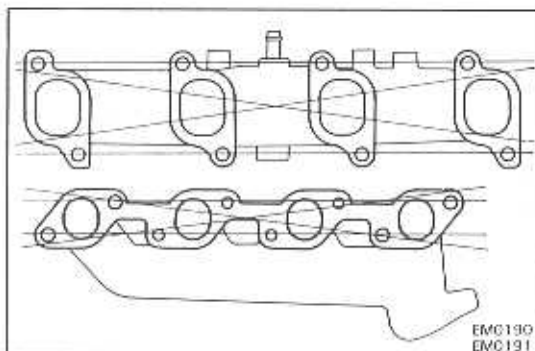
EM0190
EM0191**17. INSPECT INTAKE AND EXHAUST MANIFOLDS**

Using a precision straight edge and feeler gauge, measure the surfaces contacting the cylinder head for warpage.

Maximum manifolds warpage: 0.4 mm (0.016 in.)

If warpage is greater than maximum, replace the manifold.

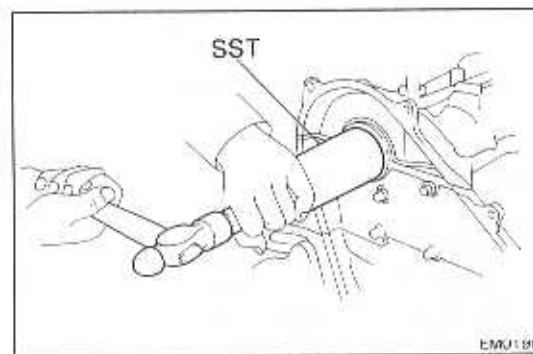
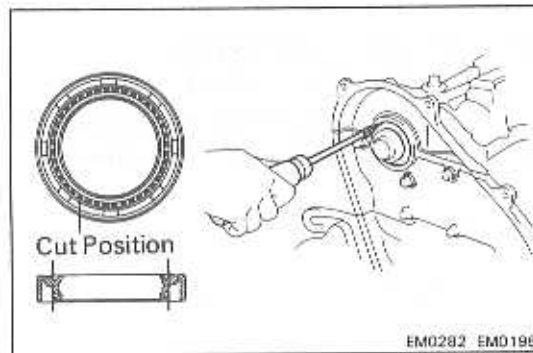
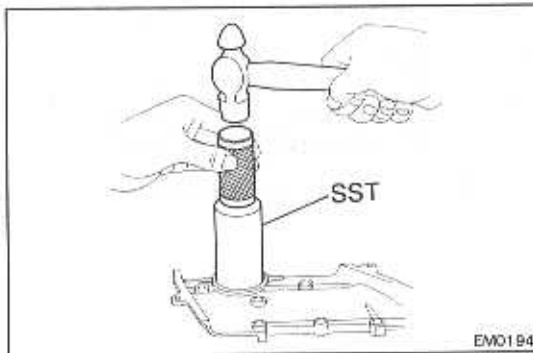
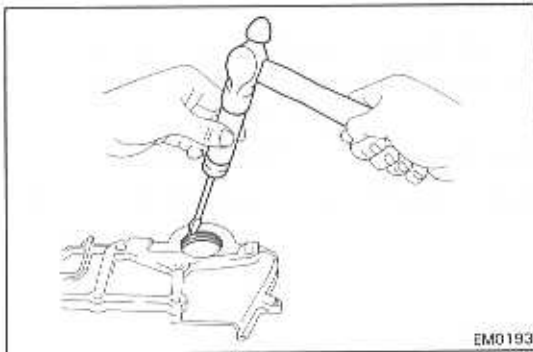

REPLACEMENT OF CAMSHAFT OIL SEAL

NOTE: There are two methods of oil seal replacement.

REPLACE CAMSHAFT OIL SEAL

If camshaft oil seal retainer is removed from cylinder head:

- (a) Using a screwdriver and hammer, drive out the oil seal.
 - (b) Using SST and a hammer, drive in a new oil seal until its surface is flush with the oil seal retainer edge.
- SST 09214-60010
- (c) Apply MP grease to the oil seal.

If camshaft oil seal retainer is installed to cylinder head:

- (a) Using a knife, cut off the oil seal lip.
 - (b) Using a screwdriver, pry out the oil seal.
- CAUTION:** Be careful not to damage the camshaft. Tape the screwdriver.
- (c) Apply MP grease to a new oil seal.
 - (d) Using SST and a hammer, drive in the oil seal until its surface is flush with oil seal retainer edge.
- SST 09214-60010

ASSEMBLY OF CYLINDER HEAD

(See page EM-31)

NOTE:

- Thoroughly clean all parts to be assembled.
- Before installing the parts, apply new engine oil to all sliding and rotating surfaces.
- Replace all gaskets, O-rings and oil seals with new parts.

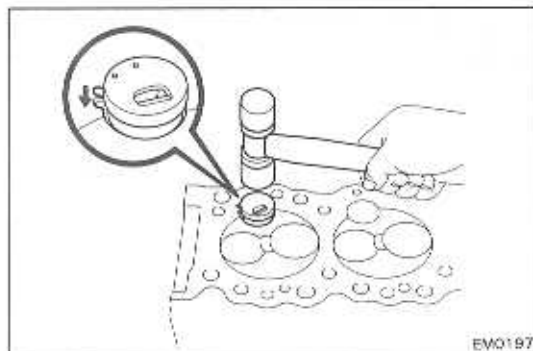

EM0197

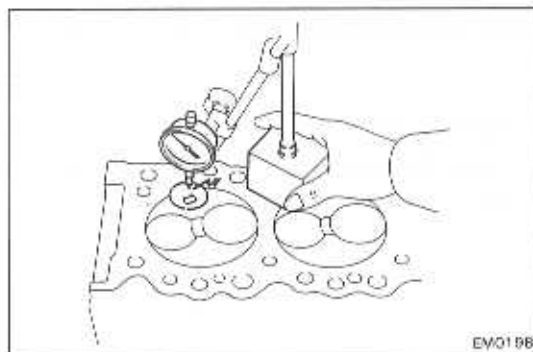

EM0198

1. INSTALL SWIRL COMBUSTION CHAMBERS

- (a) Align the swirl combustion chamber knock pin with the cylinder head notch.
- (b) Using a plastic hammer, drive in the swirl combustion chamber (with the shim).

- (c) Using a dial indicator, check the swirl combustion chamber protrusion.

Combustion chamber protrusion:

0.01 – 0.07 mm (0.0004 – 0.0028 in.)

If the protrusion is not within specification, adjust it with a swirl combustion chamber shim.

Combustion chamber shim thickness:

0.05 mm (0.0020 in.)
 0.10 mm (0.0039 in.)
 0.15 mm (0.0059 in.)
 0.20 mm (0.0079 in.)

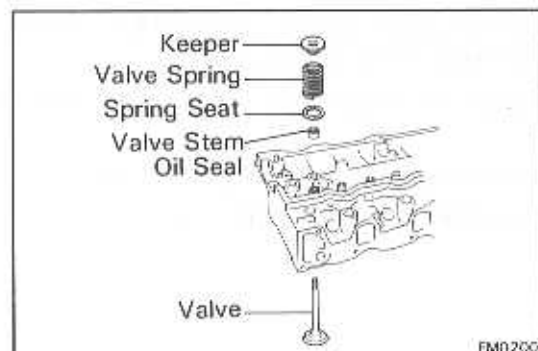

EM0200

2. INSTALL VALVES

- (a) Insert the valve in the cylinder head valve guide. Check the valves are installed in the correct order.
- (b) Install the valve spring seat and new oil seal.
- (c) Install the springs and spring retainers on the valves.

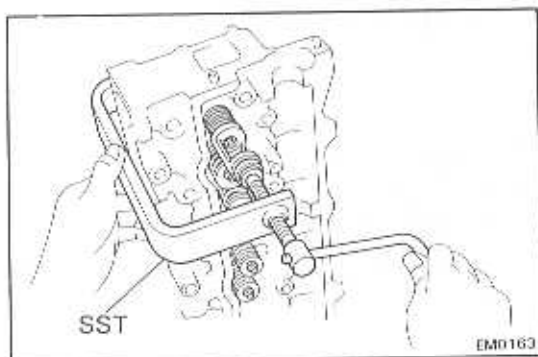

- (d) Using SST, compress the valve spring and place the two keepers around the valve stem.

SST 09202-43013

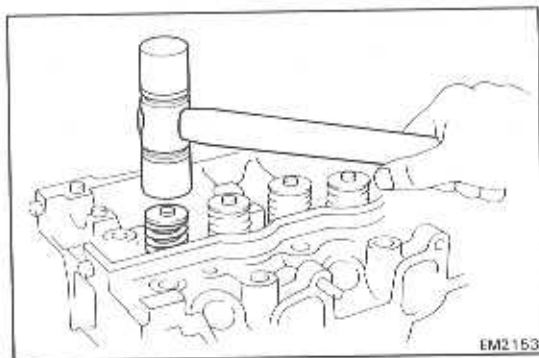

- (e) Using a plastic hammer, lightly tap the stem to assure proper fit.

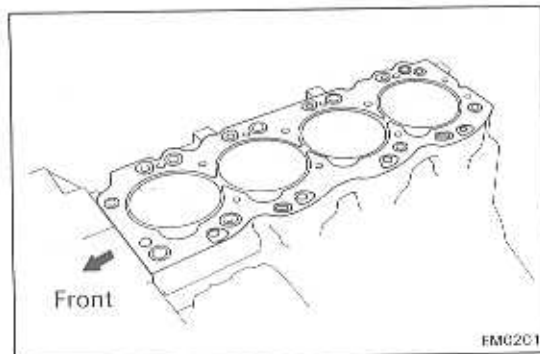

INSTALLATION OF CYLINDER HEAD

(See page EM-31)

1. INSTALL CYLINDER HEAD

- (a) Install a new cylinder head gasket and the head on the cylinder block.

- (b) Apply a light coat of engine oil on the threads and under the head of bolts.

- (c) Install gradually and tighten the eighteen head bolts in three passes and in the sequence shown. Torque the bolts on the final pass.

Torque: 1,200 kg-cm (87 ft-lb, 118 N·m)

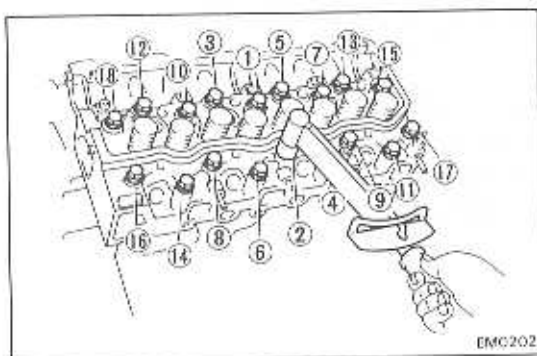

2. INSTALL CAMSHAFT BEARINGS, CAMSHAFT AND VALVE ROCKER SHAFT ASSEMBLY

Upper (ex. No. 1
Camshaft Bearing)
and Lower Bearing

Upper Bearing
(No. 1 Camshaft
Bearing)

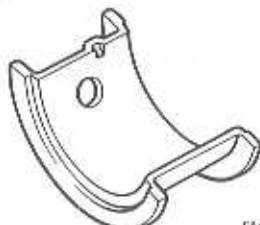

EM0203

- (a) Install the upper bearings to the camshaft bearing caps.
- (b) Install the lower bearings to the cylinder head.
- (c) Place the camshaft in the cylinder head.

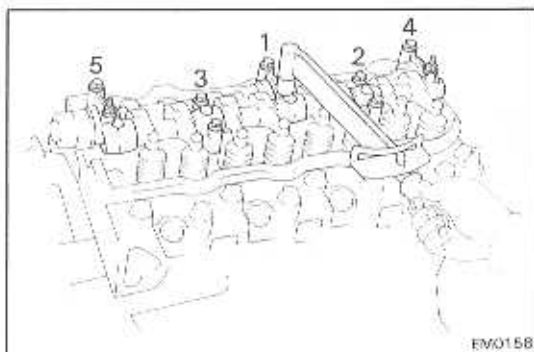

EM0158

- (d) Turn the crankshaft to lower the pistons.
- (e) Install the valve rocker shaft assembly on the cylinder head.
- (f) Gradually install and tighten the ten bolts in three passes in the sequence shown. Torque the bolts on the final pass.

Torque: 195 kg-cm (14 ft-lb, 19 N·m)

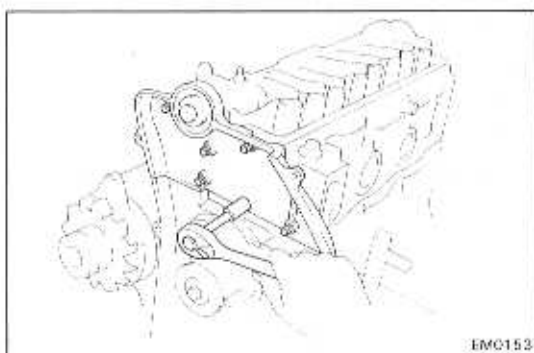

EM0153

3. INSTALL CAMSHAFT OIL SEAL RETAINER

Install a new gasket and the retainer with the six bolts. Torque the bolts.

Torque: 185 kg-cm (13 ft-lb, 18 N·m)

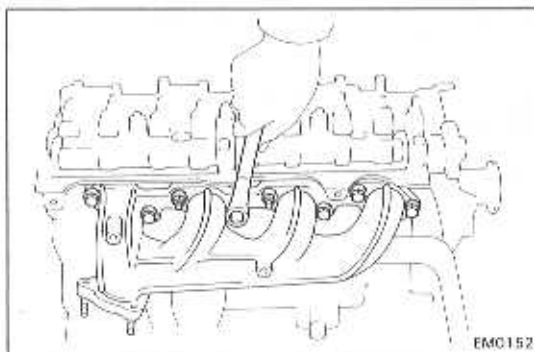

EM0152

4. INSTALL EXHAUST MANIFOLD

(a) Install a new gasket and the exhaust manifold with the six bolts, two plate washers and nuts. Torque the bolts and nuts.

Torque: L, 2L 400 kg-cm (29 ft-lb, 39 N·m)
2L-T 530 kg-cm (38 ft-lb, 52 N·m)

(b) Install the two insulators with the four bolts. Torque the bolts.

Torque: 120 kg-cm (9 ft-lb, 12 N·m)

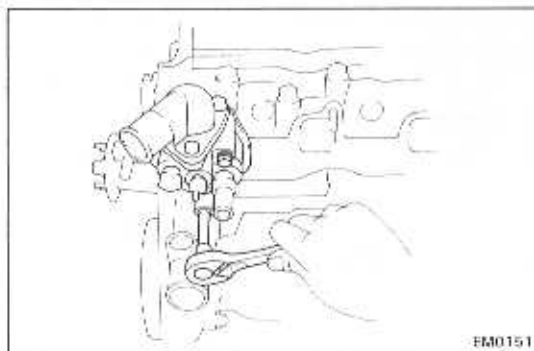

EM0151

5. INSTALL RH ENGINE HANGER

Torque: 380 kg-cm (27 ft-lb, 37 N·m)

6. INSTALL WATER OUTLET ASSEMBLY

Install a new gasket and the water outlet assembly with the two bolts. Torque the bolts.

Torque: 195 kg-cm (14 ft-lb, 19 N·m)

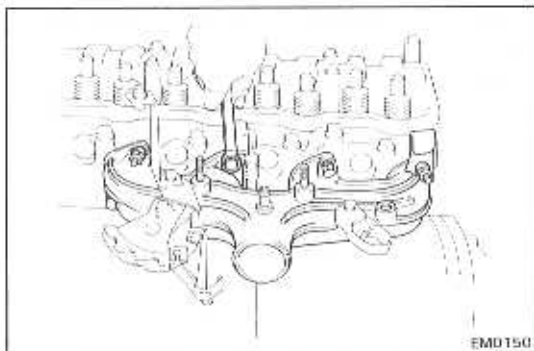

EM0150

7. INSTALL INTAKE MANIFOLD AND LH ENGINE HANGER

Install a new gasket, intake manifold and LH engine hanger with the six bolts and two nuts.

Torque: 240 kg-cm (17 ft-lb, 24 N·m)

8. CONNECT ACCELERATOR CONNECTING ROD

9. INSTALL FOUR INJECTION NOZZLES (See steps 3, 4 on page FU-12)

10. INSTALL FUEL INLET PIPE (See page FU-47)

11. INSTALL FOUR INJECTION PIPES
(See page FU-12)
12. INSTALL CAMSHAFT TIMING PULLEY
(See page EM-26)
13. INSTALL TIMING BELT
(See steps 6 to 16 on pages EM-26 to 30)

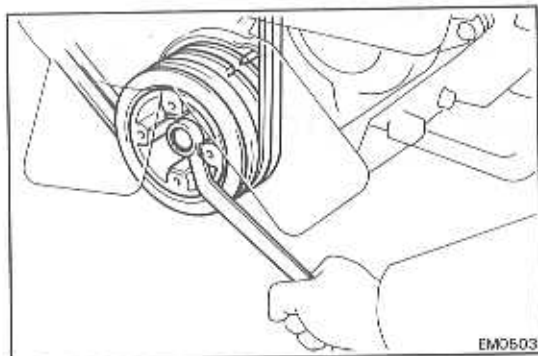

EM0503

14. ADJUST VALVE CLEARANCES

- (a) Set the No. 1 cylinder to TDC/compression.
Align the groove on the pulley with the timing pointer by turning the crankshaft clockwise with a wrench.
- (b) Check that the rocker arms on the No. 1 cylinder are loose and rocker arms on the No. 4 cylinder are tight.
If not, turn the crankshaft one revolution (360°) and align the mark as above.

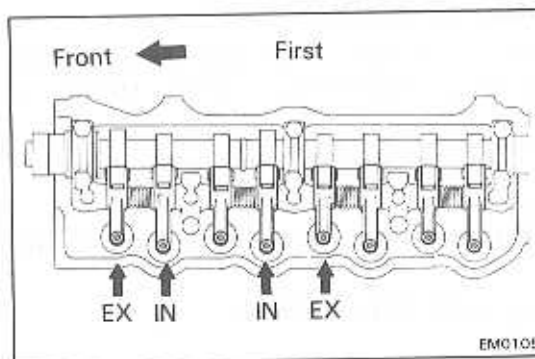

EM0105

- (c) Adjust only those valves indicated by arrows.

Valve clearance (Cold):

Intake 0.27 mm (0.0106 in.)

Exhaust 0.38 mm (0.0150 in.)

NOTE: After installing the cylinder head, warm up the engine and adjust the valve clearance.

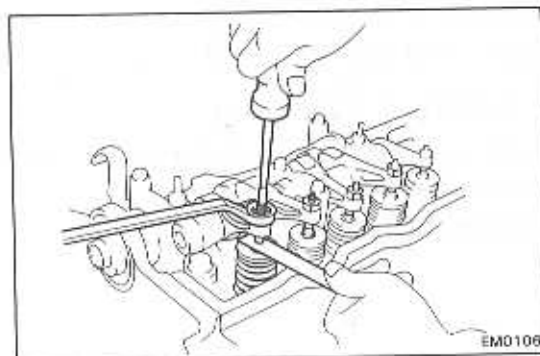

EM0106

- Using a feeler gauge, measure the valve clearance between the valve stem and rocker arm. Loosen the lock nut and turn the adjusting screw to set the proper clearance. Hold the adjusting screw in position and tighten the lock nut.
- Recheck the valve clearance. The feeler gauge should slide with a very slight drag.

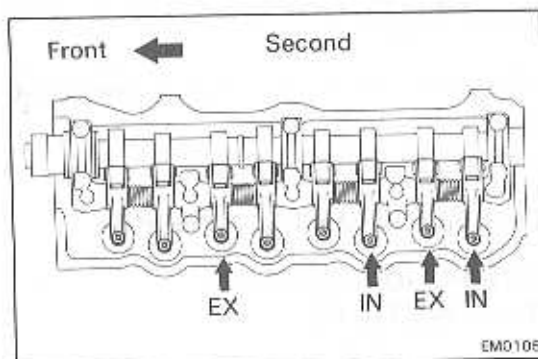

EM0105

- (d) Turn the crankshaft one revolution (360°) and align the timing marks as above.
Adjust only the valves indicated by arrows.

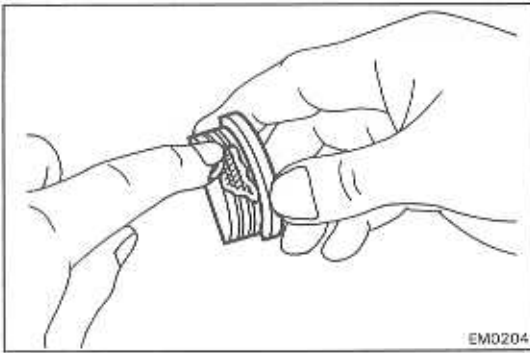
**15. INSTALL HALF CIRCULAR PLUG**

- (a) Apply seal packing black (Part No. 08826-00080) or equivalent to the half circular plug.

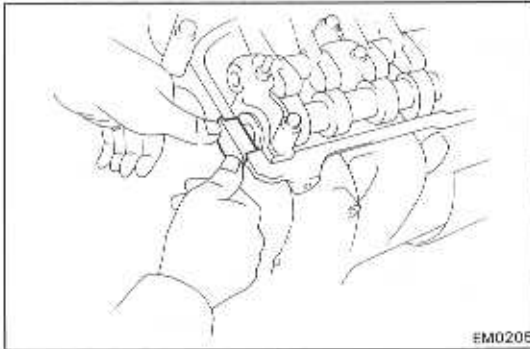

- (b) Install the half circular plug to the cylinder head.

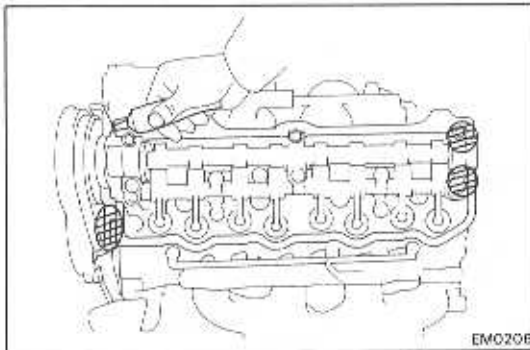
**16. INSTALL CYLINDER HEAD COVER**

- (a) Apply seal packing black (Part No. 08826-00080) or equivalent to the camshaft oil seal retainer, cylinder head and half circular plug as shown.

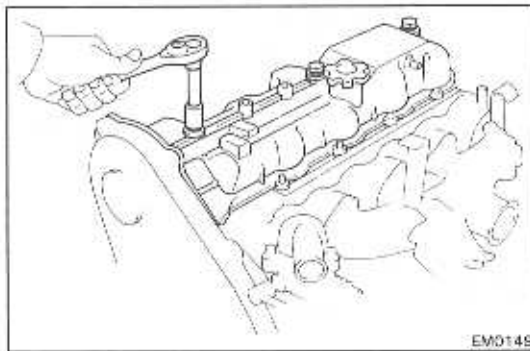

- (b) Install a gasket to the head cover.
- (c) Install the head cover with the three seal washers and cap nuts.
- (d) Install the remaining two timing gear cover mount bolts.

CYLINDER BLOCK COMPONENTS

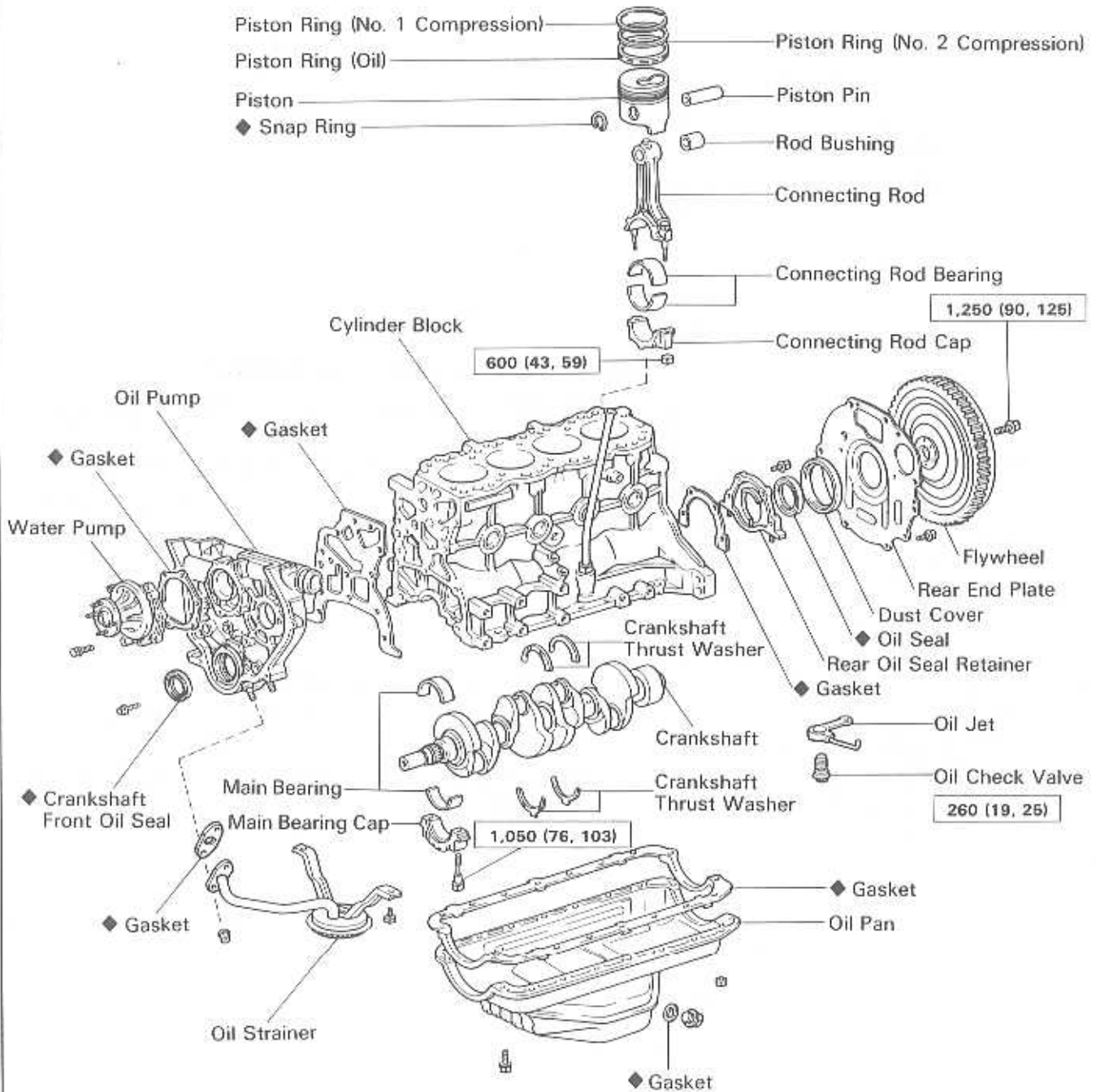

kg-cm (ft-lb, N·m) : Specified torque

◆ Non-reusable part

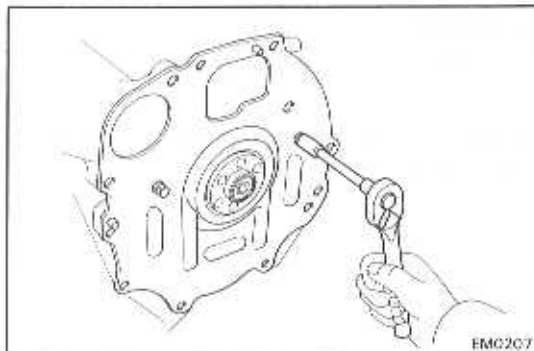

DISASSEMBLY OF CYLINDER BLOCK

(See page EM-50)

1. REMOVE FLYWHEEL OR DRIVE PLATE

2. REMOVE REAR END PLATE

Remove the two bolts, end plate and dust cover.

3. INSTALL ENGINE TO ENGINE STAND FOR DISASSEMBLY

4. REMOVE CYLINDER HEAD

(See steps 1, 3 to 7, 12, 14 and 16 on pages EM-32 to 35)

5. REMOVE OIL PUMP

(See steps 1 to 7 on pages LU-4 and 5)

6. REMOVE REAR OIL SEAL RETAINER

Remove the four bolts, retainer and gasket.

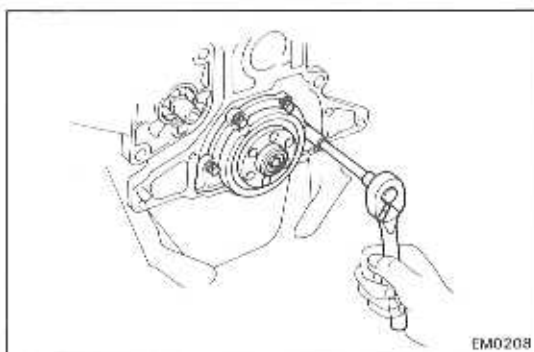

7. CHECK CONNECTING ROD THRUST CLEARANCE

Using a dial indicator, measure the thrust clearance while moving the rod back and forth.

Standard thrust clearance: 0.08 – 0.20 mm
(0.0031 – 0.0079 in.)

Maximum thrust clearance: 0.3 mm (0.012 in.)

If the clearance is greater than the maximum, replace the connecting rod and/or crankshaft.

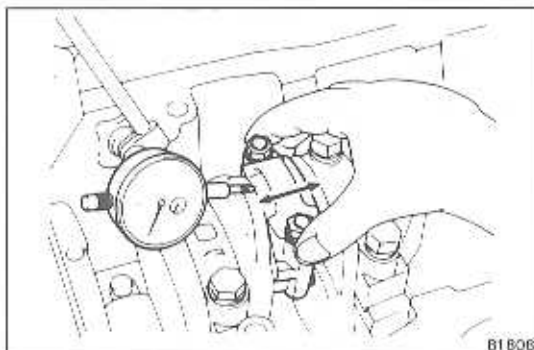

8. REMOVE CONNECTING ROD CAPS WITH LOWER BEARING AND CHECK OIL CLEARANCE

(a) Place matchmarks on the rod and cap.

(b) Remove the rod nuts.

(c) Lightly tap the rod bolts and lift off the caps with the bearing.

NOTE: Keep the bearing inserted with the cap.

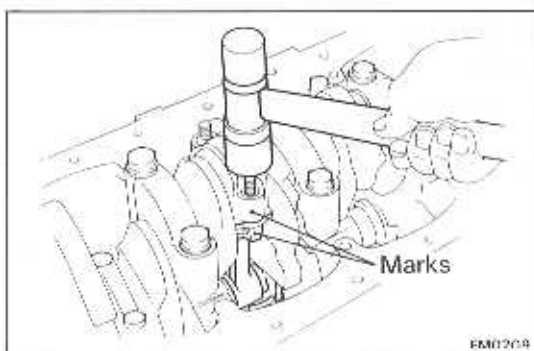

(d) Cover the rod bolts with a short piece of hose to protect the crankshaft from damage.

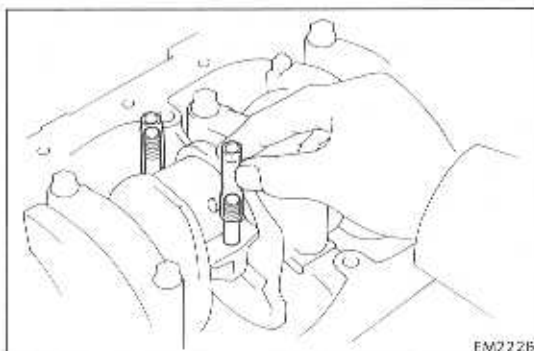

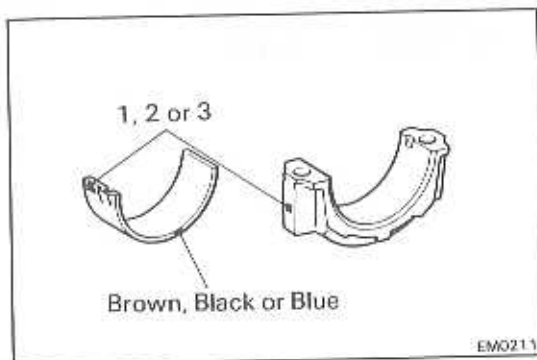
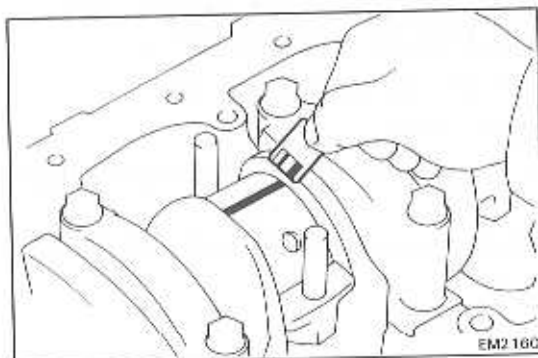
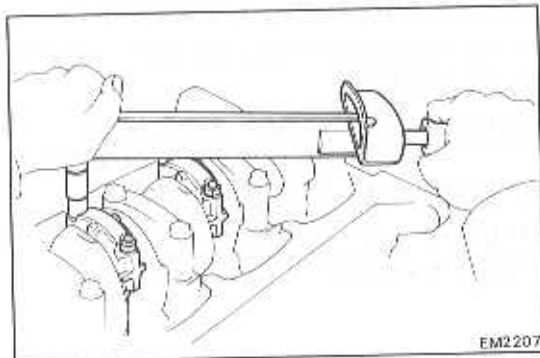
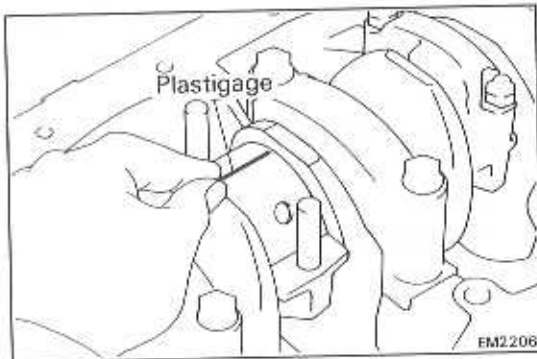
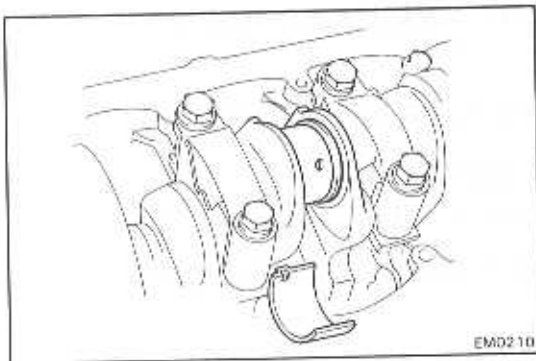

- (e) Clean each crank pin and bearing.
- (f) Check each crank pin and bearing for pitting and scratches.

If the crank pin and bearing are damaged, grind or replace the crankshaft and replace the bearing.

- (g) Lay a strip of Plastigage across the crank pin.

- (h) Install the rod caps (See page EM-67)

Torque: 600 kg-cm (43 ft-lb, 59 N·m)

NOTE: Do not turn the crankshaft.

- (i) Remove the rod cap.
- (j) Measure the Plastigage at its widest point.

**Standard oil clearance: 0.036 – 0.064 mm
(0.0014 – 0.0025 in.)**

Maximum oil clearance: 0.1 mm (0.004 in.)

If the clearance is greater than maximum, replace the bearing. Grind the crank pins or replace the crankshaft as required.

NOTE: There six different standard bearings, distinguished numerically (1, 2 and 3) and by color (brown, black and blue).

For 2L-T engines, replace bearing with one having the same number as marked on the bearing cap. For L and 2L engines, replace with one having the color with corresponds to the number on the bearing cap, i. e., 1 with brown, 2 with black, 3 with blue.

- (k) Completely remove the Plastigage.

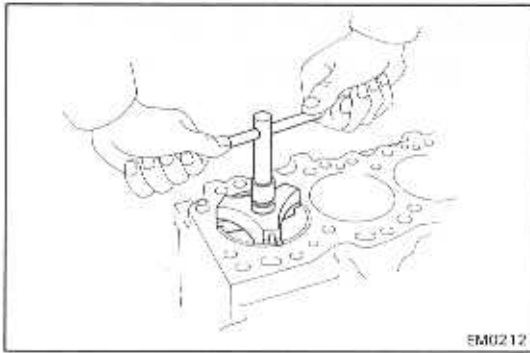

EM0212

9. PUSH OUT PISTON AND CONNECTING ROD ASSEMBLY WITH UPPER BEARING

- Remove all the carbon from the piston ring ridge.
- Cover the rod bolts. (See page EM-51)
- Push out the piston and rod assembly with the bearing through the top of the cylinder block.

NOTE:

- Keep the bearing inserted with the rod.
- Arrange the piston and rod assembly in order.

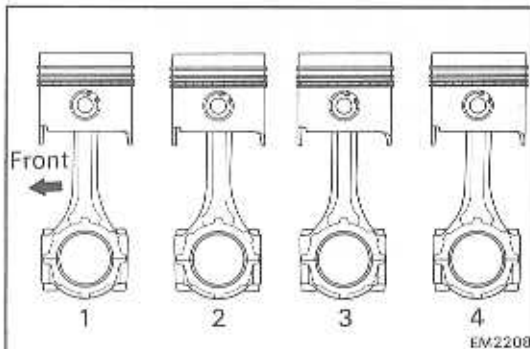

EM2209

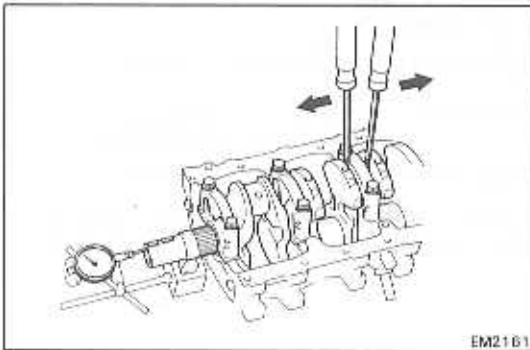

EM2161

10. CHECK CRANKSHAFT THRUST CLEARANCE

Using a dial indicator, measure the thrust clearance while prying the crankshaft back and forth with a screwdriver.

Standard thrust clearance: 0.04 – 0.25 mm
(0.0016 – 0.0098 in.)

Maximum thrust clearance: 0.3 mm (0.012 in.)

If the clearance is greater than maximum, replace the thrust washers as a set.

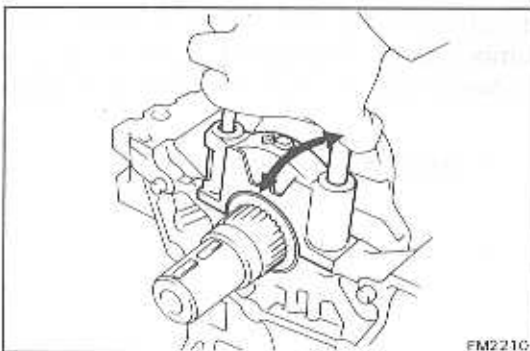

FM2210

11. REMOVE MAIN BEARING CAPS WITH LOWER BEARING AND CHECK OIL CLEARANCE

- Loosen the bolts until the threads no longer mesh.
- Grasping the bolts together, pull off bearing cap.

NOTE: Keep the bearing inserted with the caps.

- Lift out the crankshaft.

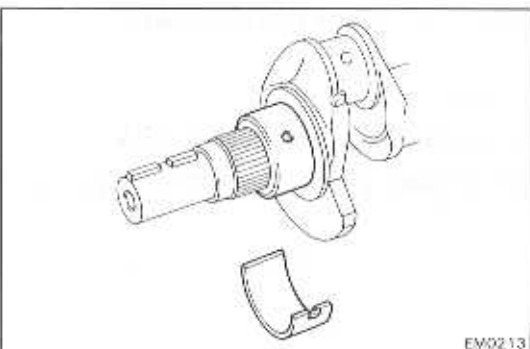

EM0213

- Clean each journal and bearing.
- Check each journal and bearing for pitting and scratches.

If the journal and bearing are damaged, grind or replace the crankshaft and replace the bearing.

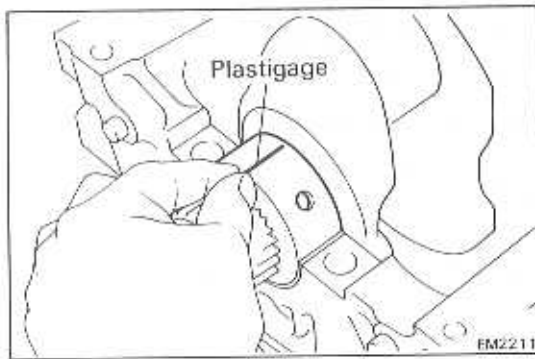

- (f) Place the crankshaft on the cylinder block.
 (g) Lay a strip of Plastigage across each journal.

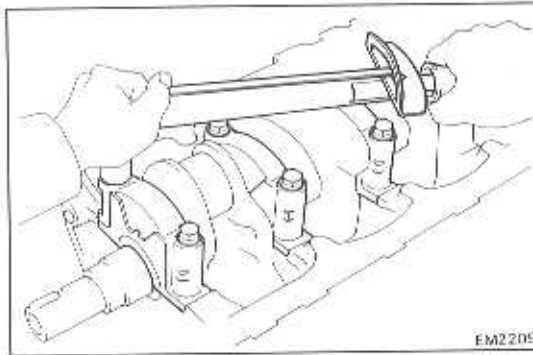

- (h) Install the bearing cap (See page EM-66)
Torque: 1,050 kg-cm (76 ft-lb, 103 N-m)
NOTE: Do not turn the crankshaft.

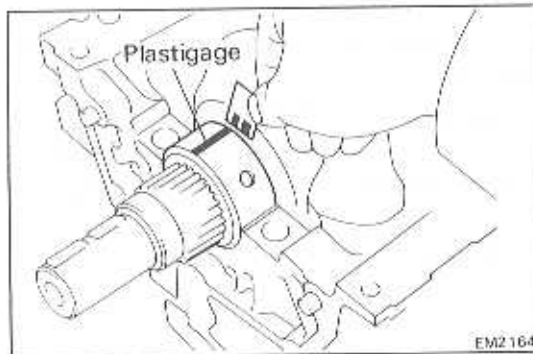

- (i) Remove the bearing cap.
 (j) Measure the Plastigage at its widest point.

Standard oil clearance: 0.034 – 0.065 mm
(0.0013 – 0.0026 in.)
Maximum oil clearance: 0.1 mm (0.004 in.)

If the clearance is greater than maximum, replace the bearing. Grind the journals or replace the crankshaft as required.

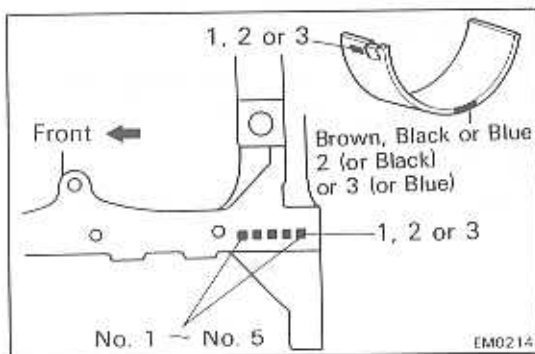

NOTE: If using a standard bearing, replace with one having the same number as marked on the cylinder block or having its corresponding color, i. e., 1 or brown, 2 or black, 3 or blue.

- (k) Completely remove the Plastigage.

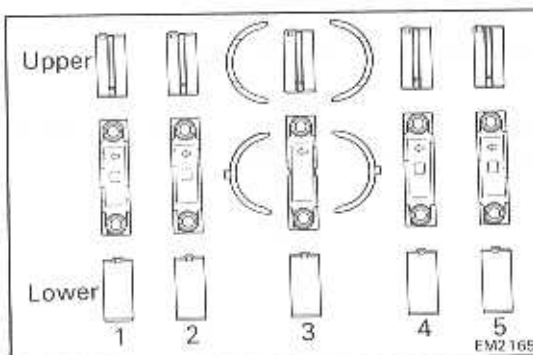

12. REMOVE CRANKSHAFT AND UPPER MAIN BEARINGS

- (a) Lift out the crankshaft.
 (b) Remove the bearing from the cylinder block.

NOTE: Arrange the caps, bearings and thrust washers in order.

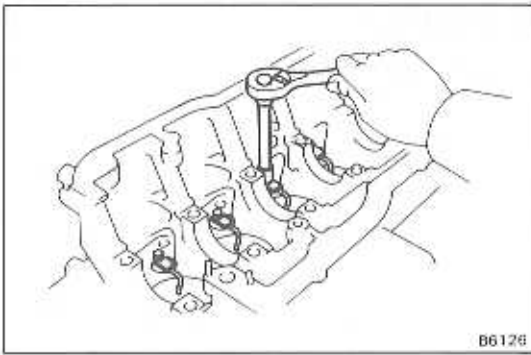

B6128

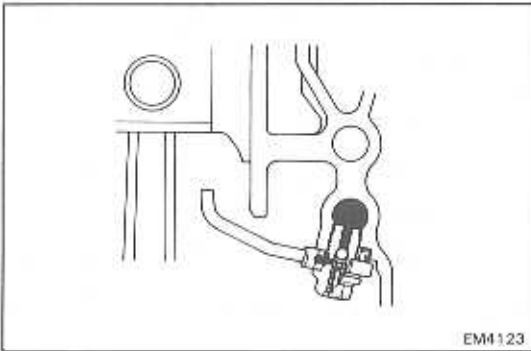
13. REMOVE OIL CHECK VALVES AND OIL JETS

EM123

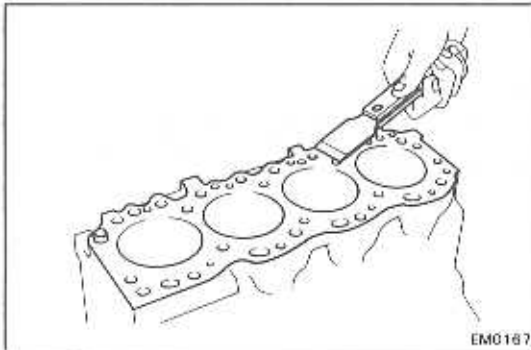

EM0167

INSPECTION OF CYLINDER BLOCK**1. REMOVE GASKET MATERIAL**

Using a gasket scraper, remove all gasket material from the cylinder block surface.

2. CLEAN CYLINDER BLOCK

Using a soft brush and solvent, clean the block.

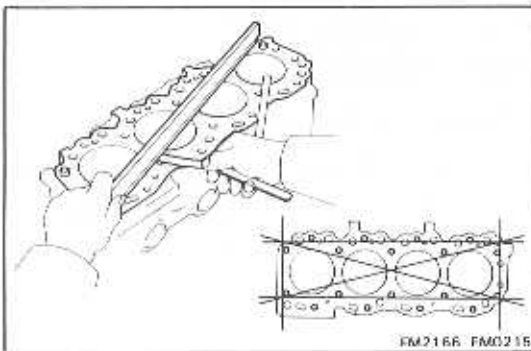

FM2166 FM0215

3. INSPECT TOP OF CYLINDER BLOCK

Using a precision straight edge and feeler gauge, measure the surfaces contacting the cylinder head gasket for warpage.

Maximum warpage: 0.2 mm (0.008 in.)

If warpage is greater than maximum, replace the cylinder block.

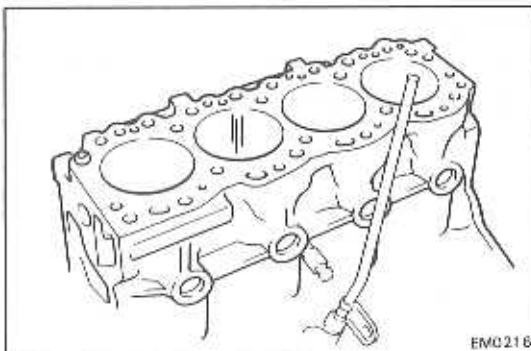

EM0216

4. INSPECT CYLINDERS

Visually check the cylinder for vertical scratches.

If deep scratches are present, rebore all four cylinders.

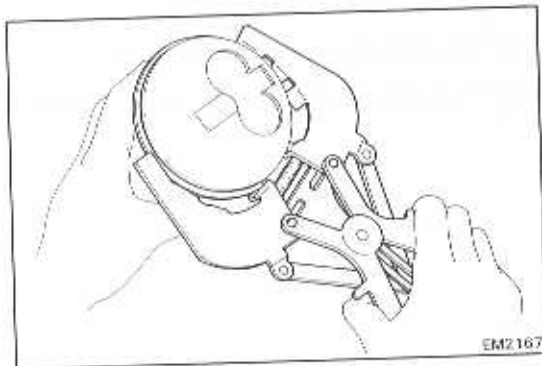
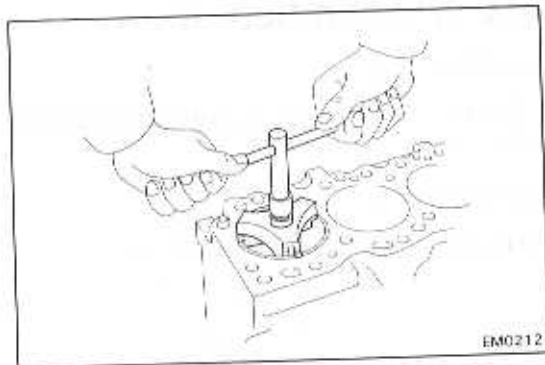
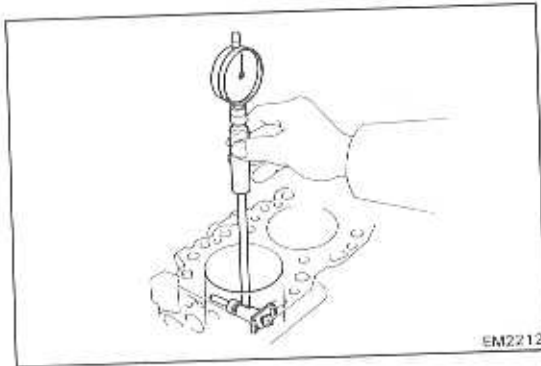
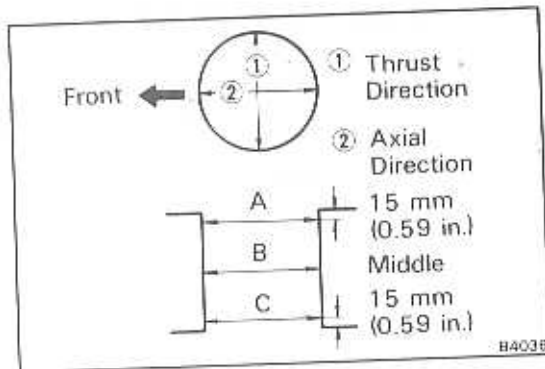

5. INSPECT CYLINDER BORES

Using a cylinder gauge, measure the cylinder bore at positions A, B and C in the thrust and axial directions.

Standard diameter

Piston size	Cylinder bore mm (in.)	
	L	2L, 2L-T
STD	90.000 – 90.030 (3.5433 – 3.5445)	92.000 – 92.030 (3.6220 – 3.6232)
O/S 0.50	90.500 – 90.530 (3.5630 – 3.5642)	92.500 – 92.530 (3.6417 – 3.6429)

Maximum diameter

Piston size	Cylinder bore mm (in.)	
	L	2L, 2L-T
STD	90.23 (3.5524)	92.23 (3.6311)
O/S 0.50	90.73 (3.5720)	92.73 (3.6508)

If the diameter is greater than maximum of the STD size, rebore all four cylinders.

If the diameter is greater than maximum of the O/S 0.50, replace the cylinder block.

6. REMOVE CYLINDER RIDGE

If the wear is less than 0.2 mm (0.008 in.), use a ridge reamer to machine the piston ring ridge at the top of the cylinder.

DISASSEMBLY OF PISTON AND CONNECTING ROD ASSEMBLY

1. CHECK FIT BETWEEN PISTON AND PIN

Try to move the piston back and forth on the piston pin. If any movement is felt, replace the piston and pin.

2. REMOVE PISTON RINGS

Using a piston ring expander, remove the piston rings. Keep the rings separate for each cylinder.

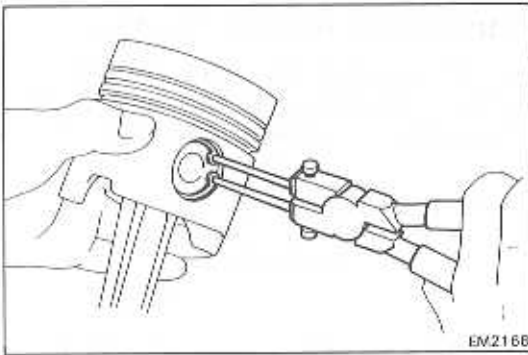

3. DISCONNECT CONNECTING ROD FROM PISTON

- (a) Using needle-nose pliers, remove the snap rings.

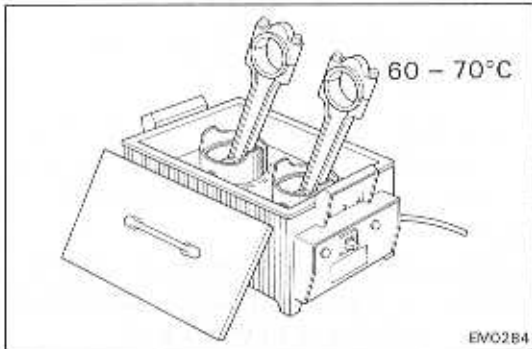

- (b) Gradually heat the piston to about 60 - 70°C (140 - 158°F).

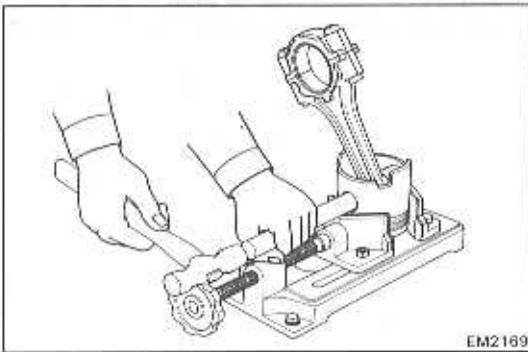

- (c) Using a plastic-faced hammer and brass bar, lightly tap out the piston pin and remove the connecting rod.

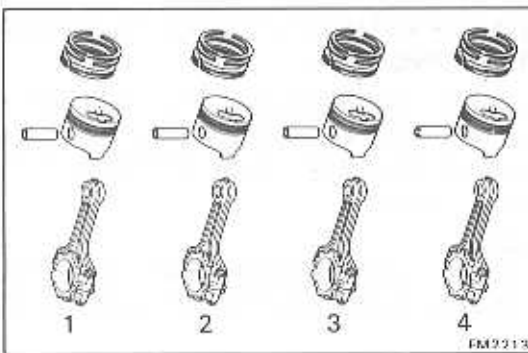

NOTE:

- The piston and pin are a matched set.
- Keep the piston, pin, rings and connecting rod together for each cylinder.

INSPECTION OF PISTON AND CONNECTING ROD ASSEMBLY

1. CLEAN PISTON

- (a) Scrape carbon from the piston top.
- (b) Using a groove cleaning tool or broken ring, clean the ring grooves.
- (c) Using solvent and brush, thoroughly clean the piston.

CAUTION: Do not use a wire brush.

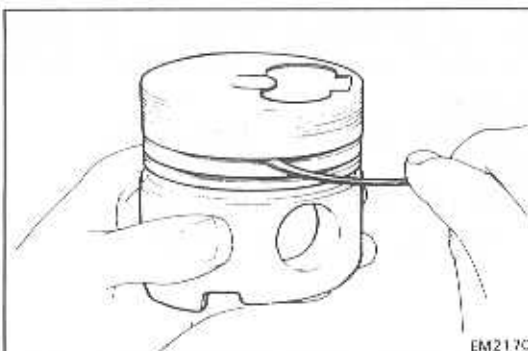

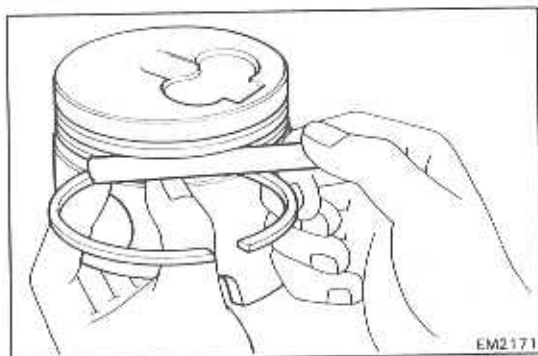
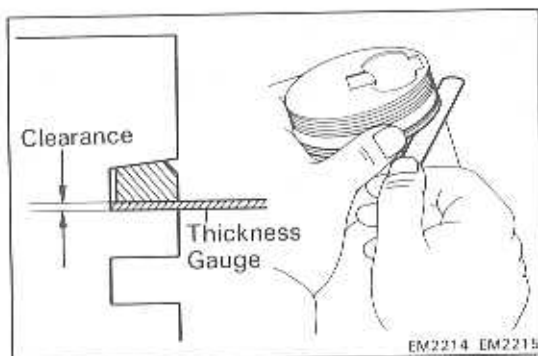
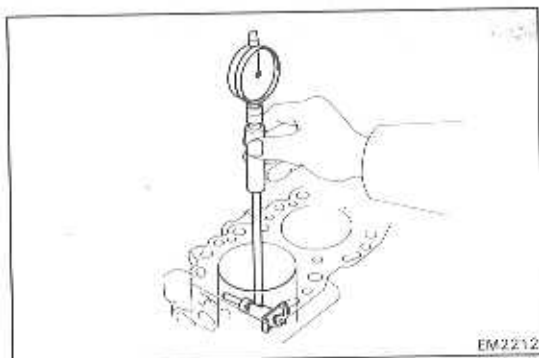
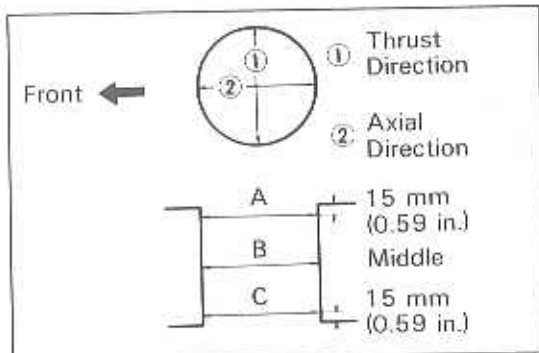
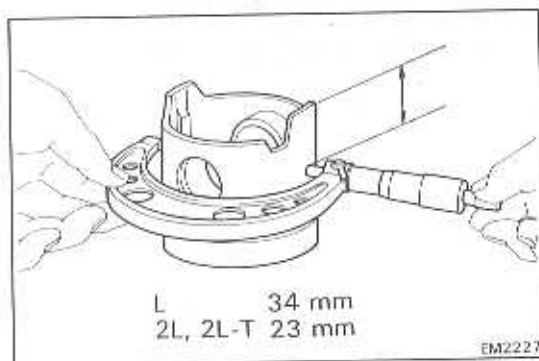

2. INSPECT PISTON DIAMETER AND CLEARANCE

- (a) Using a micrometer, measure the piston diameter at a right angle to the piston pin hole center line 34 mm (1.34 in.) or 23 mm (0.91 in.) below the skirt bottom edge.

Standard diameter

Piston size	Piston bore mm (in.)	
	L	2L, 2L-T
STD	89.955 – 89.985 (3.5415 – 3.5427)	91.940 – 91.970 (3.6197 – 3.6209)
O/S 0.50	90.455 – 90.485 (3.5612 – 3.5624)	92.440 – 92.470 (3.6394 – 3.6405)

- (b) Measure the cylinder bore diameter in the thrust directions (See page EM-56) and subtract the piston diameter measurement from the cylinder diameter.

Standard clearance:

L 0.035 – 0.055 mm (0.0014 – 0.0022 in.)

2L, 2L-T 0.050 – 0.070 mm (0.0020 – 0.0028 in.)

Maximum clearance: 0.14 mm (0.0055 in.)

If the clearance is greater than maximum, replace the piston, or rebore all four cylinders and replace all four pistons.

3. INSPECT CLEARANCE BETWEEN PISTON RING LAND AND NEW PISTON RING

- (a) Install the No. 1 ring to the piston and, using a feeler gauge, measure the No. 1 ring clearance between the ring land and new piston ring when the ring is flush with the piston surface.

No. 1 ring clearance:

L 0.010 – 0.055 mm (0.0004 – 0.0022 in.)

2L, 2L-T 0.020 – 0.065 mm (0.0008 – 0.0026 in.)

- (b) Using a feeler gauge, measure the No. 2 and oil ring clearances between the ring land and new piston ring.

No. 2 ring clearance:

0.040 – 0.100 mm (0.0016 – 0.0039 in.)

Oil ring clearance:

0.030 – 0.070 mm (0.0012 – 0.0028 in.)

If not within specification, replace the piston.

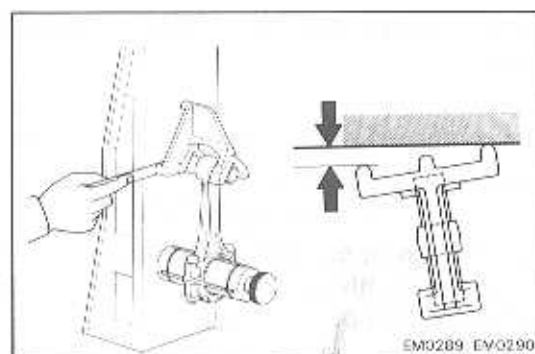
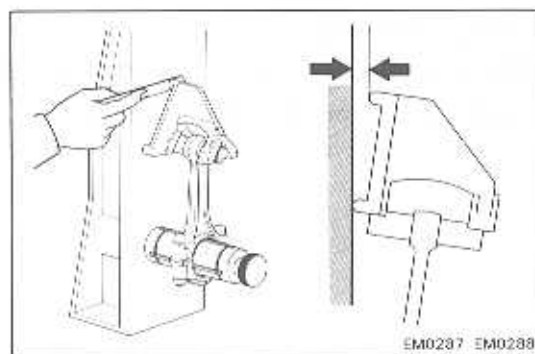
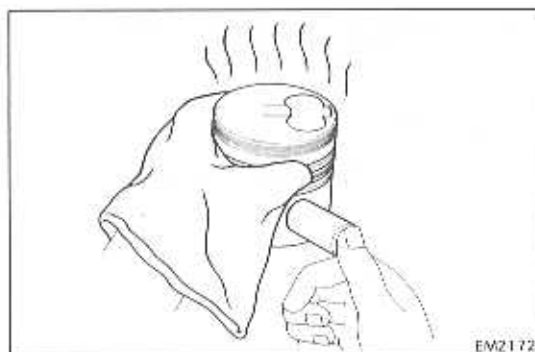
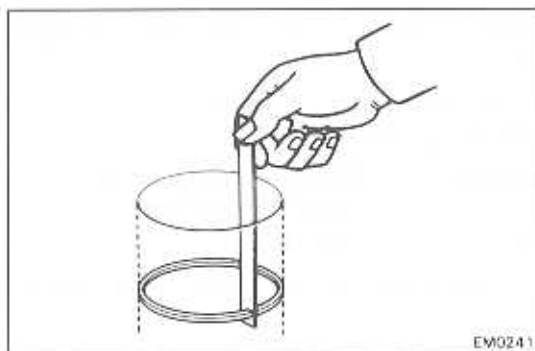
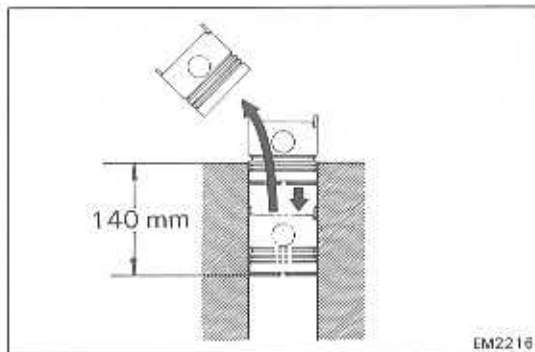

4. INSPECT PISTON RING END GAP

- Insert a piston ring into the cylinder bore.
- Using a piston, push the piston ring a little beyond the bottom of the ring travel.
(140 mm (5.51 in.) from top surface of cylinder block)
- Using a feeler gauge, measure the end gap.

Piston ring end gap mm (in.)

Item	Piston ring	L	2L, 2L-T
Standard	No.1	0.30 - 0.57 (0.0118 - 0.0224)	0.35 - 0.62 (0.0138 - 0.0244)
	No.2	0.20 - 0.52 (0.0079 - 0.0205)	0.20 - 0.47 (0.0079 - 0.0185)
	Oil	0.20 - 0.52 (0.0079 - 0.0205)	
Maximum	No.1	1.30 (0.051)	
	No.2	1.12 (0.044)	1.07 (0.042)
	Oil	1.12 (0.044)	

If the gap exceeds the specified maximum, replace the piston ring.

If the gap exceeds the specified maximum even with a new piston ring, rebore the cylinder and use an o/s piston ring.

5. CHECK PISTON PIN FIT

At 60 - 70°C (140 - 158°F) you should be able to push the pin into the piston with your thumb.

If the pin can be installed at a normal temperature, replace the piston and pin.

6. INSPECT CONNECTING RODS

- Using a rod aligner, check the connecting rod alignment.

- Check for bend.

Maximum bend:

0.05 mm (0.0020 in.) per 100 mm (3.94 in.)

- Check for twist.

Maximum twist:

0.15 mm (0.0059 in.) per 100 mm (3.94 in.)

If the rod is bent or twisted, replace the connecting rod.

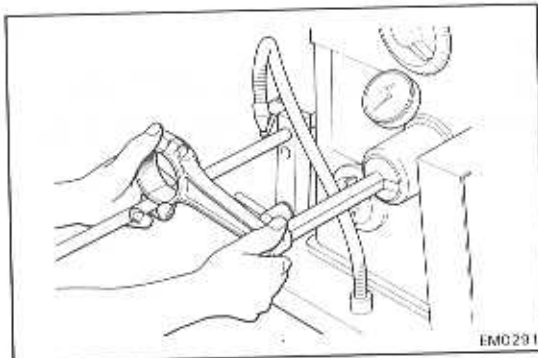
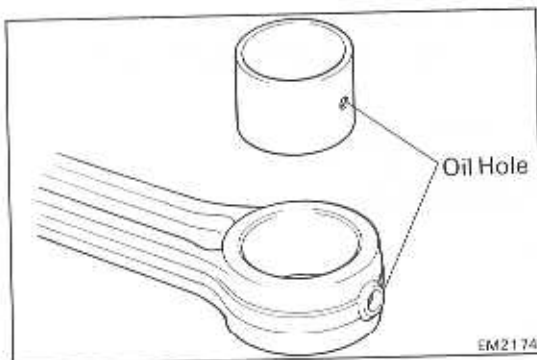
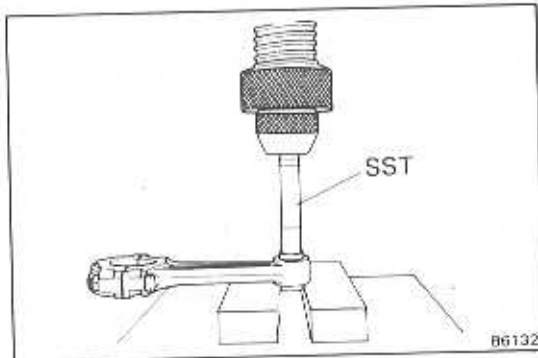
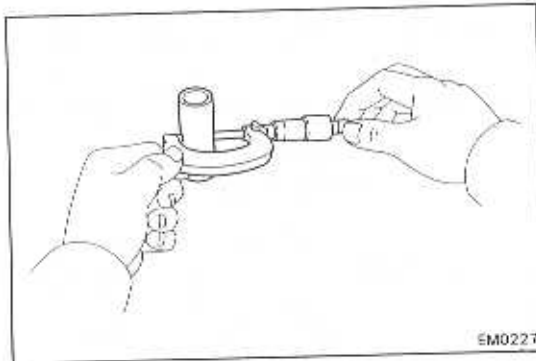
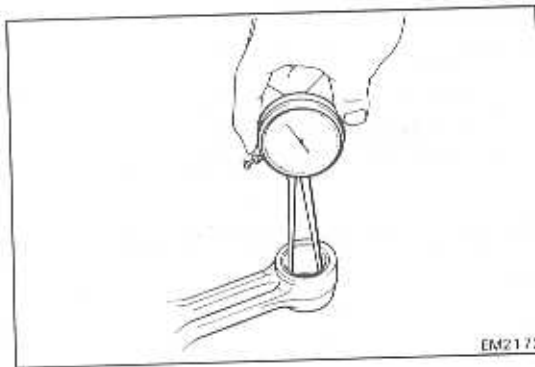

- (b) Measure the oil clearance between the rod bushing and piston pin.

- Using an inside dial indicator, measure the inside diameter of the rod bushing.

- Using a micrometer, measure the diameter of the piston pin.

- Subtract the piston pin diameter from the rod bushing inside diameter.

Standard oil clearance: 0.004 – 0.012 mm
(0.0002 – 0.0005 in.)

Maximum oil clearance: 0.05 mm (0.0020 in.)

If the oil clearance is greater than maximum, replace the rod bushing.

REPLACEMENT OF CONNECTING ROD BUSHING

1. REMOVE ROD BUSHING

- Using SST and a press, press out the bushing.
SST 09222-40011

2. INSTALL NEW ROD BUSHING

- (a) Align the oil holes of the bushing and connecting rod.
(b) Using SST and a press, press in the bushing.
SST 09222-40011

3. HONE ROD BUSHING AND CHECK PISTON PIN FIT IN CONNECTING ROD

- (a) Using a pin hole grinder, hone the bushing and check that the oil clearance is within standard specification.

Standard oil clearance: 0.004 – 0.012 mm
(0.0002 – 0.0005 in.)

- (b) Check the piston pin fit at normal room temperature. Coat the piston pin with engine oil and push it into the rod with your thumb.

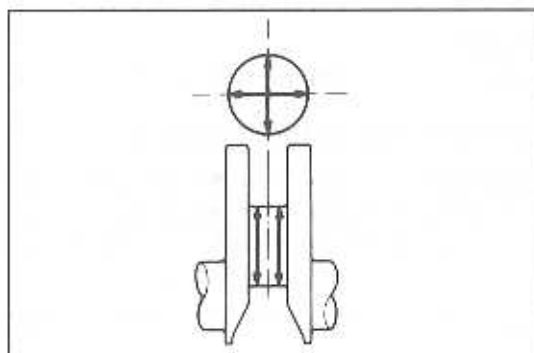
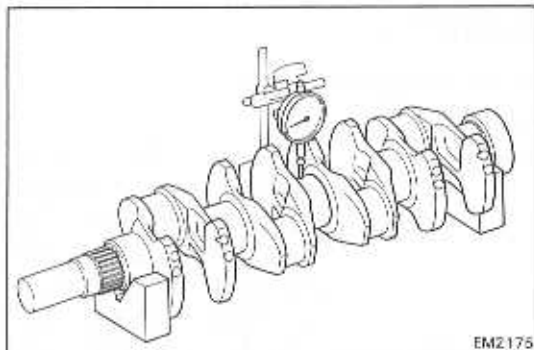

INSPECTION AND REPAIR OF CRANKSHAFT

1. INSPECT CRANKSHAFT

- (a) Place the crankshaft on V-blocks.
- (b) Using a dial indicator, measure the circle runout at the center journal.

Maximum circle runout: 0.1 mm (0.039 in.)

If the circle runout is greater than maximum, replace the crankshaft.

- (c) Using a micrometer, measure the diameter of the main journal and crank pin.

Standard diameter (Standard sized bearing):

Main journal	61.985 – 62.000 mm (2.4403 – 2.4409 in.)
Crank pin	L, 2L 52.988 – 53.000 mm (2.0861 – 2.0866 in.)
	2L-T 54.988 – 55.000 mm (2.1649 – 2.1654 in.)

- (d) Check the main journal and crank pin for taper and out-of-round as shown.

**Maximum taper and out-of-round:
0.02 mm (0.0008 in.)**

If the oil clearance even when new bearings are used, is greater than specified, regrind or replace the crankshaft.

2. GRIND AND HONE MAIN JOURNAL AND/OR CRANK PIN

Grind and hone the main journals and/or crank pins to the undersized finished diameter.

Main journal finished diameter:

U/S 0.25	61.735 – 61.750 mm (2.4305 – 2.4311 in.)
U/S 0.50	61.385 – 61.500 mm (2.4167 – 2.4213 in.)

Crank pin finished diameter:

U/S 0.25	L, 2L 52.738 – 52.750 mm (2.0763 – 2.0768 in.)
	2L-T 54.738 – 54.750 mm (2.1550 – 2.1555 in.)
U/S 0.50	L, 2L 52.488 – 52.500 mm (2.0665 – 2.0669 in.)
	2L-T 54.488 – 54.500 mm (2.1452 – 2.1457 in.)

Install new main journal and/or crank pin undersize bearings.

BORING OF CYLINDERS

1. SELECT PISTON AND PISTON RING

Piston diameter:

Standard size	L	89.955 – 89.985 mm (3.5415 – 3.5427 in.)
	2L, 2L-T	91.940 – 91.970 mm (3.6197 – 3.6209 in.)
Oversize	L	90.455 – 90.485 mm (3.5612 – 3.5624 in.)
	2L, 2L-T	92.440 – 92.470 mm (3.6394 – 3.6405 in.)

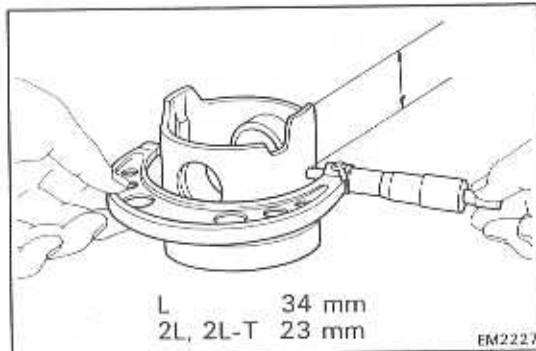

Replace all the pistons.

Replace the piston rings with ones matching the pistons.

2. CALCULATE AMOUNT TO BORE CYLINDER

- Using a micrometer, measure the piston diameter at a right angle to the piston pin hole center line 34 mm (1.34 in.) or 23 mm (0.91 in.) below the skirt bottom edge.
- Calculate the amount each cylinder is to be rebored as follows:

$$\text{Size to be rebored} = P + C - H$$

P = Piston diameter

C = Piston clearance

L 0.035 – 0.055 mm
(0.0014 – 0.0022 in.)

2L, 2L-T 0.050 – 0.070 mm
(0.0020 – 0.0028 in.)

H = Allowance for honing
Less than 0.02 mm (0.0008 in.)

3. BORE AND HONE CYLINDERS TO CALCULATED DIMENSIONS

Maximum honing: 0.02 mm (0.0008 in.)

CAUTION: Excess honing will destroy the finished roundness.

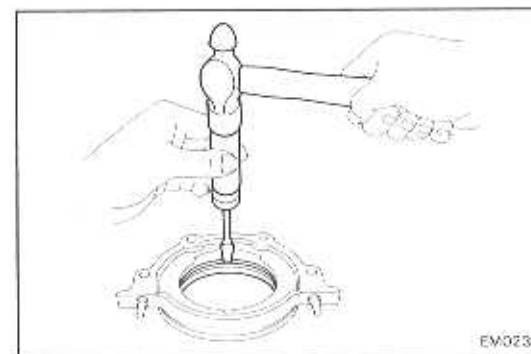
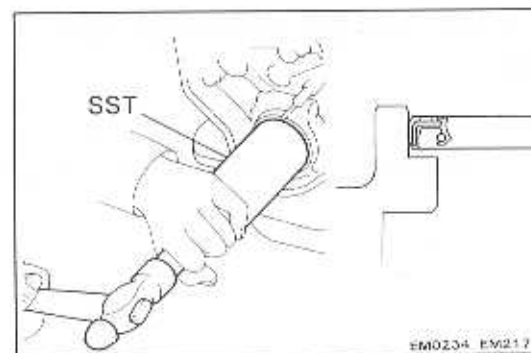
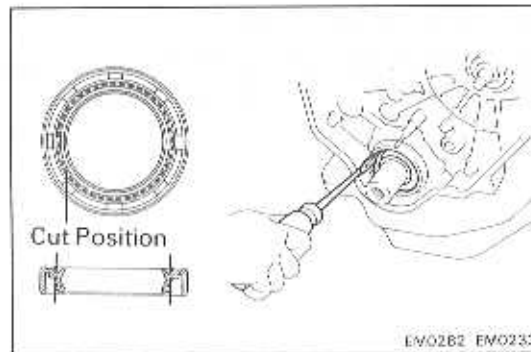
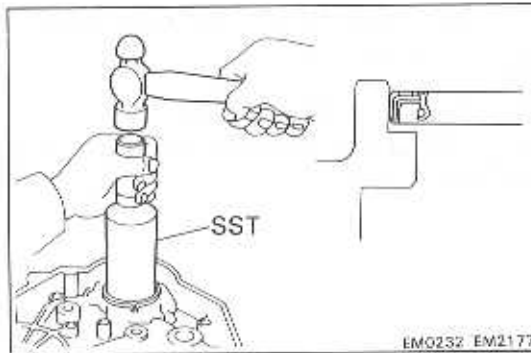
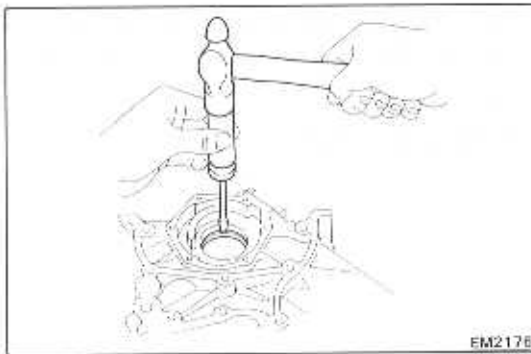

REPLACEMENT OF CRANKSHAFT OIL SEALS

NOTE: There are two methods of oil seal replacement.

1. REPLACE CRANKSHAFT FRONT OIL SEAL

If oil pump body is removed from cylinder block:

- (a) Using a screwdriver and hammer, drive out the oil seal.
 - (b) Using SST and a hammer, drive in a new oil seal to the depth of 0.5 mm (0.020 in.) from the oil pump body edge.
- SST 09214-60010
- (c) Apply MP grease to the oil seal.

If oil pump body is installed to cylinder block:

- (a) Using a knife, cut off the oil seal lip.
- (b) Using a screwdriver, pry out the oil seal.

CAUTION: Be careful not to damage the crankshaft. Tape the screwdriver.

- (c) Apply MP grease to a new oil seal.
 - (d) Using SST and a hammer, drive in the oil seal to a depth of 0.5 mm (0.020 in.) from the oil pump body edge.
- SST 09214-60010

2. REPLACE CRANKSHAFT REAR OIL SEAL

If rear oil seal retainer is removed from cylinder block:

- (a) Using a screwdriver and hammer, drive out the oil seal.

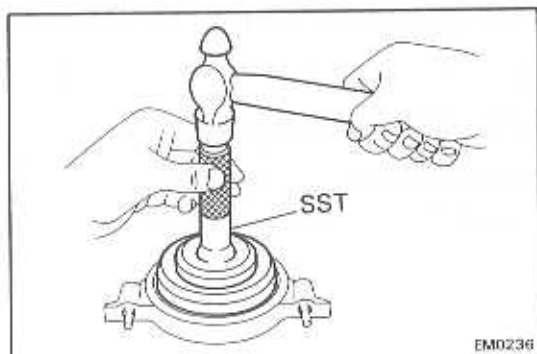

- (b) Using SST and a hammer, drive in a new oil seal until its surface is flush with the rear oil seal retainer edge.

SST 09223-63010

- (c) Apply MP grease to the oil seal.

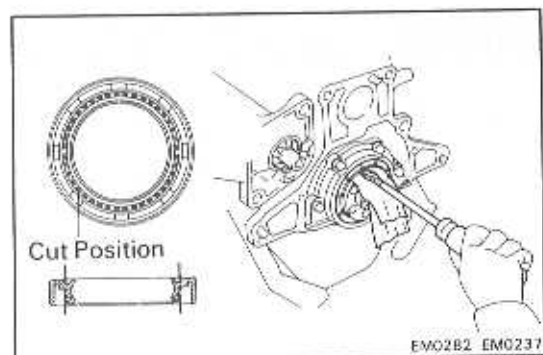

If rear oil seal retainer is installed to cylinder block:

- (a) Using a knife, cut off the oil seal lip.
 (b) Using a screwdriver, pry out the oil seal.

CAUTION: Be careful not to damage the crankshaft. Tape the screwdriver.

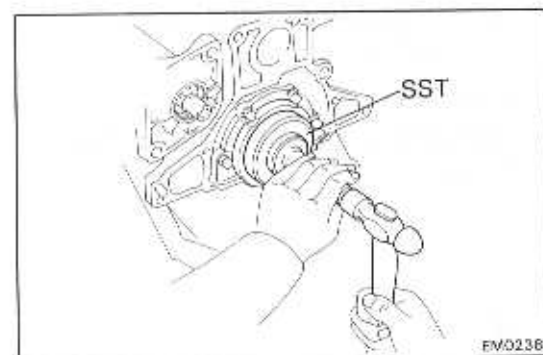

- (c) Apply MP grease to a new oil seal.

- (d) Using SST and a hammer, drive in the oil seal until its surface is flush with the rear oil seal retainer edge.

SST 09223-63010

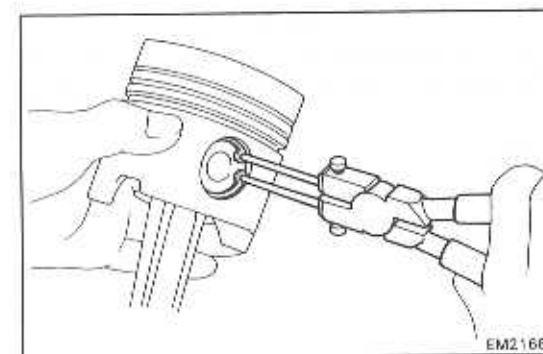

ASSEMBLY OF PISTON AND CONNECTING ROD ASSEMBLY

1. ASSEMBLE PISTON AND CONNECTING ROD

- (a) Install a new snap ring on one side of the piston pin hole.

- (b) Gradually heat the piston to about 60 – 70°C (140 – 158°F).

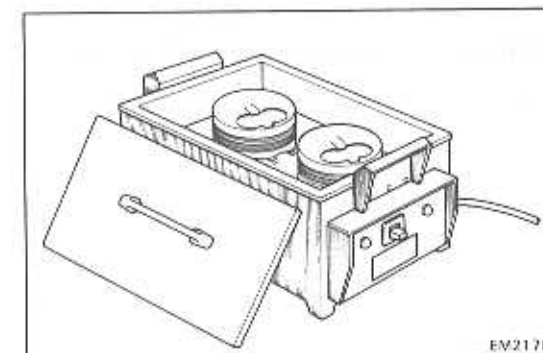

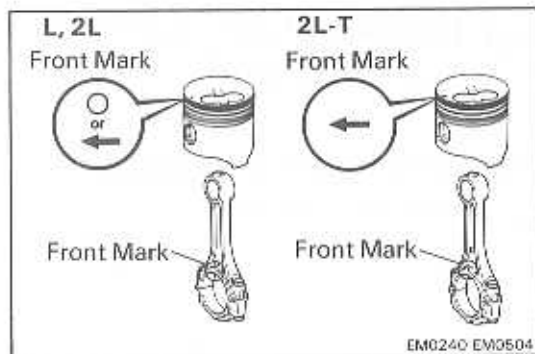

- (c) Align the front marks of the piston and connecting rod, and push in the piston pin with your thumb.
- (d) Install a new snap ring on the other side of the piston pin hole.

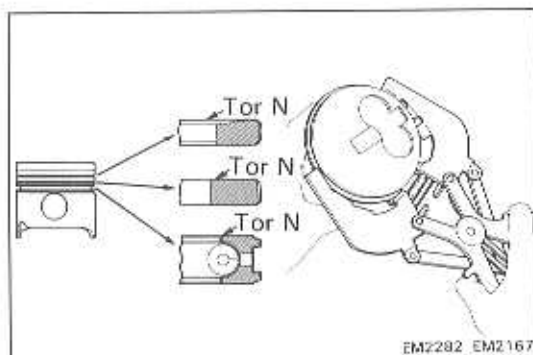

2. INSTALL PISTON RINGS

- (a) Using a ring expander, install the piston rings with the code marks facing upward.

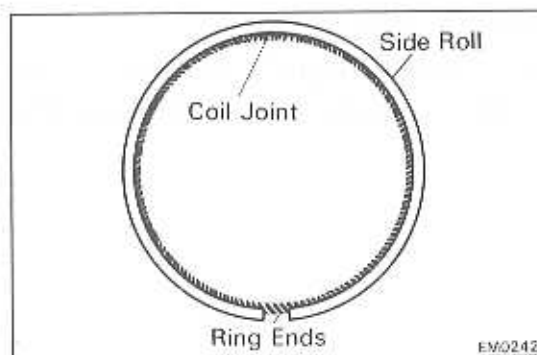

NOTE: When assembling the oil ring and expander coil, insure that the expander coil joint is at the opposite side of the ring ends.

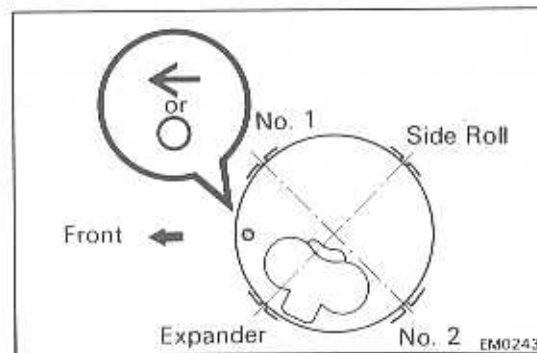

- (b) Position the piston rings so that the ring end gaps are as shown.

CAUTION: Do not align the end gaps.

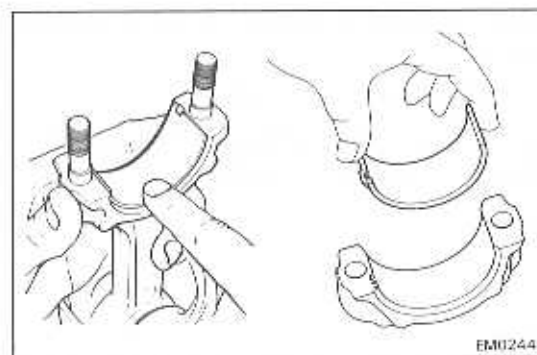

3. INSTALL BEARINGS

Install the bearing inserts in the connecting rods and rod caps.

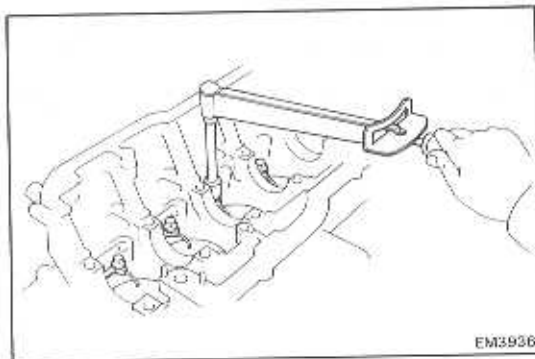

INSTALLATION OF CRANKSHAFT, PISTON AND CONNECTING ROD ASSEMBLY

(See page EM-50)

1. INSTALL OIL JETS AND OIL CHECK VALVES

Torque: 260 kg-cm (19 ft-lb, 25 N·m)

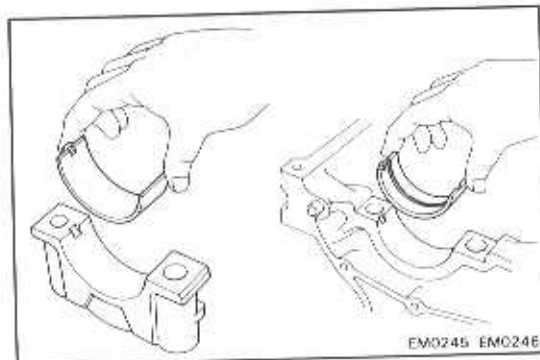
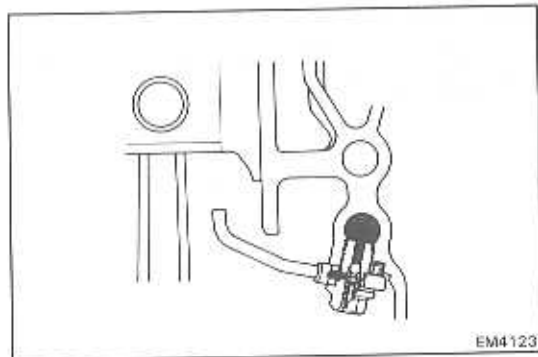

2. INSTALL MAIN BEARINGS

Install the bearing in the cylinder block and bearing caps.

CAUTION: Install the bearing with the oil hole in the block.

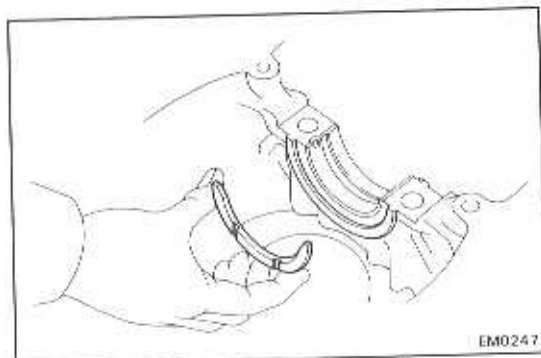

3. INSTALL UPPER THRUST WASHERS

Install the thrust washes under the No. 3 main bearing cap position of the block with the oil grooves facing outward.

4. PLACE CRANKSHAFT ON CYLINDER BLOCK

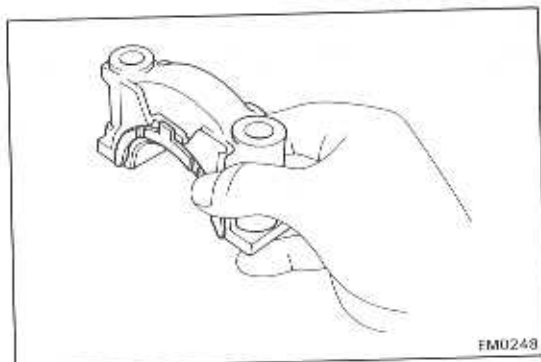

5. INSTALL MAIN BEARING CAPS WITH LOWER THRUST WASHERS

NOTE: Each bearing cap is numbered.

- (a) Install the thrust washers on the No. 3 bearing cap with the oil grooves facing outward.

Ex. No. 3 Bearing Cap No. 3 Bearing Cap

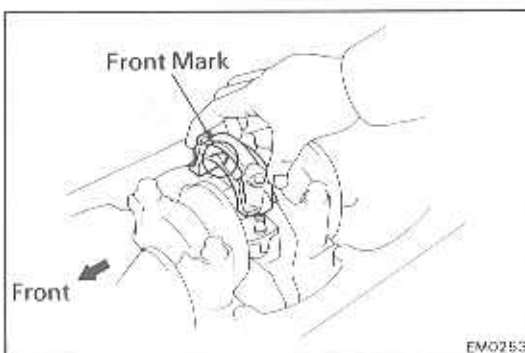
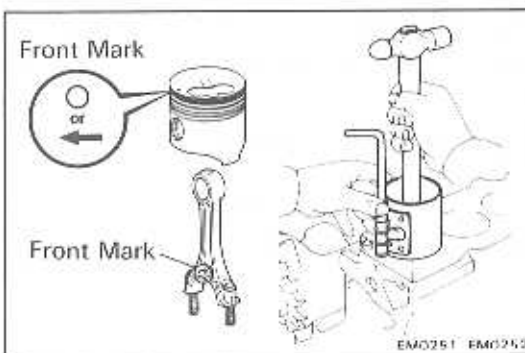
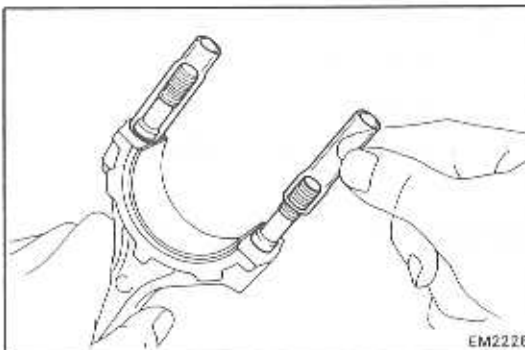
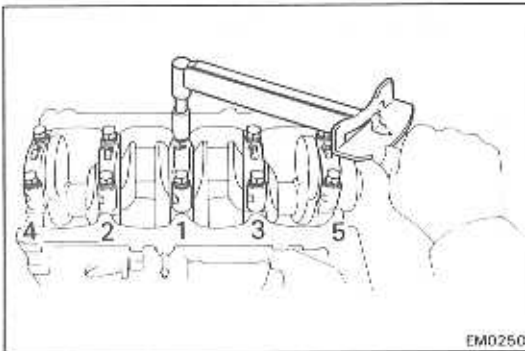
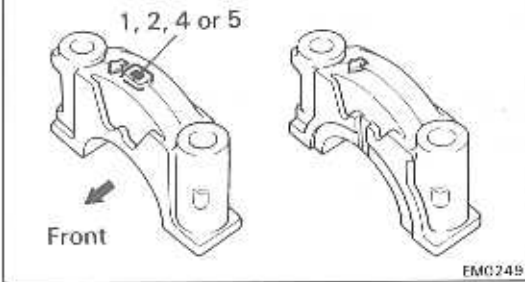

(b) Install the bearing caps in their proper location.

(c) Apply a light coating of engine oil on the threads and heads under of the cap bolts.

(d) Install and tighten the cap bolts in two or three passes and in the sequence shown.

Torque: 1,050 kg-cm (76 ft-lb, 103 N·m)

(e) Check that the crankshaft turns smoothly.

(f) Check the crankshaft thrust clearance.
(See page EM-53)

6. INSTALL PISTON AND CONNECTING ROD ASSEMBLY

(a) Cover the rod bolts with a short piece of hose to protect the crankshaft from damage.

(b) Using a ring compressor, push the correctly numbered piston and rod assembly into each cylinder with the front mark of the piston facing forward.

7. INSTALL CONNECTING ROD CAPS

(a) Match the numbered cap with the numbered rod.

(b) Install the rod caps with the front mark facing forward.

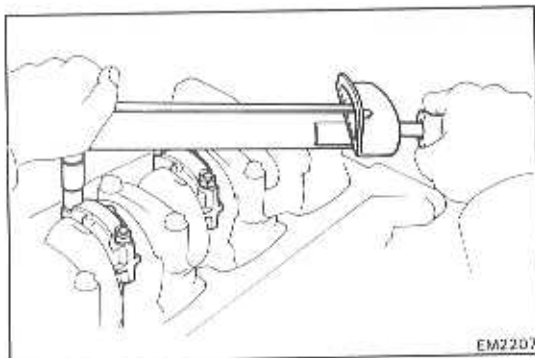

- (c) Apply a light coat of the engine oil on the threads and under the rod nuts.
- (d) Install and tighten the rod nuts alternately in two or three passes.

Torque: 600 kg-cm (43 ft-lb, 59 N·m)

- (e) Check that the crankshaft turns smoothly.
- (f) Check the rod thrust clearance.
(See page EM-51)

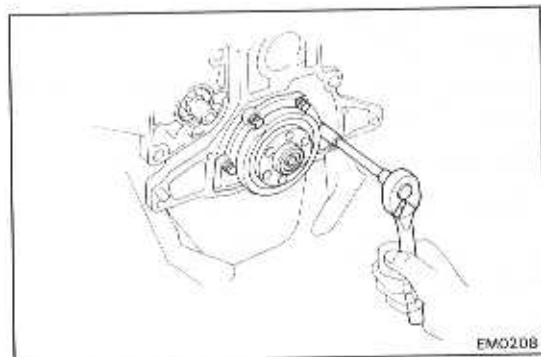

ASSEMBLY OF CYLINDER BLOCK

(See page EM-50)

1. INSTALL REAR OIL SEAL RETAINER

Install a new gasket and the retainer with the four bolts.
Torque the bolts.

Torque: 130 kg-cm (9 ft-lb, 13 N·m)

2. INSTALL OIL PUMP

(See steps 2 to 7 on pages LU-6, 7)

3. INSTALL CYLINDER HEAD

(See steps 1 to 3, 8, 10 to 14 and 16 on pages EM-46 to 49)

4. REMOVE ENGINE STAND

5. INSTALL REAR END PLATE

Install a dust seal and the end plate with the two bolts.
Torque the bolts.

Torque: 120 kg-cm (9 ft-lb, 12 N·m)

6. INSTALL FLYWHEEL OR DRIVE PLATE

Torque: 1,250 kg-cm (90 ft-lb, 123 N·m)

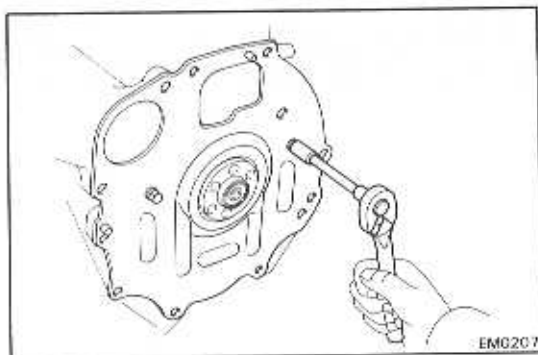

FUEL SYSTEM

	Page
REPLACEMENT OF FUEL FILTER	FU-2
FUEL FILTER WARNING SWITCH	FU-3
FUEL HEATER	FU-5
INJECTION NOZZLES	FU-7
INJECTION PUMP	FU-13

FU

REPLACEMENT OF FUEL FILTER

Standard type

1. REPLACE FUEL FILTER

(a) Using SST, remove the fuel filter and O-ring.
SST 09228-34010

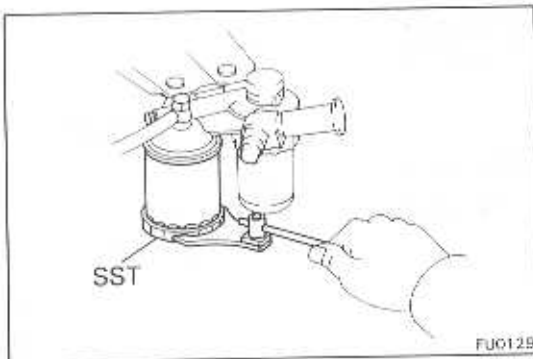

(b) Install a new fuel filter with a new O-ring.

- Put a light coat of fuel on the O-ring.
- Lightly screw in the fuel filter to where you feel resistance.
- Using SST, tighten the fuel filter an extra 3/4 turn.

SST 09228-34010

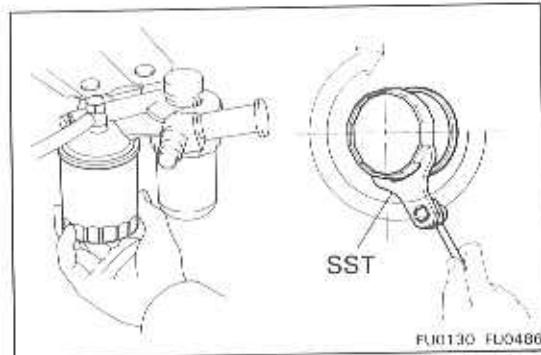

2. FILL FUEL FILTER WITH FUEL

- (a) Turn the hand pump counterclockwise to free it.
 (b) Operate the hand pump until you feel more resistance.
 (c) Turn the hand pump clockwise and tighten it.

3. START ENGINE AND CHECK FOR FUEL LEAKS

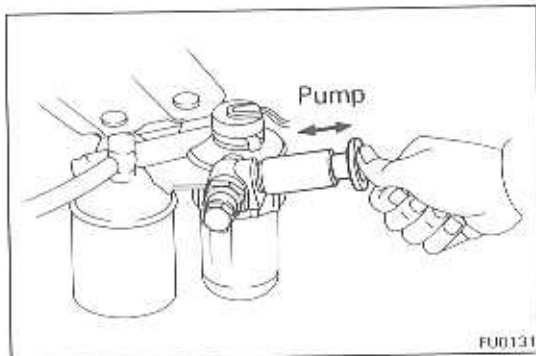

w/ Sedimenter Type

1. REMOVE FUEL FILTER WARNING SWITCH (See steps 1 to 3 on page FU-4)

2. REPLACE FUEL FILTER

(a) Using SST, remove the fuel filter and O-ring.
SST 09228-64010

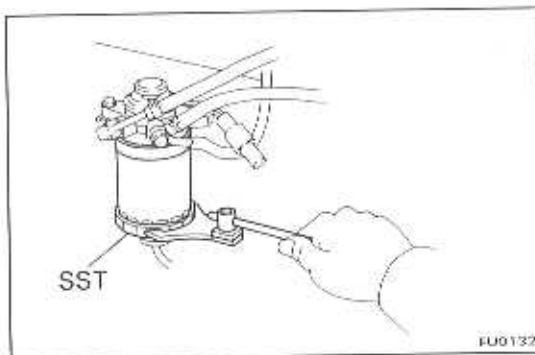

(b) Install the fuel filter with a new O-ring.

- Put a light coat of fuel on the O-ring.
- Lightly screw in the filter to where you feel resistance.
- Using SST, tighten the fuel filter an extra 3/4 turn.

SST 09228-64010

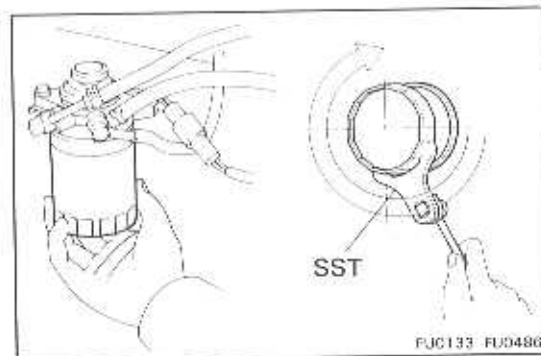

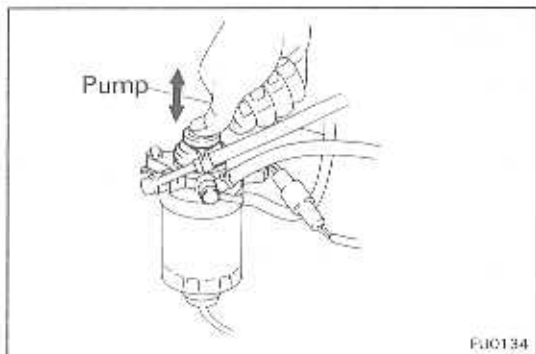

FUC134

3. FILL FUEL FILTER WITH FUEL

Operate the hand pump until you feel more resistance.

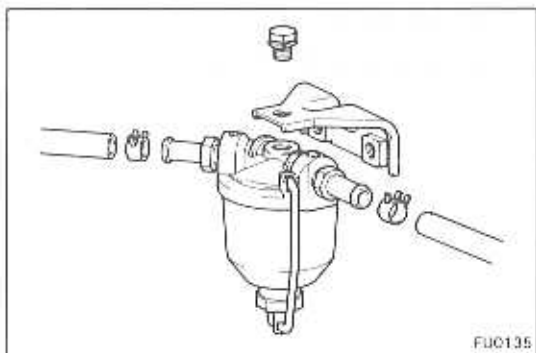

FUC135

FUEL FILTER (LF only)

REPLACE FUEL FILTER

- (a) Disconnect the fuel hoses from the fuel filter.
- (b) Remove the bolt and fuel filter.
- (c) Install a new filter with the bolt.
- (d) Connect the fuel hoses.

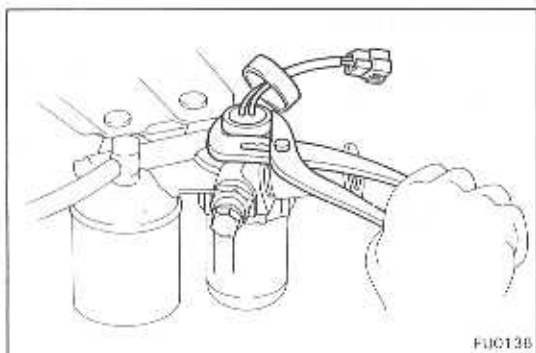

FUC136

FUEL FILTER WARNING SWITCH

INSPECTION OF FUEL FILTER WARNING SWITCH

Standard Type

1. **DISCONNECT WARNING SWITCH CONNECTOR**
2. **REMOVE WARNING SWITCH**

Using pliers, remove the warning switch and gasket.

3. **INSPECT WARNING SWITCH**

- (a) Check that there is continuity between terminals when the warning switch is ON (float up).
- (b) Check that there is no continuity between terminals when the warning switch is OFF (float down).

If operation is not as specified, replace the warning switch.

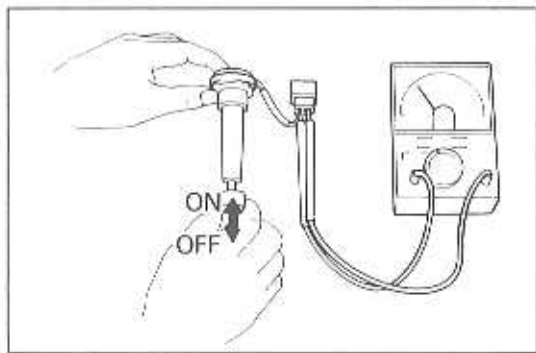

4. **INSTALL WARNING SWITCH**

Install the warning switch with a new gasket.

- Put a light coat of fuel on the gasket.
- Hand tighten ONLY. DO NOT use pliers to tighten the filter.

5. **CONNECT WARNING SWITCH**

6. **START ENGINE AND CHECK FOR FUEL LEAKS**

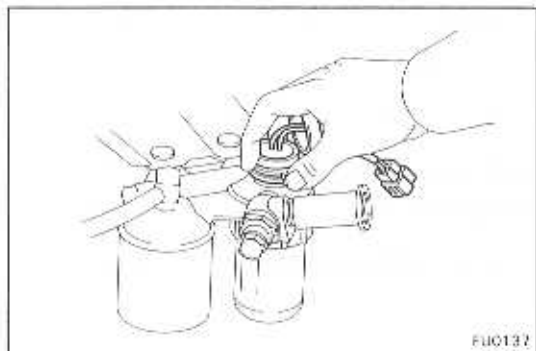

FUC137

w/ Sedimenter Type**1. DRAIN FUEL FROM FILTER**

Remove the drain plug and drain the fuel.

NOTE: Put a suitable container or shop towel under the filter.

2. DISCONNECT WARNING SWITCH CONNECTOR**3. REMOVE WARNING SWITCH**

Using pliers, remove the warning switch and gasket.

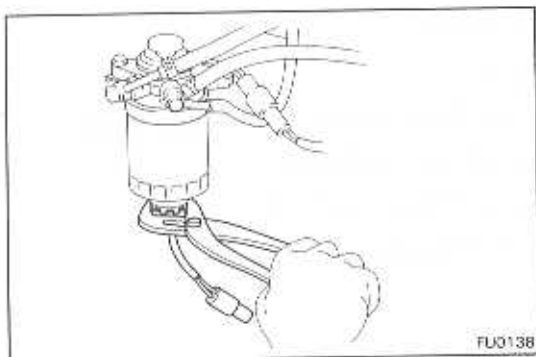
**4. INSPECT WARNING SWITCH**

(a) Check that there is continuity between the terminals when the warning switch is ON (float up).

(b) Check that there is no continuity between the terminals when the warning switch is OFF (float down).

If operation is not as specified, replace the warning switch.

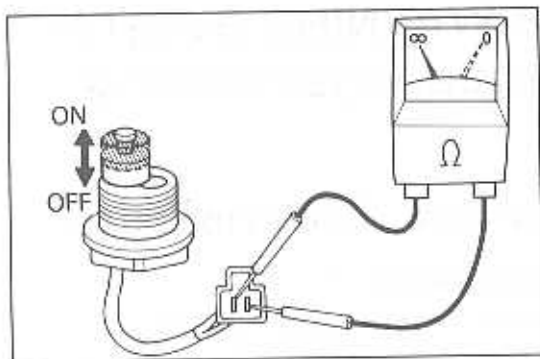
**5. INSTALL WARNING SWITCH**

Install the warning switch with a new gasket

- Put a little fuel on the gasket.
- Hand tighten ONLY. DO NOT use pliers to tighten the filter.

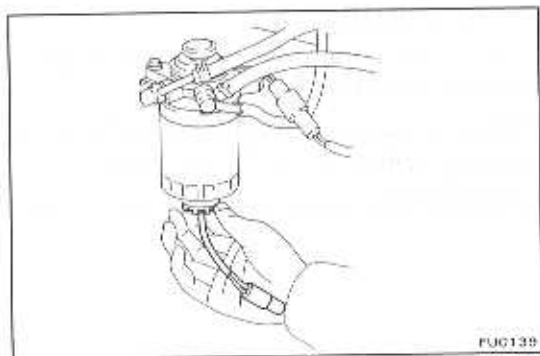
**6. CONNECT WARNING SWITCH CONNECTOR****7. INSTALL DRAIN PLUG**

Install the drain plug with a new gasket.

8. FILL FUEL FILTER WITH FUEL
(See step 3 on page FU-3)**9. START ENGINE AND CHECK FOR FUEL LEAKS**

FUEL HEATER SYSTEM CIRCUIT

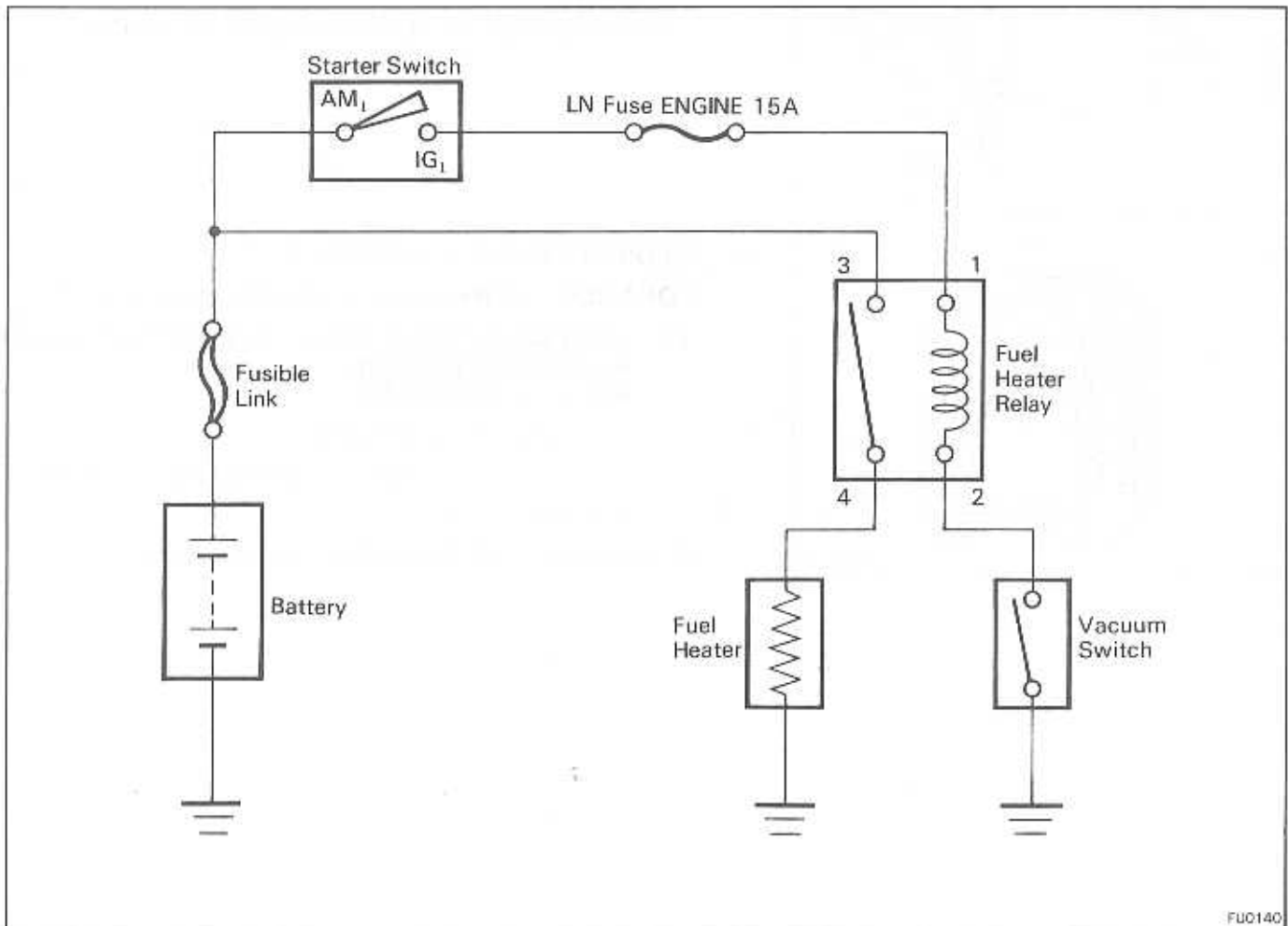

FU0140

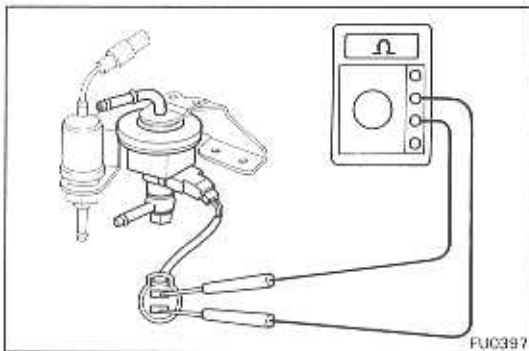

FU0397

INSPECTION OF FUEL HEATER

1. INSPECT FUEL HEATER

Using an ohmmeter, measure the resistance between the terminals.

Resistance: $0.73 \pm 0.29 \Omega$ at 20°C (68°F)

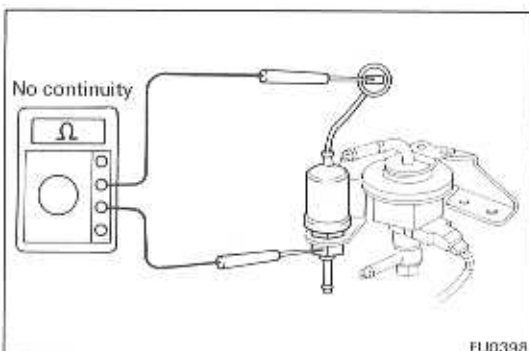

FU0398

2. INSPECT VACUUM SWITCH

- (a) Using an ohmmeter, check that there is no continuity between the switch terminal and switch body.

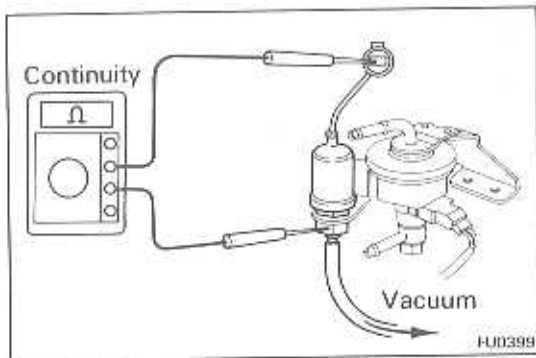

- (b) With a vacuum of 200 ± 60 mmHg (7.87 ± 2.36 in.Hg, 26.7 ± 8.0 kPa) or above, check that there is continuity between the switch terminal and switch body.

If continuity is not as specified, replace the switch.

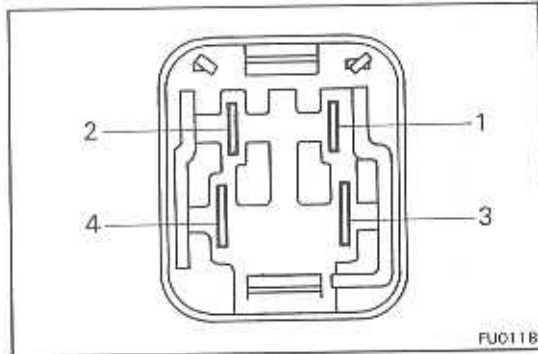

3. INSPECT FUEL HEATER RELAY

LOCATION: In the engine compartment relay box.

- (a) Using an ohmmeter, check for continuity between the following terminals:

- 1 ↔ 2 **Continuity**
- 3 ↔ 4 **No continuity**

- (b) Apply battery voltage between terminals 1 and 2.

- 3 ↔ 4 **Continuity**

If continuity is not as specified, replace relay.

INJECTION NOZZLES

REMOVAL AND TEST OF INJECTION NOZZLES

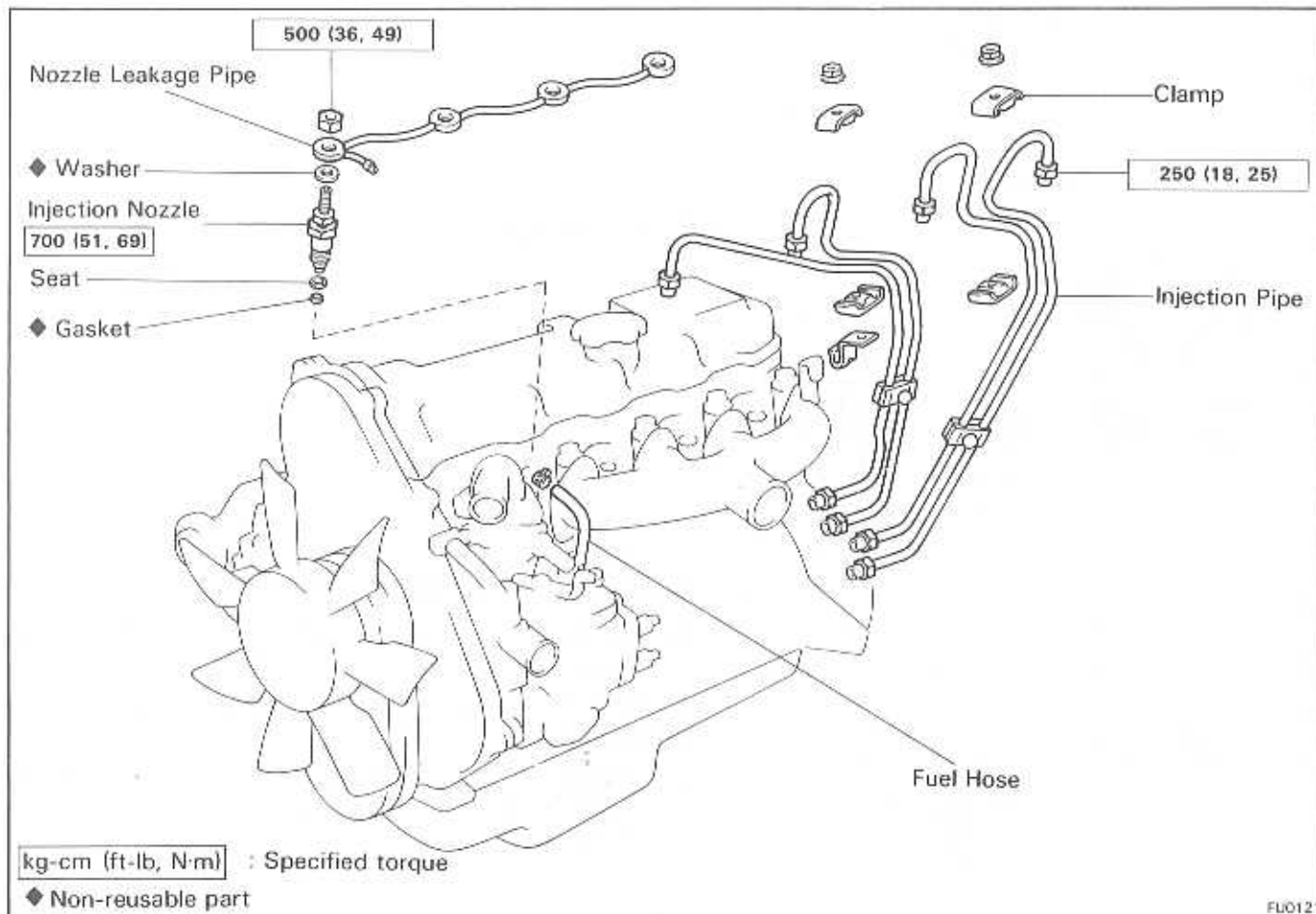

FU0121

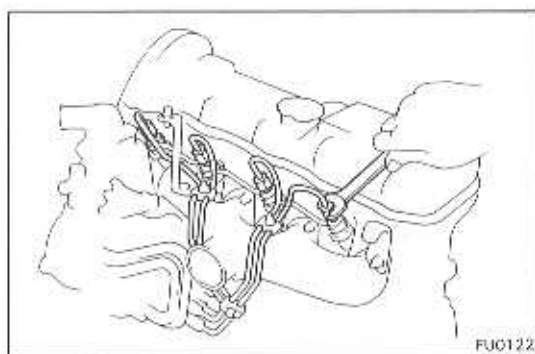

1. REMOVE FOUR INJECTION PIPES

- (a) Remove the two nuts holding the four injection pipes to the intake manifold.
- (b) Remove the four injection pipes and clamps.

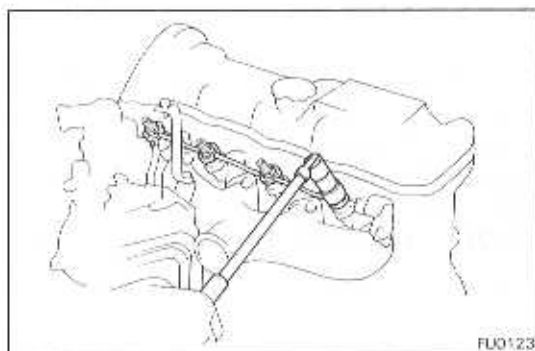

2. REMOVE NOZZLE LEAKAGE PIPE

- (a) Disconnect the fuel hose from the leakage pipe.
- (b) Remove the four nuts, leakage pipe and four washers.

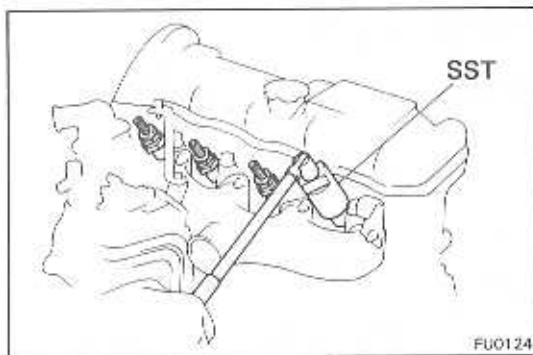

3. REMOVE FOUR INJECTION NOZZLES

Using SST, remove the four nozzles, seats and gaskets.
SST 09260-46012

NOTE: Arrange the nozzles in order.

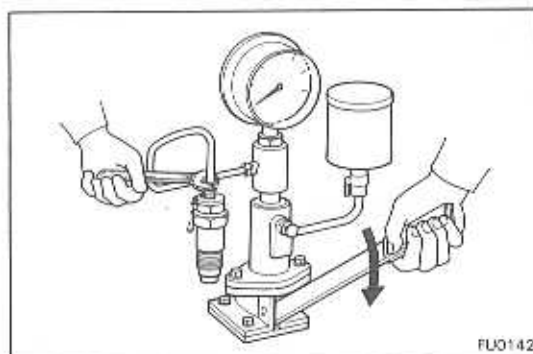
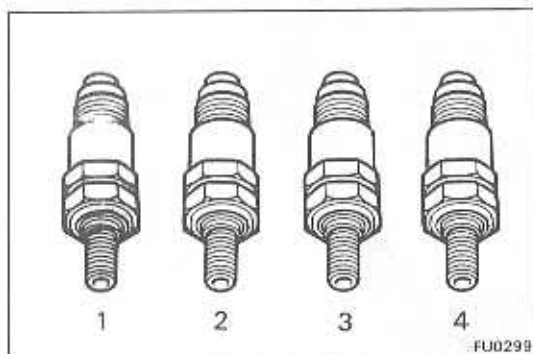

4. INJECTION PRESSURE TEST

- (a) Install the nozzle to an injection nozzle hand tester and bleed the air from the union nut.

WARNING: Do not place your finger over the nozzle injection hole.

- (b) Pump the tester handle a few times as fast as possible by hand to discharge the carbon from the injection hole.

- (c) Pump the tester handle slowly and observe the pressure gauge.

- (d) Read the pressure gauge when the injection pressure just begins to drop.

Opening pressure:

Reused nozzle

L, 2L (ex. LS Hong Kong & Singapore), 2L-T

105 – 125 kg/cm²

(1,493 – 1,778 psi, 10,297 – 12,258 kPa)

2L (LS Hong Kong & Singapore)

145 – 168 kg/cm²

(2,062 – 2,389 psi, 14,220 – 16,475 kPa)

New nozzle

L, 2L (ex. LS Hong Kong & Singapore), 2L-T

115 – 125 kg/cm²

(1,636 – 1,778 psi, 11,278 – 12,258 kPa)

2L (LS Hong Kong & Singapore)

160 – 168 kg/cm²

(2,276 – 2,389 psi, 15,691 – 16,475 kPa)

NOTE: Proper nozzle operation can be determined by a swishing sound.

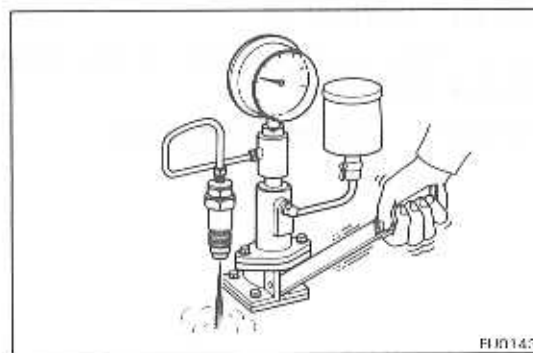

If the opening pressure is not within specification, disassemble the nozzle and change the adjusting shim on the top of the pressure spring.

Adjusted opening pressure:

- L, 2L (ex. LS Hong Kong & Singapore) and 2L-T (A) type
110 – 125 kg/cm²
(1,565 – 1,778 psi, 10,787 – 12,258 kPa)
 - 2L (LS Hong Kong & Singapore) (B) type
160 – 168 kg/cm²
(2,276 – 2,389 psi, 15,691 – 16,475 kPa)
- Adjusting shims mm (in.)

Nozzle type	Shim thickness	Nozzle type	Shim thickness
(B)	0.70 (0.0276)	(A) (B)	1.35 (0.0531)
(B)	0.75 (0.0295)	(A) (B)	1.40 (0.0551)
(B)	0.80 (0.0315)	(A) (B)	1.45 (0.0571)
(B)	0.85 (0.0335)	(A) (B)	1.50 (0.0591)
(B)	0.90 (0.0354)	(A) (B)	1.55 (0.0610)
(B)	0.95 (0.0374)	(A) (B)	1.60 (0.0630)
(A) (B)	1.00 (0.0394)	(A) (B)	1.65 (0.0650)
(A) (B)	1.05 (0.0413)	(A) (B)	1.70 (0.0669)
(A) (B)	1.10 (0.0433)	(A) (B)	1.75 (0.0689)
(A) (B)	1.15 (0.0453)	(A)	1.80 (0.0709)
(A) (B)	1.20 (0.0472)	(A)	1.85 (0.0728)
(A) (B)	1.25 (0.0492)	(A)	1.90 (0.0748)
(A) (B)	1.30 (0.0512)	(A)	1.95 (0.0768)

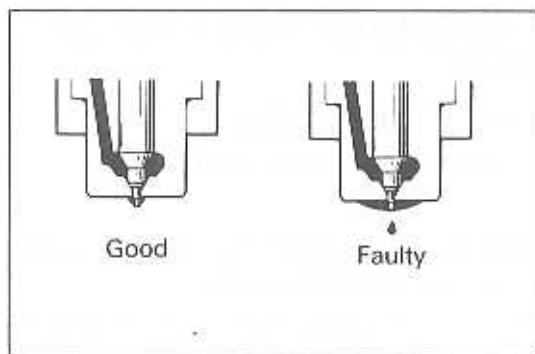
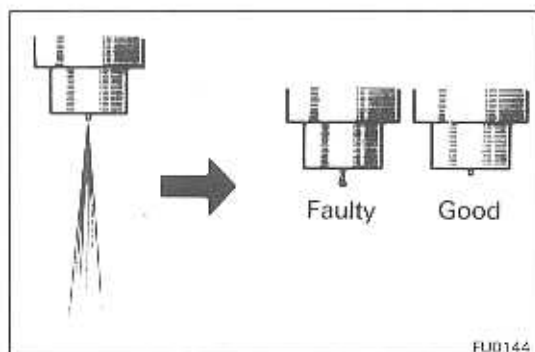

5. LEAKAGE TEST

While maintaining pressure at about 10.0 – 20.0 kg/cm² (142 – 284 psi, 981 – 1,961 kPa) below opening pressure (adjust by tester handle), check that there is no dripping for 10 seconds from the injection hole or around the retaining nut.

If the nozzle drips within 10 seconds, replace it or clean and overhaul the nozzle assembly.

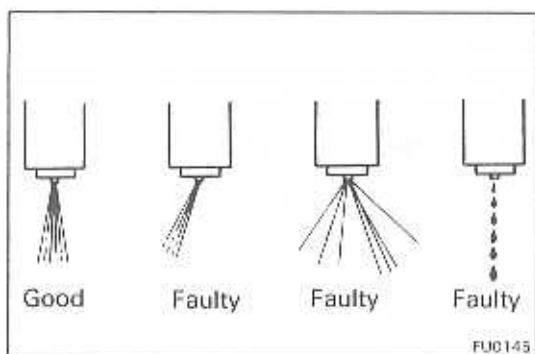

6. SPRAY PATTERN TEST

- (a) The injection nozzle should shudder at a pumping speed between 15 – 60 times (old nozzle) or 30 – 60 times (new nozzle) per minute.
- (b) Check the spray pattern during shuddering.

If the spray pattern is not correct during shuddering, the nozzle must be replaced or cleaned.

COMPONENTS

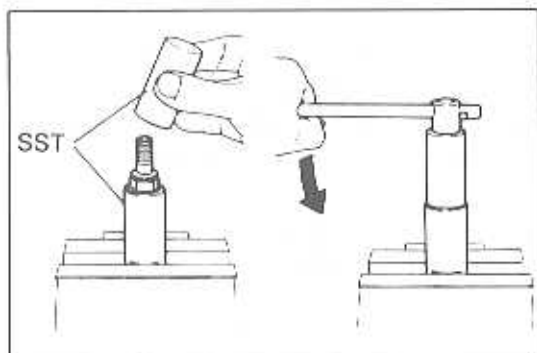
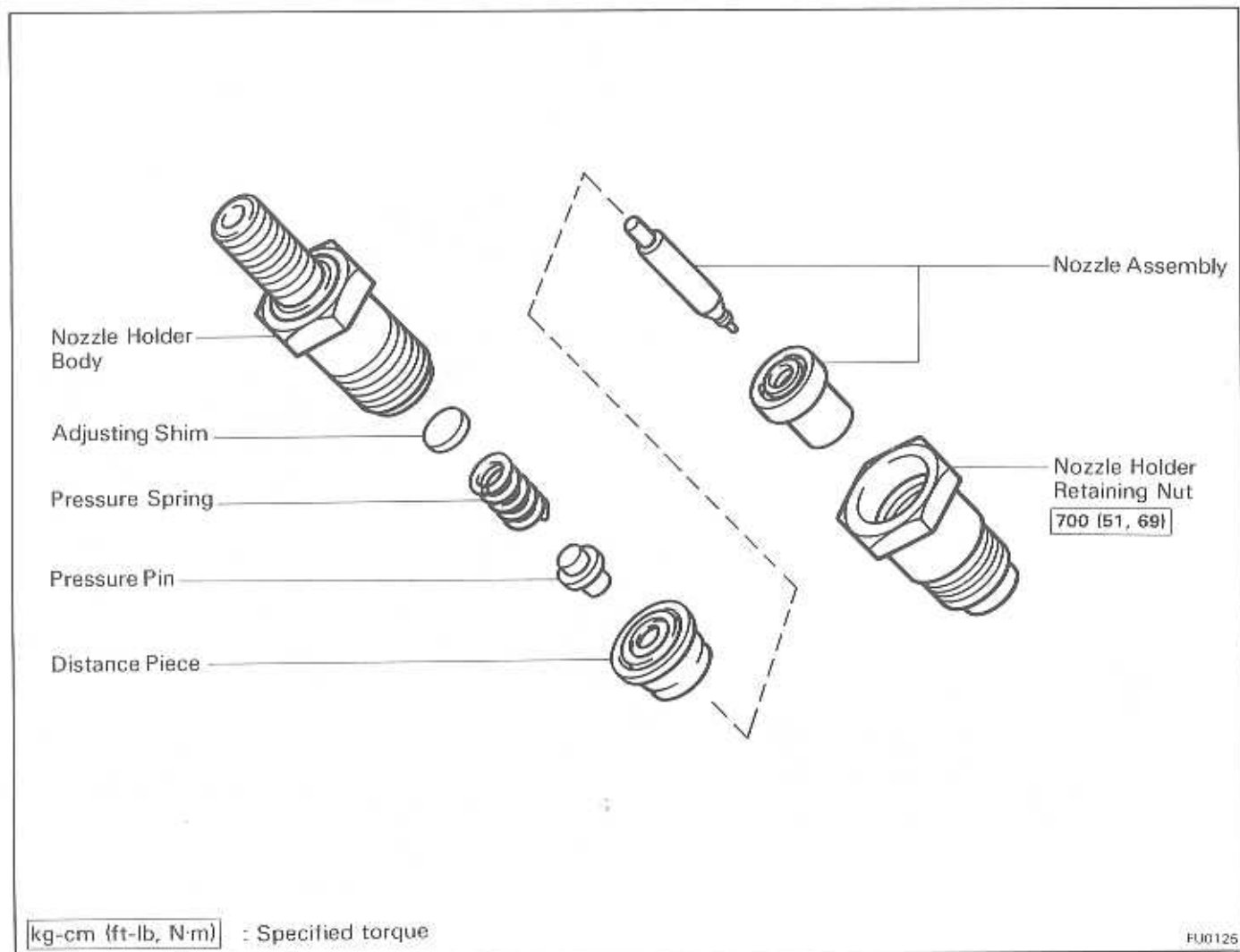

DISASSEMBLY, CLEANING AND TEST OF INJECTION NOZZLE

1. DISASSEMBLE INJECTION NOZZLE

(a) Using SST, unscrew the nozzle holder body.

SST 09260-46012

CAUTION: When disassembling the nozzle holder, be careful not to drop the inner parts.

(b) Remove the pressure spring, shim, pressure pin, distance piece and nozzle assembly.

2. NOZZLE CLEANING

(a) To wash the nozzles, use a wooden stick and brass brush. Wash in clean diesel fuel.

NOTE: Do not touch the nozzle mating surfaces with your fingers.

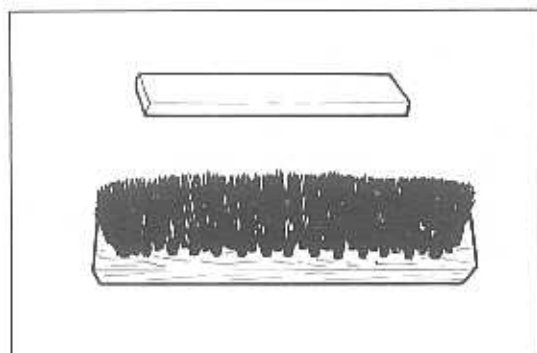

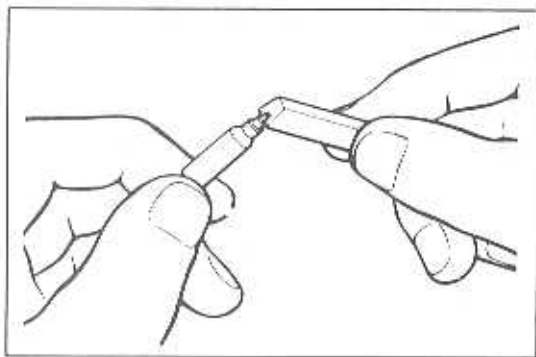

- (b) Remove the carbon adhering to the nozzle needle tip with a wooden stick.

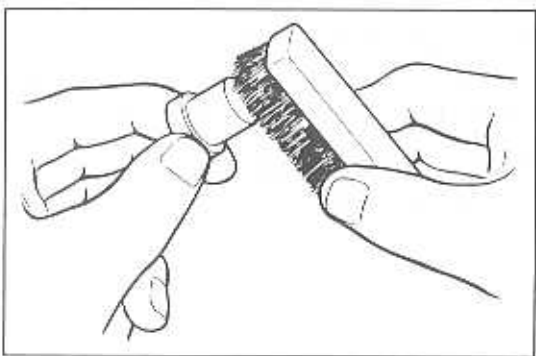

- (c) Remove the carbon from the exterior of the nozzle body with a brass brush.

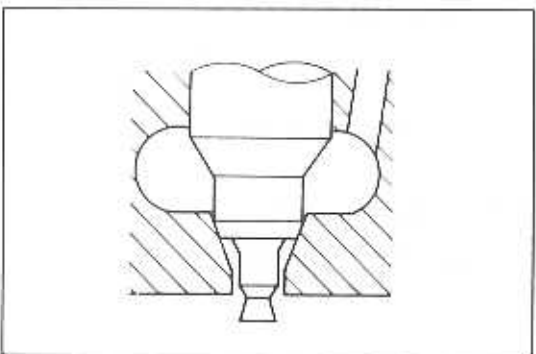

- (d) Inspect the seat of the nozzle body for burns or corrosion.
 (e) Inspect the nozzle needle tip for damage or corrosion.

If any of these conditions are present, replace the nozzle assembly.

3. SINKING TEST

- (a) Wash the nozzle in clean diesel fuel.

NOTE: Do not touch the nozzle mating surfaces with your fingers.

- (b) Tilt the nozzle body about 60 degrees and pull the needle out about one third of its length.

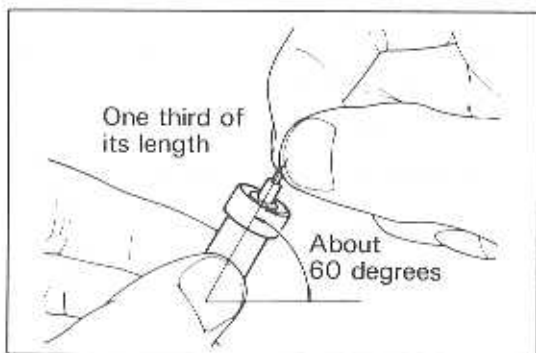

- (c) When released, the needle should sink down into the body vent smoothly by its own weight.
 (d) Repeat this test, rotating the needle slightly each time.

If the needle does not sink freely, replace the nozzle assembly.

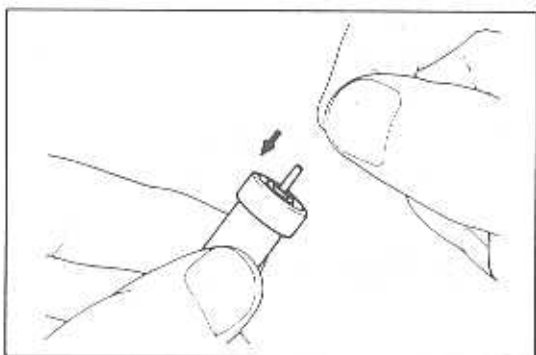

ASSEMBLY AND INSTALLATION OF INJECTION NOZZLE

(See page FU-10)

1. ASSEMBLE INJECTION NOZZLE

(a) Assemble the nozzle holder retaining nut, nozzle assembly, distance piece, pressure pin, pressure spring, adjusting shim and nozzle holder body, and finger tighten the nut.

(b) Using SST, torque the retaining nut.

SST 09260-46012

Torque: 700 kg-cm (51 ft-lb, 69 N·m)

CAUTION: Over torquing could cause nozzle deformation and needle adhesion or other defects.

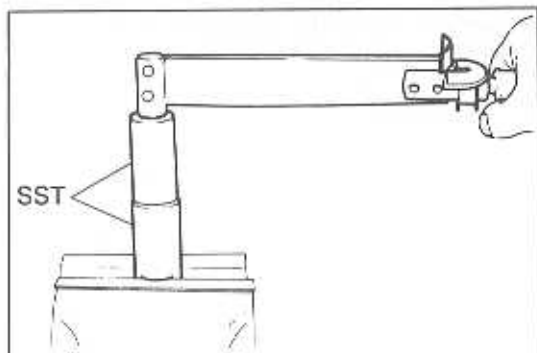

2. PERFORM PRESSURE AND SPRAY PATTERN TEST (See steps 4 to 6 on pages FU-8 and 9)

3. INSTALL FOUR INJECTION NOZZLES

(a) Place four new gaskets and the nozzle seats in the cylinder head.

(b) Using SST, install and torque the four nozzles.

SST 09260-46012

Torque: 700 kg-cm (51 ft-lb, 69 N·m)

CAUTION: Over torquing could cause nozzle deformation and needle adhesion or other defects.

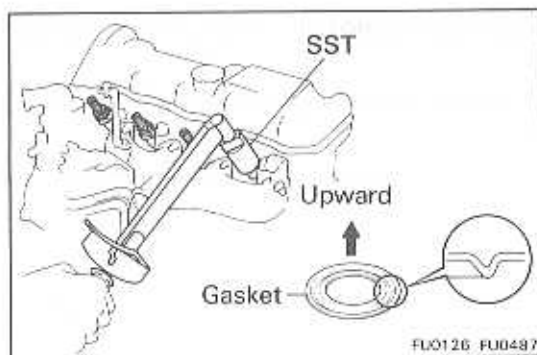

FU0126 FU0487

4. INSTALL NOZZLE LEAKAGE PIPE

(a) Install four new washers and the leakage pipe with the four nuts. Torque the nuts.

Torque: 500 kg-cm (36 ft-lb, 49 N·m)

(b) Connect the fuel hose to the leakage pipe.

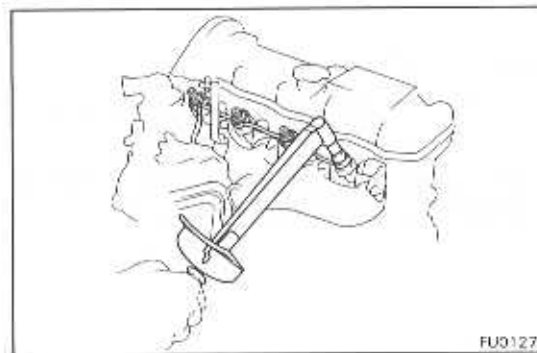

FU0127

5. INSTALL FOUR INJECTION PIPES

(a) Place the two lower clamps in the intake manifold.

(b) Install and torque the four injection pipes.

Torque: 250 kg-cm (18 ft-lb, 25 N·m)

(c) Secure the injection pipes with the two upper clamp and nuts.

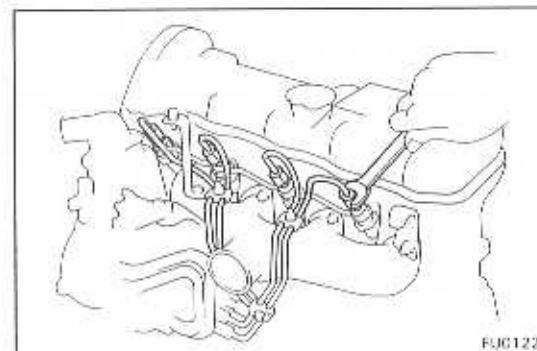

FU0122

6. START ENGINE AND CHECK FOR FUEL LEAKS

INJECTION PUMP

REMOVAL OF INJECTION PUMP

L, 2L (w/o HAC)

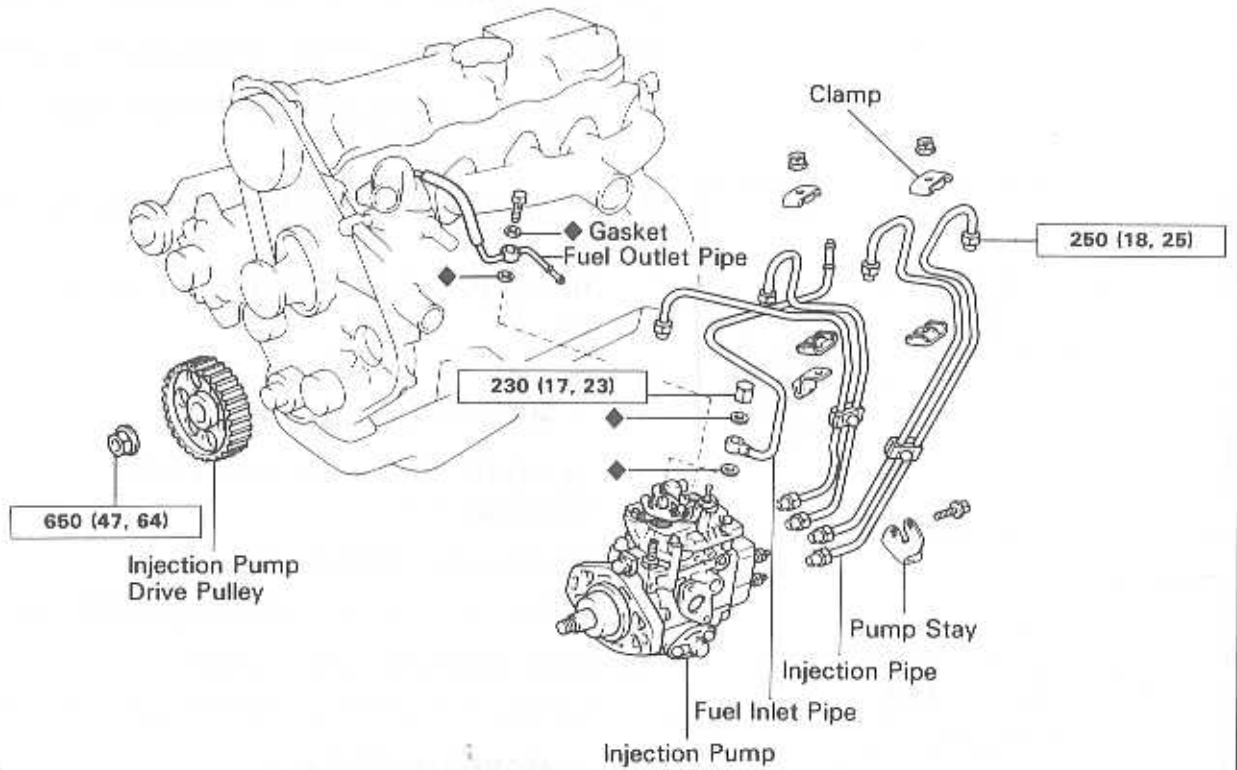

FU0440

L, 2L (w/HAC), 2L-T

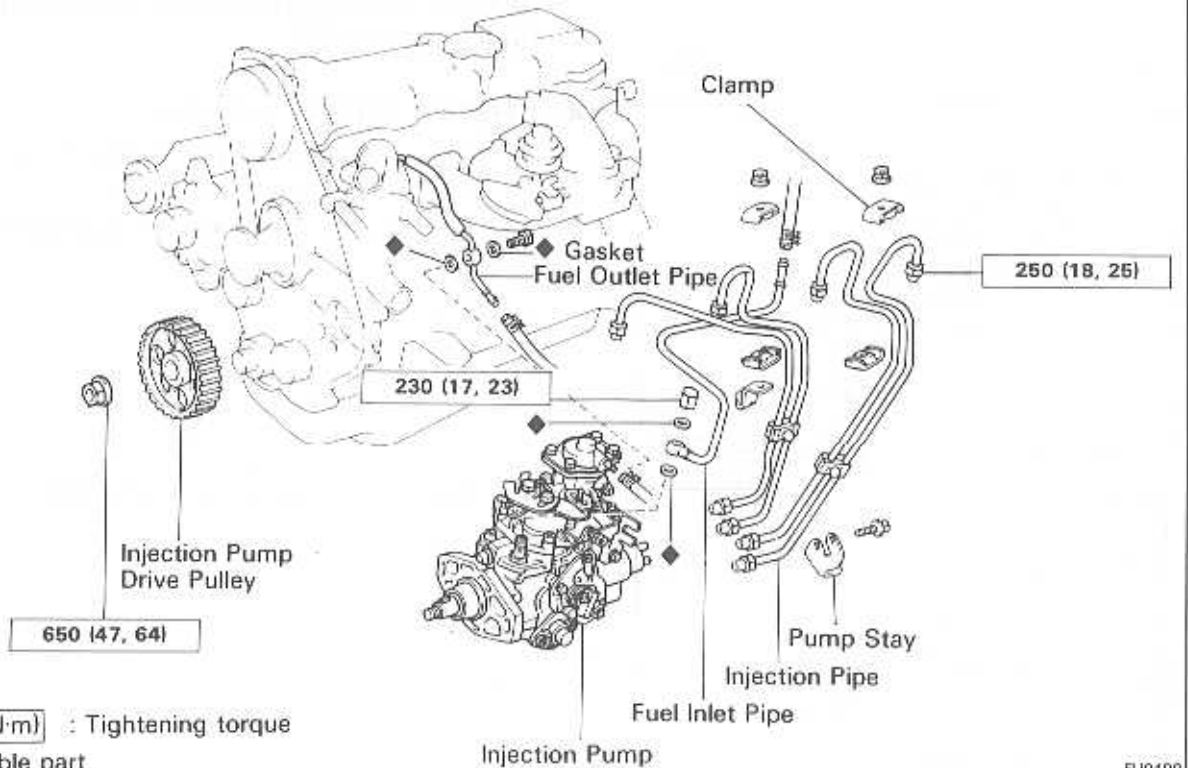

kg-cm (ft-lb, N·m) : Tightening torque

◆ : Non-reusable part

FU0499

1. [LX]
DRAIN COOLANT
2. [2L-T]
DISCONNECT BOOST COMPENSATOR HOSE
3. DISCONNECT FUEL CUT SOLENOID CONNECTOR
4. DISCONNECT PICKUP SENSOR CONNECTOR
5. DISCONNECT FUEL HOSES FROM INLET AND
OUTLET FUEL PIPES

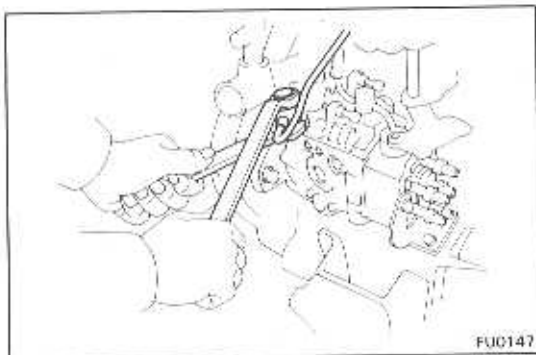

6. REMOVE ACCELERATOR CONNECTING ROD
7. [LX]
DISCONNECT NO. 1 AND NO. 2 WATER BY-PASS
HOSES
8. [2L-T]
REMOVE ACCELERATOR LINK
9. REMOVE FOUR INJECTION PIPES
(See page FU-7)

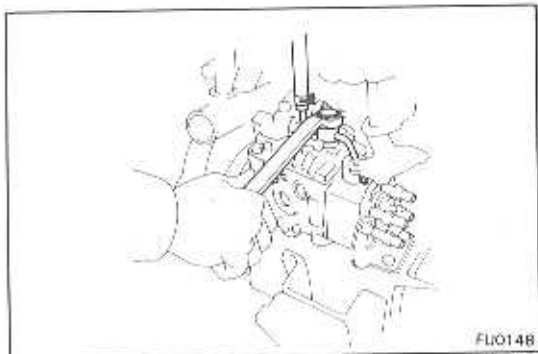

10. REMOVE FUEL INLET PIPE
Remove the union nut, gaskets and inlet pipe.
11. REMOVE FUEL OUTLET PIPE
Remove the union bolt, gaskets and outlet pipe.
12. REMOVE TIMING BELT
(See steps 1 to 8 on pages EM-20 to 22)
13. REMOVE INJECTION PUMP DRIVE PULLEY
(See page EM-23)

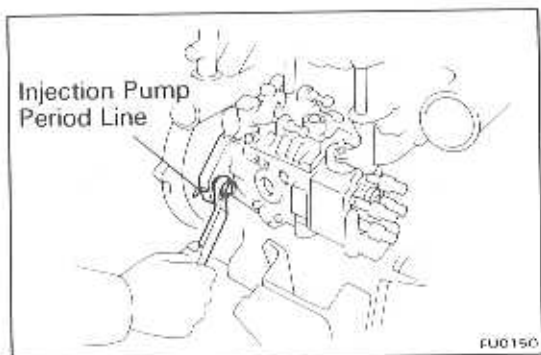

14. REMOVE INJECTION PUMP
 - (a) Check the position of the injection period line before removing the injection pump.
 - (b) Remove the two nuts and injection pump.

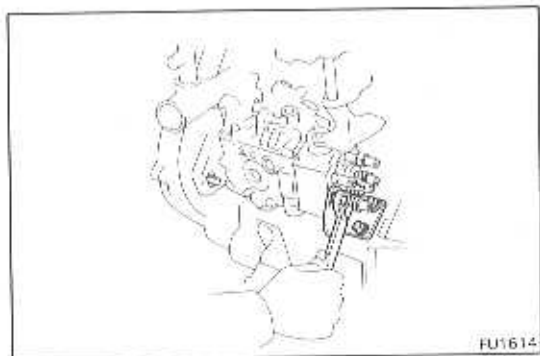

- (c) Remove the four bolts and pump stay.

COMPONENTS

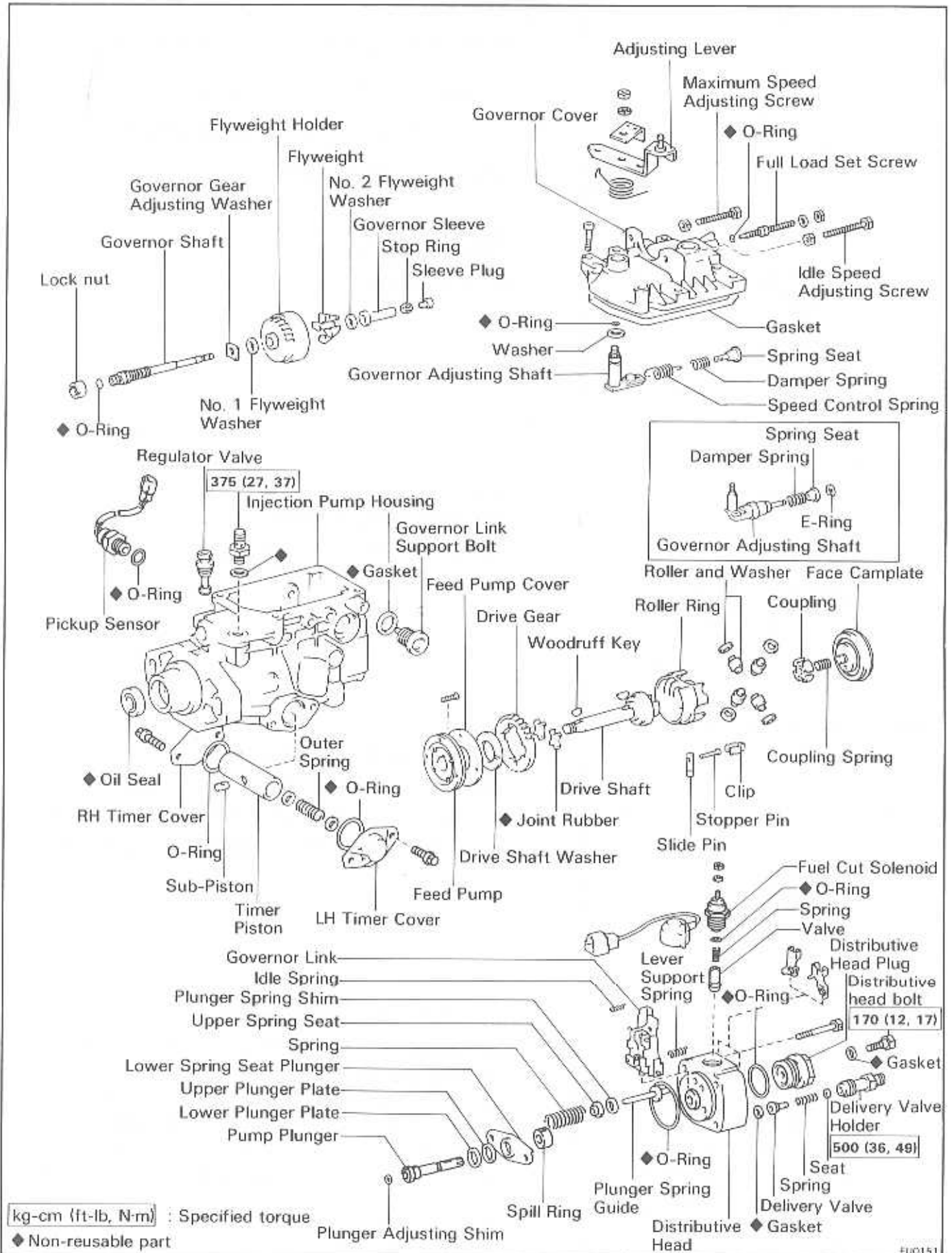

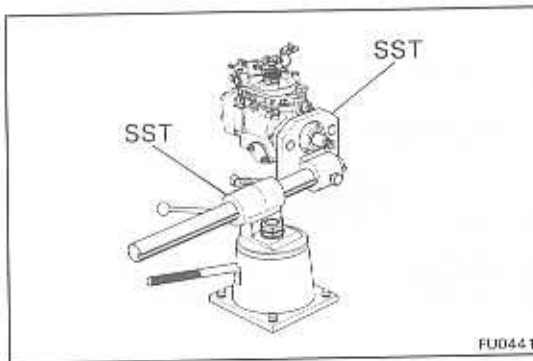

DISASSEMBLY OF INJECTION PUMP

(See page FU-15)

1. MOUNT INJECTION PUMP TO STAND (SST) FOR DISASSEMBLY
SST 09241-76022 and 09245-54010
2. REMOVE WOODRUFF KEY FROM DRIVE SHAFT
3. REMOVE PICKUP SENSOR

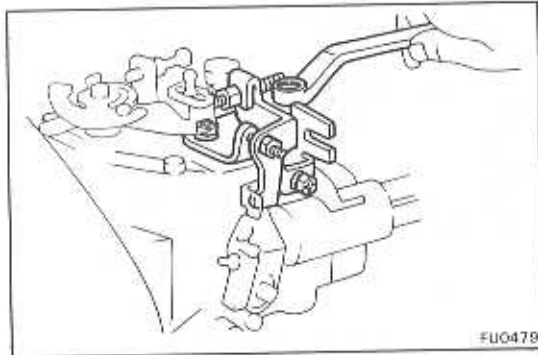

4. [LX]
REMOVE IDLE-UP
Remove the three bolts and idle-up.

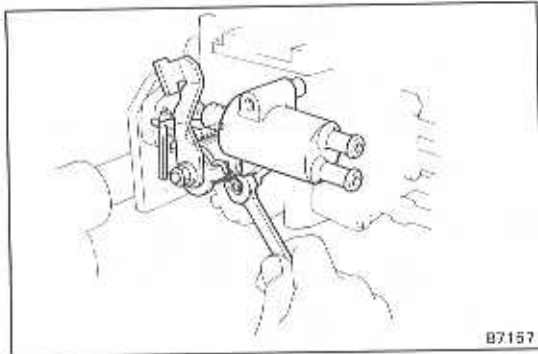

5. [LX]
REMOVE THERMO WAX
Remove the two bolts, thermo wax and O-ring.

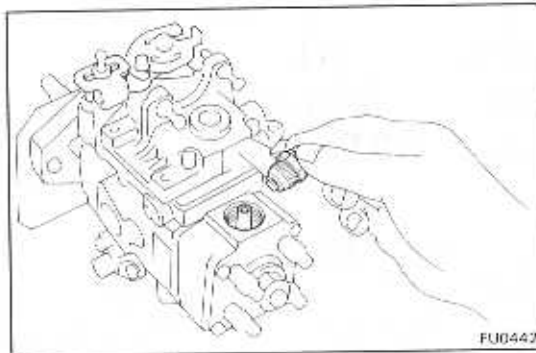

6. REMOVE FUEL CUT SOLENOID
 - (a) Remove the lead wire.
 - (b) Remove the lead wire connector from brackets.
 - (c) Remove the fuel cut solenoid, spring and valve.

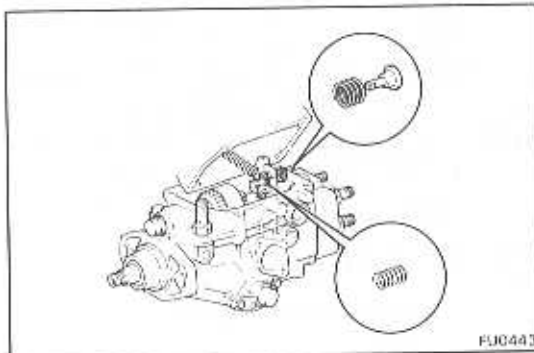

7. REMOVE GOVERNOR COVER
 - (a) Using an allen wrench, remove the four bolts.
 - (b) [M/T (ex. LX)]
Disconnect the speed control spring from the governor spring seat and remove the governor cover, spring seat, damper spring and idle spring.

CAUTION: Be careful not to lose the idle spring.

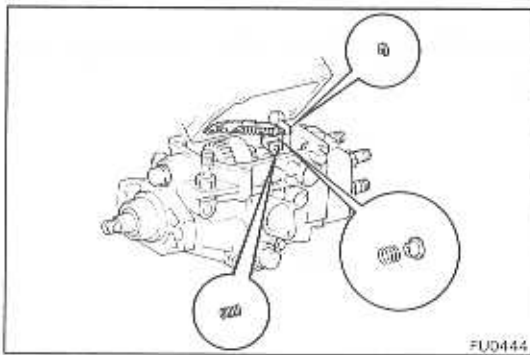

FU0444

[M/T (LX) & A/T]

Remove the E-ring, governor spring seat, damper spring and idle spring.

CAUTION: Be careful not to lose the idle spring.

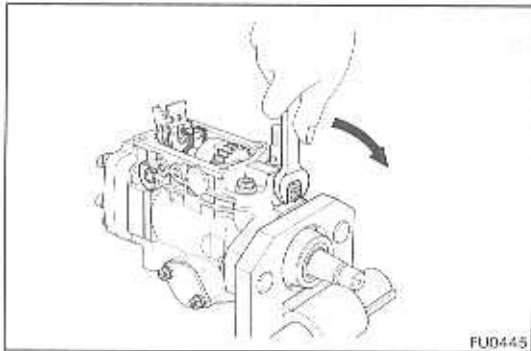

FU0445

8. REMOVE GOVERNOR SHAFT AND FLYWEIGHT HOLDER

(a) Remove the governor shaft lock nut by turning it clockwise.

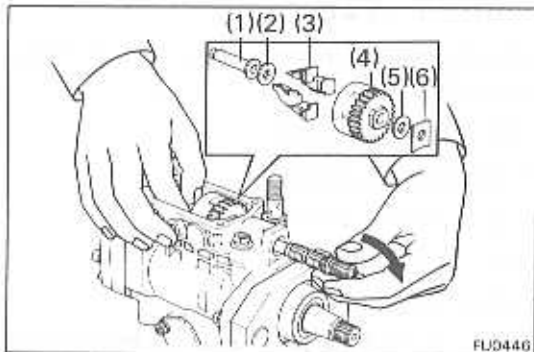

FU0446

(b) Turn the governor shaft clockwise and remove it and the following parts:

- (1) Governor sleeve
- (2) No. 2 flyweight washer
- (3) Four flyweights
- (4) Flyweight holder
- (5) No. 1 flyweight washer
- (6) Governor gear adjusting washer

NOTE: Be careful not to drop the washers into the pump housing.

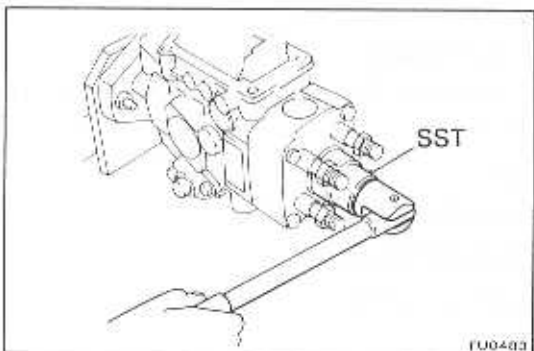

FU0483

9. REMOVE DISTRIBUTIVE HEAD PLUG

Using SST, remove the distributive head plug.
SST 09260-54012

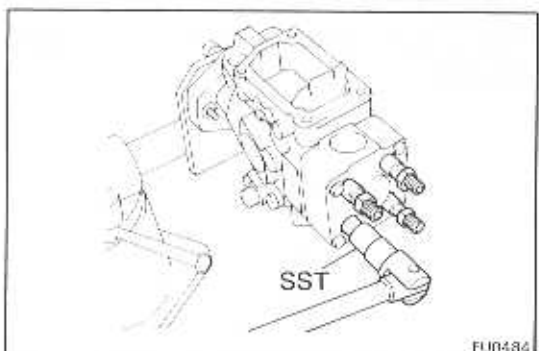

FU0484

10. REMOVE FOUR DELIVERY VALVE HOLDERS

(a) Using SST, remove the four delivery valve holders, springs and seats.

SST 09260-54012

(b) Remove the four delivery valves and gaskets.

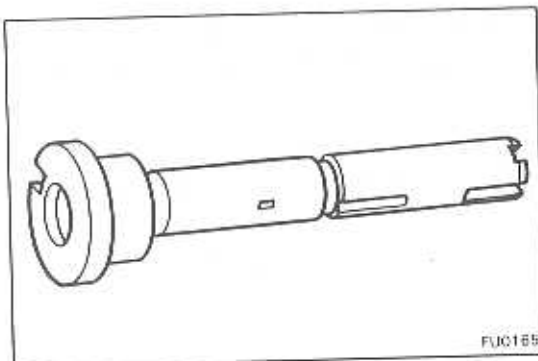
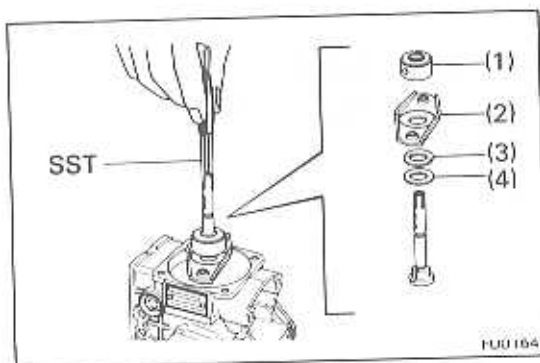
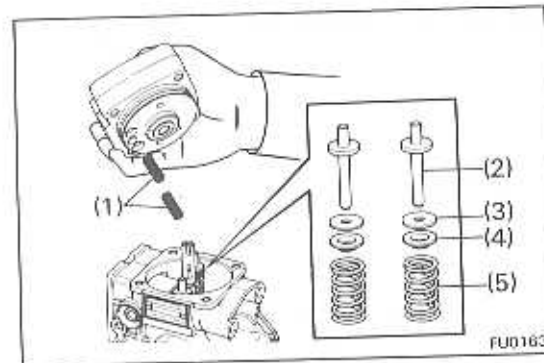
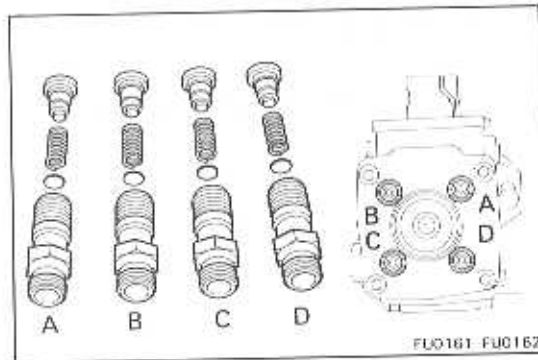
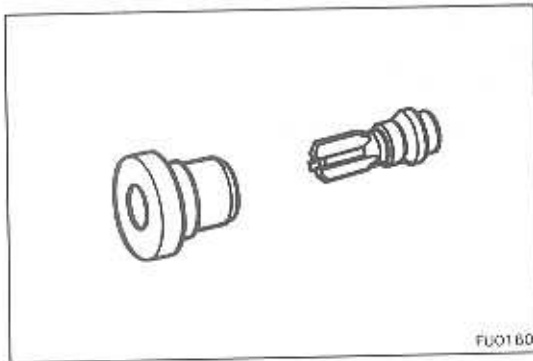
**NOTE:**

- Do not touch the sliding surfaces of the delivery valve with your hand.

- Arrange the delivery valves, springs, spring seats and holders in order.

11. REMOVE DISTRIBUTIVE HEAD

Remove the four bolts, wire connector bracket, distributive head and following parts:

- (1) Two lever support springs
- (2) Two plunger spring guides
- (3) Two plunger spring shims
- (4) Two upper spring seats
- (5) Two plunger springs

CAUTION: Be careful not to lose the lever support spring.

12. REMOVE PUMP PLUNGER

- (a) Using SST, remove the pump plunger with the following parts:

- (1) Spill ring
- (2) Lower spring seat
- (3) Upper plunger plate
- (4) Lower plunger plate

SST 09260-54012

- (b) Remove the plunger adjusting shim.

NOTE: Do not touch the sliding surfaces of the pump plunger with your hand.

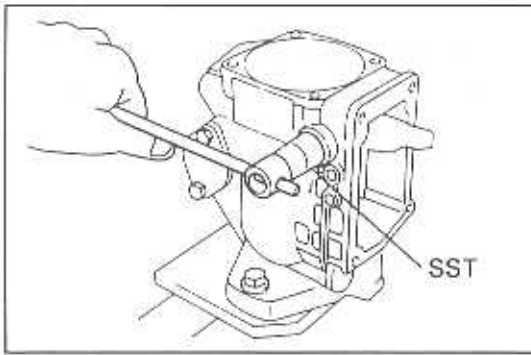
**13. REMOVE GOVERNOR LINK**

Using SST, remove the two governor link support bolts, gasket and governor link.

SST 09260-54012

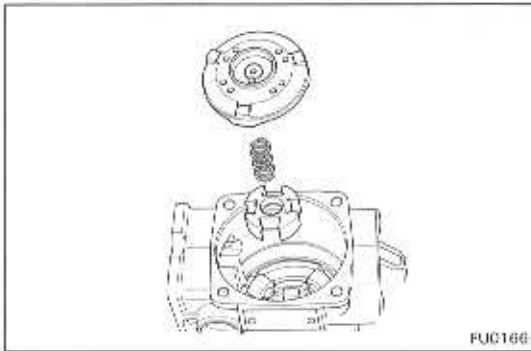
**14. REMOVE FACE CAMPLATE AND COUPLING**

Remove the face camplate, spring and coupling.

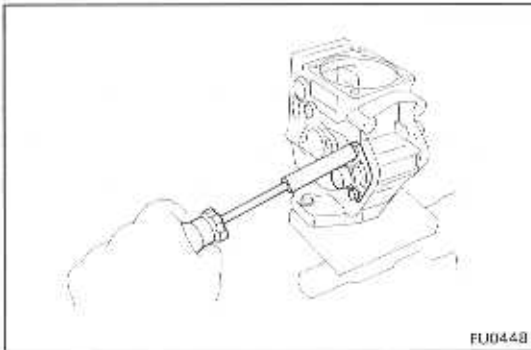
**15. REMOVE ROLLER RING, DRIVE SHAFT AND TIMER**

(a) Remove the two bolts and following parts:

- (1) LH timer cover
- (2) O-ring
- (3) Timer outer spring
- (4) Washer

(b) Remove the timer clip and stopper pin.

(c) Push on the slide pin as shown.

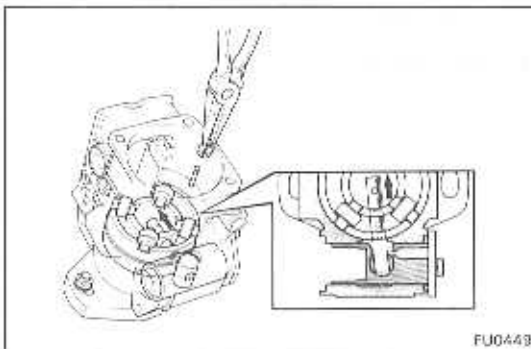

(d) Push out the drive shaft with the roller ring.

(e) Remove the drive shaft washer.

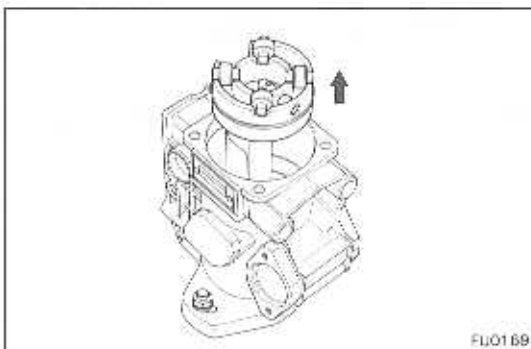

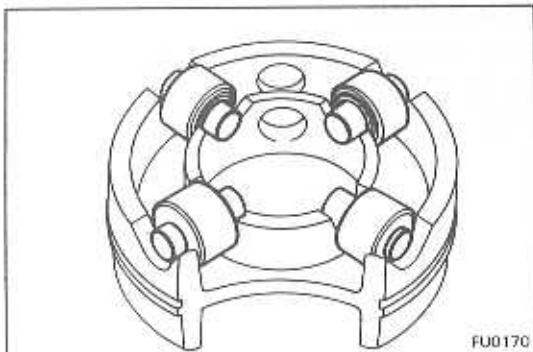

NOTE:

- Be careful not to drop the rollers.
- Do not alter the position or assembly of the rollers.

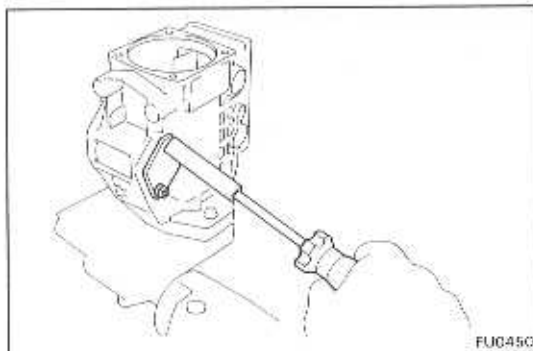

(f) Remove the two bolts and following parts.

- (1) RH timer cover
- (2) O-ring
- (3) Timer piston
- (4) Sub-piston

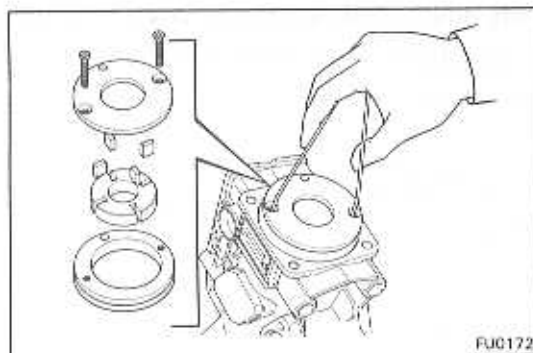
**16. REMOVE FEED PUMP**

- (a) Remove the two screws.
- (b) Using a piece of wire, remove the feed pump cover.
- (c) Remove the feed pump rotor, four blades and liner.

CAUTION: Be careful not to interchange the blade positions.

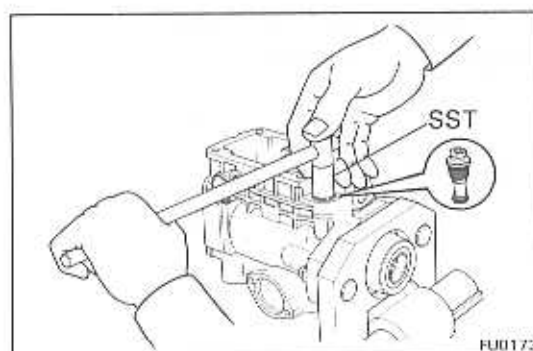
**17. REMOVE REGULATOR VALVE**

Using SST, remove the regulator valve.

SST 09260-54012

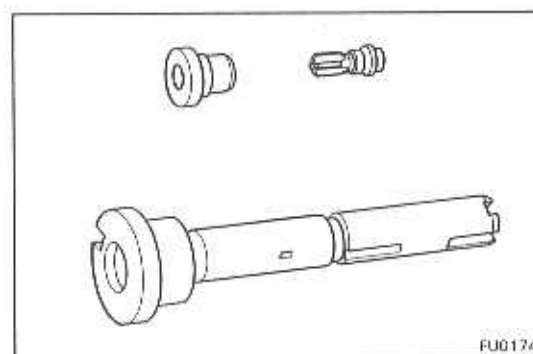
**INSPECTION OF INJECTION PUMP COMPONENTS**

NOTE: Do not touch the sliding surfaces of the pump plunger and delivery valves.

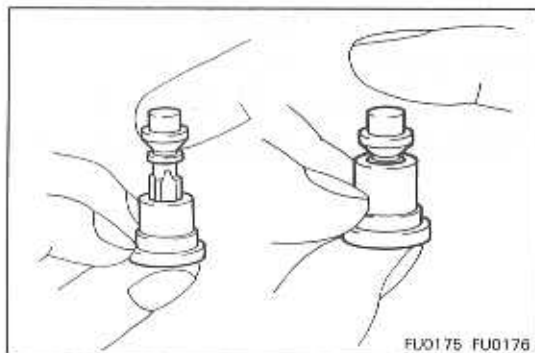

1. INSPECT DELIVERY VALVES

- (a) Pull up the valve and close the hole at the valve seat bottom end with your thumb. When the valve is released, it should sink down quickly and stop at the position where the relief ring closes the valve seat hole.

If defective, replace the valve as a set.

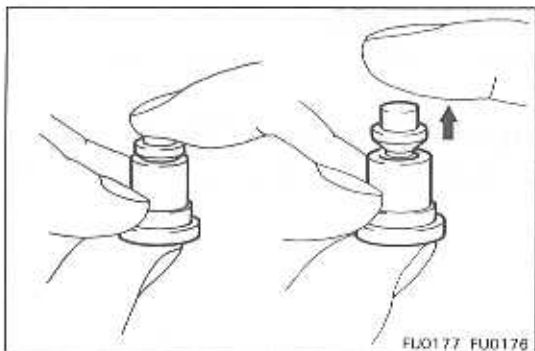

- (b) Close the hole at the valve seat bottom end with your thumb. Insert the valve into the valve seat and press down with your finger. When your finger is released, the valve should rise back to its original position.

Replace if defective.

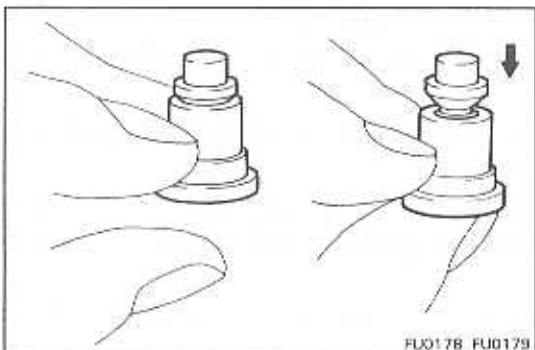

- (c) Remove your thumb from the valve seat hole. The valve should close completely by its own weight.

If defective, replace the valve as a set.

NOTE: Before using a new valve set, wash off the rust prevention compound with light oil or gasoline. Then re-wash with diesel fuel and perform the above tests.

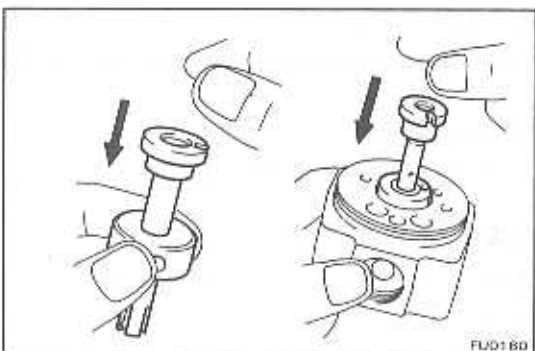

2. INSPECT PUMP PLUNGER, SPILL RING AND DISTRIBUTIVE HEAD

- (a) Tilt the spill ring (distributive head) slightly and pull out the plunger.
 (b) When released, the plunger should sink down smoothly into the spill ring (distributive head) by its own weight.
 (c) Rotate the plunger and repeat the test at various positions.

If the plunger sticks at any position, replace the parts as a set.

- (d) Insert the governor link ball pin into the spill ring and check that it moves smoothly without any play.

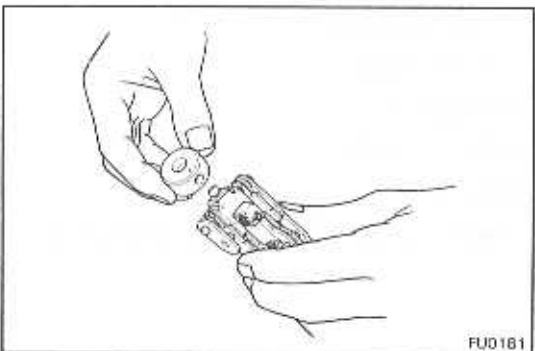

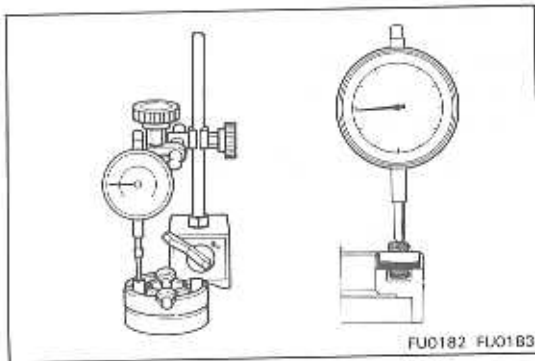

3. INSPECT ROLLER RING AND ROLLERS

Using a dial indicator, measure the roller height.

Roller height variation: 0.02 mm (0.0008 in.)

If not within specification, replace the roller ring and roller as a set.

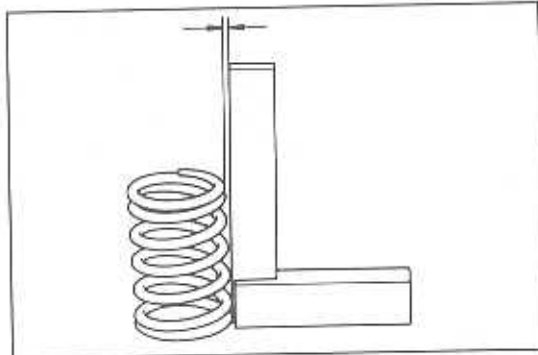

4. INSPECT PLUNGER SPRINGS

Using a steel square, check the squareness of the plunger springs.

Maximum squareness: 2.0 mm (0.079 in.)

If squareness is greater than maximum, replace the plunger spring.

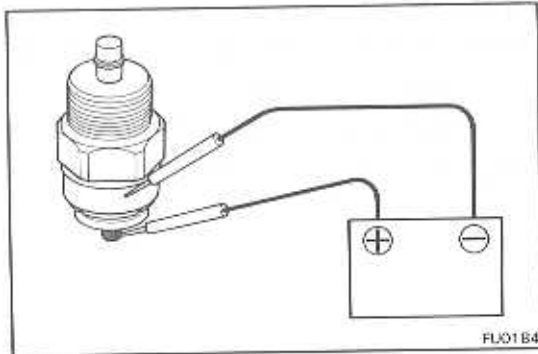

5. INSPECT FUEL CUT SOLENOID

- Install the spring and valve to the solenoid valve body.
- Connect the solenoid valve body and terminal to the battery terminals.
- You should feel the click from the solenoid valve when the battery power is connected and disconnected.

If the solenoid valve is not operating properly, replace it.

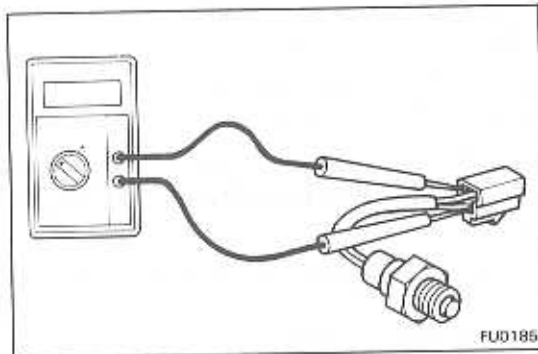

6. INSPECT PICKUP SENSOR

Using an ohmmeter, measure the resistance between terminals.

Resistance: 600 – 800 Ω

If not within specification, replace the sensor.

7. ADJUST PLUNGER SPRING SHIM

- Install the following parts to the distributive head.
 - Two plunger spring guides
 - Two upper spring seats
 - Two plunger springs
 - Lower spring seat
 - Lower plunger plate
 - Upper plunger plate
 - Pump plunger

NOTE: Do not assemble the plunger spring shims at this time.

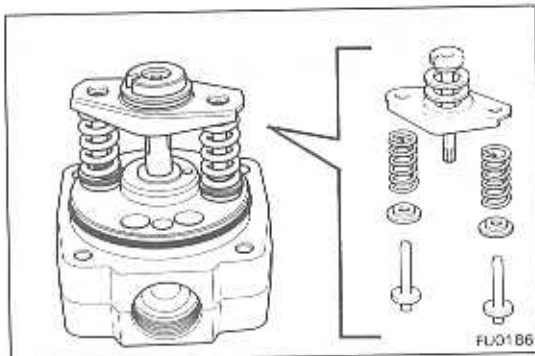

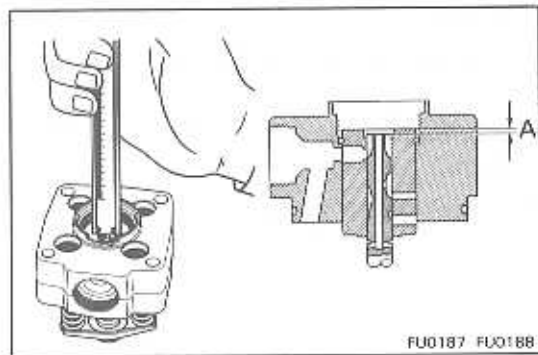

- (b) Using calipers, measure the clearance A indicated in the figure.
- (c) Determine the selection shim size by using the following formula and chart.

$$\begin{aligned} \text{New shim thickness } L, 2L-T &= 5.7 - A \\ 2L &= 5.8 - A \end{aligned}$$

A Plunger position measured

Shim selection chart mm (in.)

Measured clearance	Shim thickness	Measured clearance	Shim thickness
More than 5.3 (0.209)	0.5 (0.020)	4.3-4.5 (0.169-0.177)	1.5 (0.059)
5.0-5.2 (0.196-0.205)	0.8 (0.031)	4.0-4.2 (0.157-0.165)	1.8 (0.071)
4.8-4.9 (0.189-0.193)	1.0 (0.039)	Less than 3.9 (0.154)	2.0 (0.079)
4.6-4.7 (0.181-0.185)	1.2 (0.047)	-	-

NOTE:

- For a measurement between listed sizes, use the next larger size. Ex. If thickness is 1.1 mm (0.043 in.) by calculation, use a 1.2 mm (0.047 in.) shim.
- Select two shims which have the same thickness.

8. IF NECESSARY, REPLACE OIL SEAL

- (a) Using a wrench, pry out the oil seal.

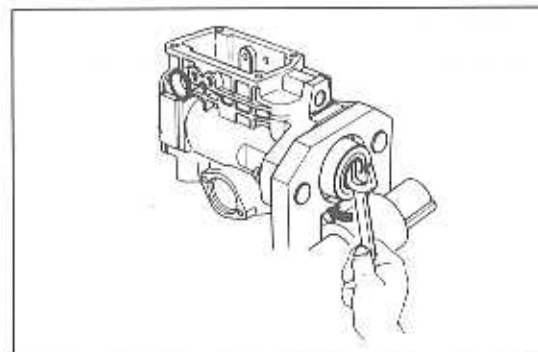

- (b) Apply MP grease to the lip of a new oil seal.
- (c) Apply liquid sealer to the outer circumference of the oil seal.

CAUTION: Do not apply liquid sealer to the lip of the oil seal.

- (d) Using a socket wrench, drive in the oil seal until its surface is flush with the pump housing.

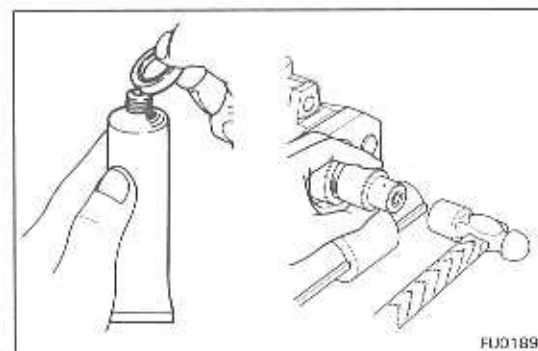

ASSEMBLY OF INJECTION PUMP

(See page FU-15)

1. INSTALL REGULATOR VALVE

Using SST, install and torque the regulator valve with a new O-ring.

Torque: 90 kg-cm (78 in.-lb, 8.8 N·m)

SST 09260-54012

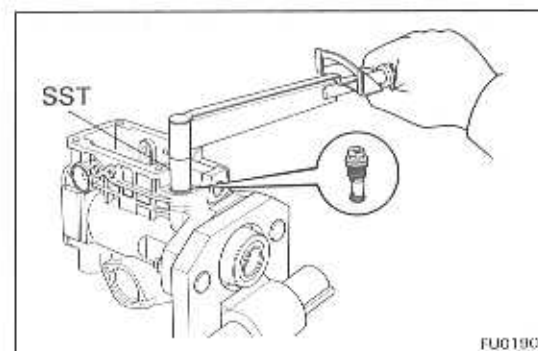

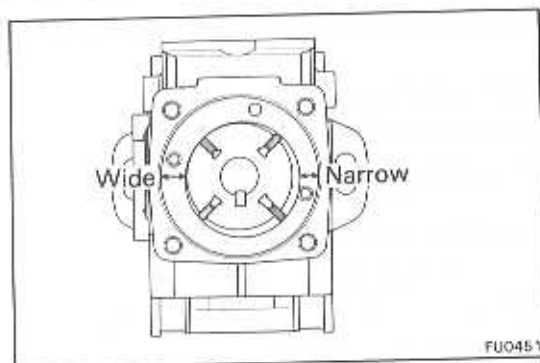

2. INSTALL FEED PUMP

(a) Install the liner, rotor and four blades.

NOTE:

- Check that the liner and blades are facing in the correct direction, as shown.
- Check that the blades move smoothly.

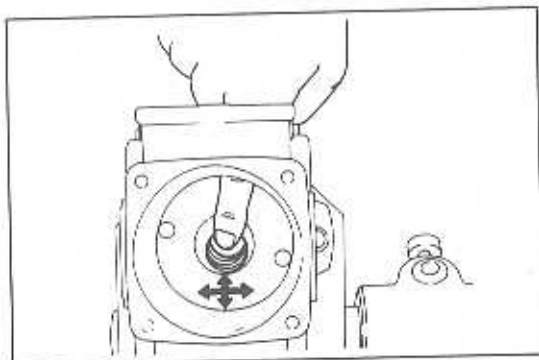

(b) Install the pump cover with the two screws and check that the rotor moves smoothly.

NOTE: Check that the fuel outlet hole of the cover is aligned with the liner.

3. INSTALL DRIVE SHAFT

(a) Install the drive gear on the drive shaft as shown.

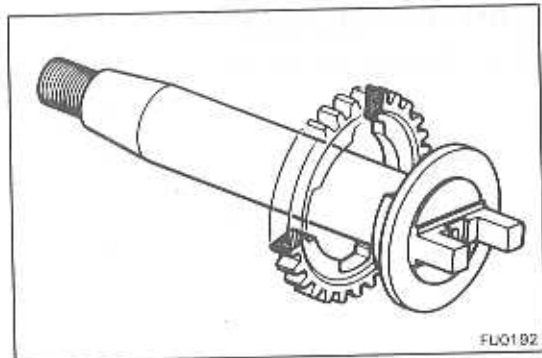

(b) Install new two joint rubbers into the drive gear.

NOTE: Replace the joint rubber when overhauling.

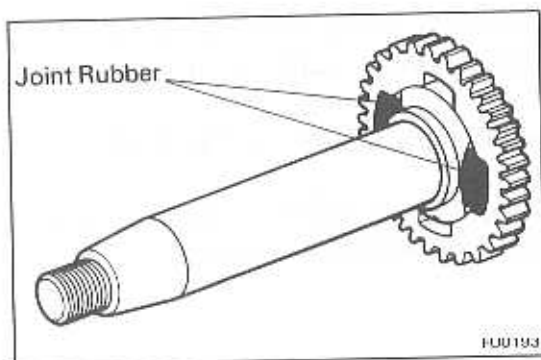

(c) Position the notch of the feed pump rotor upward.

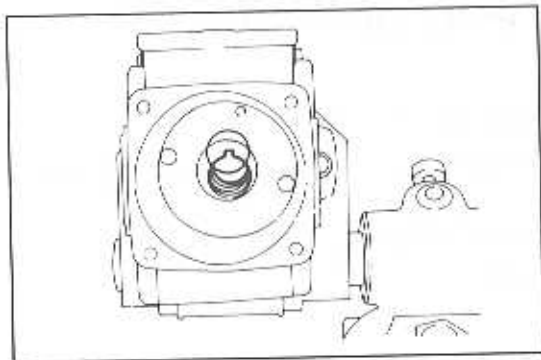

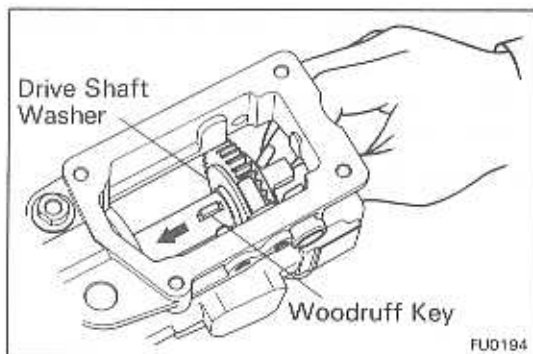

- (d) Install the woodruff key and drive shaft washer on the drive shaft and insert the drive shaft assembly into the pump housing.

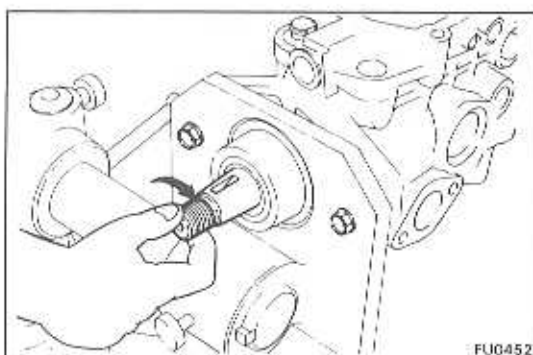

- (e) Check that the drive shaft turns without catching.

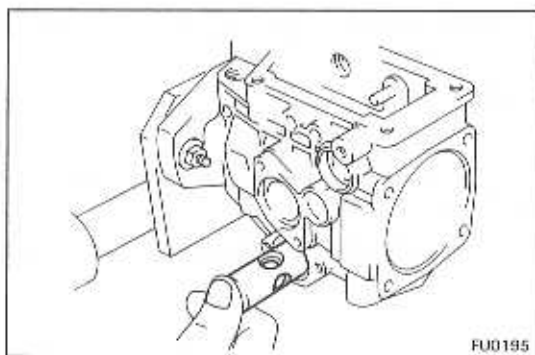

4. INSTALL TIMER PISTON

- (a) Apply No. 50 Denso grease to the timer piston.
 (b) Install the sub-piston in the timer piston.
 (c) Insert the timer piston into the pump housing.

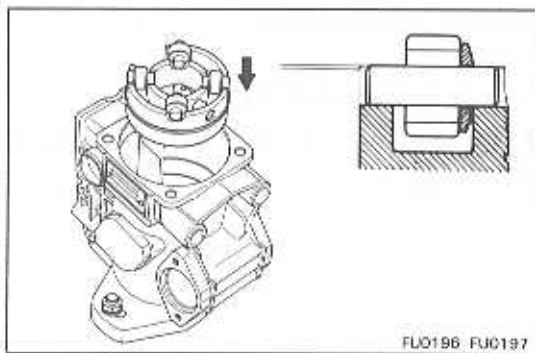

5. INSTALL ROLLER RING

- (a) Install the four rollers and washers on the roller ring.
 NOTE: Check that the roller is facing the flat surface of the washer.
 (b) Install the roller ring with slide pin in the pump housing.

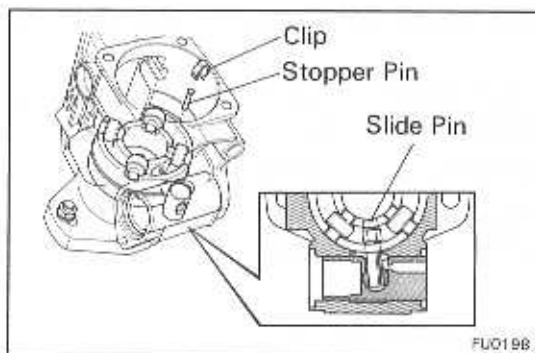

- (c) Carefully push down the slide pin and install the stopper pin and clip.

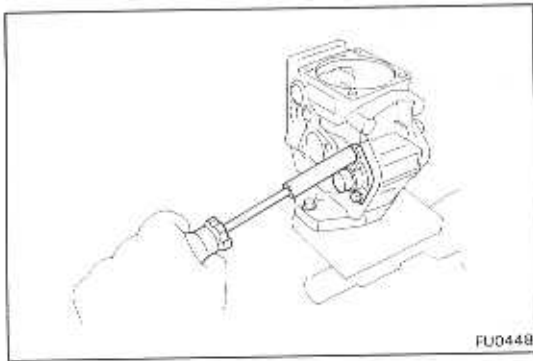

- (d) Install a new O-ring and the RH timer cover with the two bolts.
- (e) Install a new O-ring, the outer spring, washer and LH timer cover with the two bolts.

NOTE: Insert adjusting washer on each side of the spring.

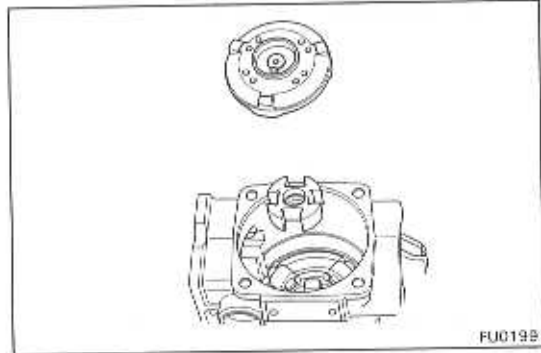

6. ADJUST PLUNGER ADJUSTING SHIM

- (a) Install the coupling and face camplate.

NOTE: Do not assemble the coupling spring.

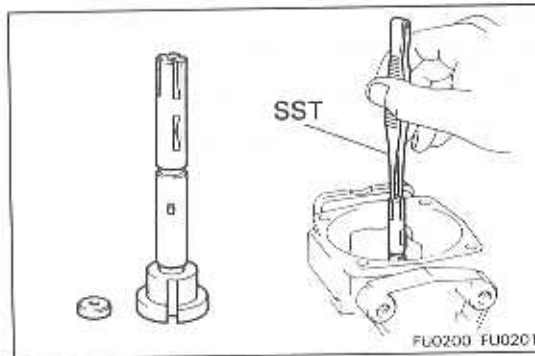

- (b) Using SST, install the used adjusting shim and pump plunger.

SST 09260-54012

NOTE:

- Check that the notch on the pump plunger is aligned with the camplate pin.
- Check the adjusting shim and contacting surface area are clean.

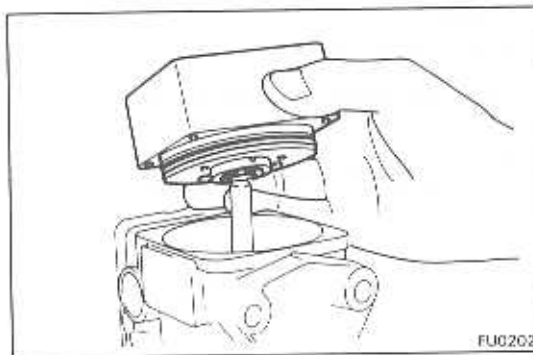

- (c) Install the distributive head with the bolts.
Torque the bolts.

Torque: 120 kg-cm (9 ft-lb, 12 N·m)

CAUTION: Be careful not to damage the pump plunger when assembling.

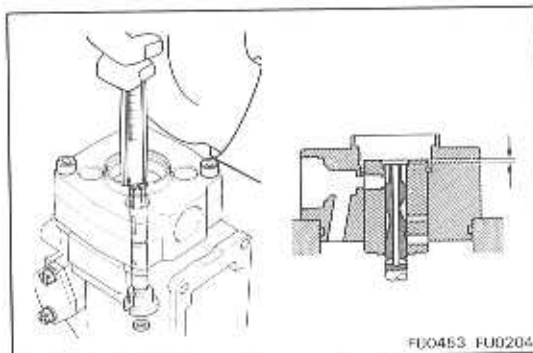

- (d) Using calipers, measure the clearance B indicated in the figure.

- (e) Determine the selection shim size by using the following formula and chart.

$$\text{New shim thickness} = T + (B - 3.3)$$

T... Thickness of shim used

B... Plunger position measured

Shim selection chart

	Measured clearance																				
	(mm)																				
	2.3	2.4	2.5	2.6	2.7	2.8	2.9	3.0	3.1	3.2 - 3.4	3.5	3.6	3.7	3.8	3.9	4.0	4.1	4.2	4.3	4.4	
Installed shim (mm)	1.9											2.1	2.2	2.3	2.4	2.5	2.6	2.7	2.8	2.9	2.9
	2.0								1.9			2.2	2.3	2.4	2.5	2.6	2.7	2.8	2.9	2.9	
	2.1							1.9	1.9			2.3	2.4	2.5	2.6	2.7	2.8	2.9	2.9		
	2.2							1.9	1.9	2.0		2.4	2.5	2.6	2.7	2.8	2.9	2.9			
	2.3						1.9	1.9	2.0	2.1		2.5	2.6	2.7	2.8	2.9	2.9				
	2.4					1.9	1.9	2.0	2.1	2.2		2.6	2.7	2.8	2.9	2.9					
	2.5				1.9	1.9	2.0	2.1	2.2	2.3		2.7	2.8	2.9	2.9						
	2.6			1.9	1.9	2.0	2.1	2.2	2.3	2.4		2.8	2.9	2.9							
	2.7		1.9	1.9	2.0	2.1	2.2	2.3	2.4	2.5		2.9	2.9								
	2.8	1.9	1.9	2.0	2.1	2.2	2.3	2.4	2.5	2.6		2.9									
	2.9	1.9	2.0	2.1	2.2	2.3	2.4	2.5	2.6	2.7											

Plunger adjusting shim thickness	1.9	2.0	2.1	2.2	2.3	2.4	2.5	2.6	2.7	2.8	2.9
mm (in.)	(0.075)	(0.079)	(0.083)	(0.087)	(0.091)	(0.094)	(0.098)	(0.102)	(0.106)	(0.110)	(0.114)

Example: 2.4 mm (0.094 in.) shim installed. Measured clearance is 3.7 mm (0.146 in.) Replace 2.4 mm (0.094 in.) with 2.8 mm (0.110 in.).

(f) Install a shim and recheck clearance B.

B: 3.2 - 3.4 mm (0.126 - 0.134 in.)

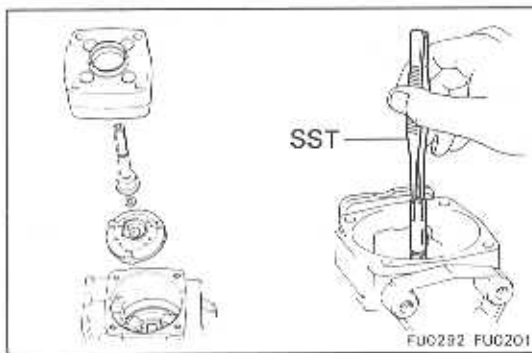
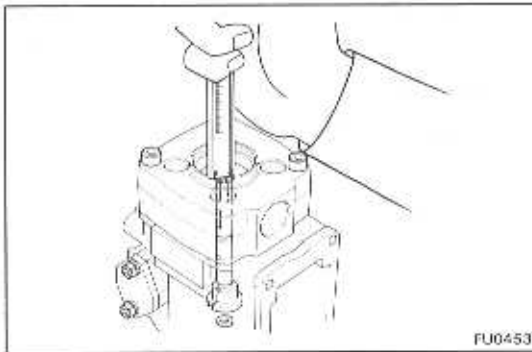

(g) Using SST, remove the following parts:

- (1) Distributive head
- (2) Pump plunger
- (3) Plunger adjusting shim
- (4) Face camplate

SST 09260-54012

7. INSTALL FACE CAMPLATE

(a) Face the key groove of the drive shaft upward.

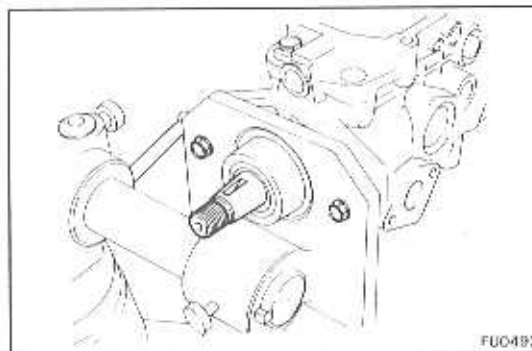

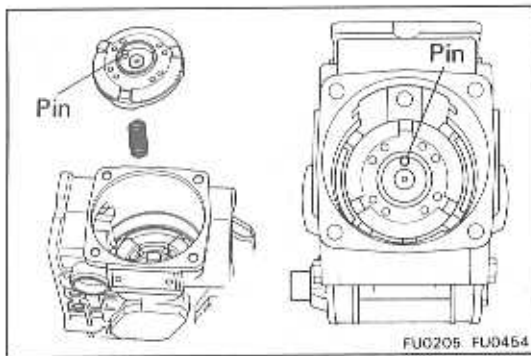

- (b) Install the coupling spring and camplate with the camplate pin facing upward.

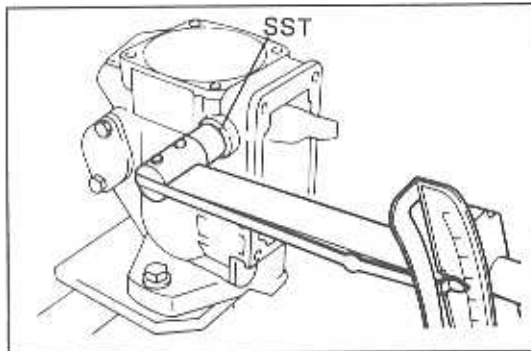

8. INSTALL GOVERNOR LINK

Using SST, install the governor link with the two bolts and new gaskets. Torque the bolts.

Torque: 115 kg-cm (8 ft-lb, 11 N·m)

SST 09260-54012

NOTE: Check that the governor link moves smoothly after assembly.

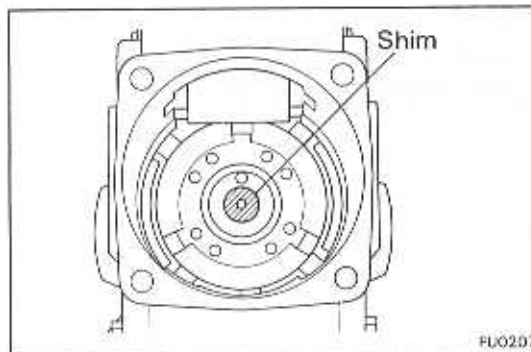

9. INSTALL PUMP PLUNGER

- (a) Place the selected plunger adjusting shim on the center of the camplate.

NOTE: Do not apply grease to the shim.

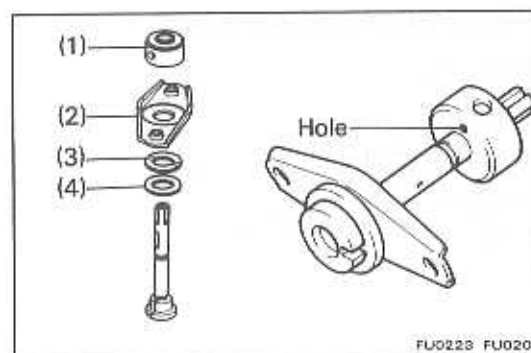

- (b) Install the following parts to the pump plunger:

- (1) Lower plunger plate
- (2) Upper plunger plate
- (3) Lower spring seat
- (4) Spill ring

NOTE: Face the spill ring with the hole side toward the lower seat.

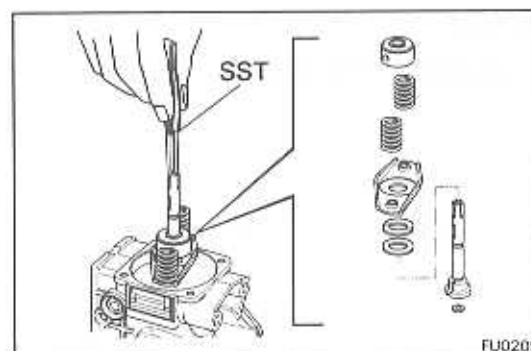

- (c) Using SST, install the pump plunger and plunger spring.

SST 09260-54012

NOTE:

- Check that the camplate pin and plunger notch are aligned.
- Check that the spill ring hole and governor link ball pin are aligned.

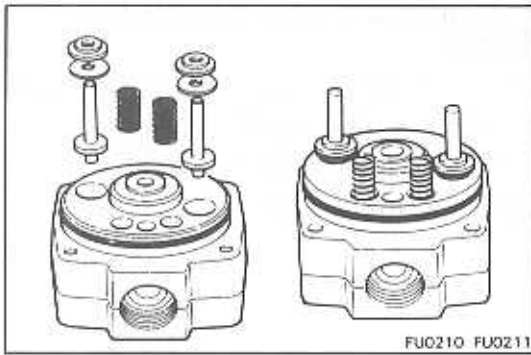

10. INSTALL DISTRIBUTIVE HEAD

(a) Apply No. 50 Denso grease to the following parts and install them to the distributive head:

- (1) Two plunger spring guides
- (2) Two plunger spring shims
- (3) Two upper spring seats
- (4) Two lever support springs
- (5) New O-ring

(b) Install the distributive head.

CAUTION: Be careful not to damage the pump plunger.

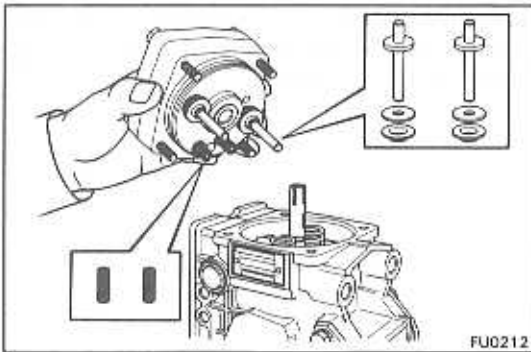

(c) Install and torque the four bolts and wire connector bracket.

Torque: 120 kg-cm (9 ft-lb, 12 N·m)

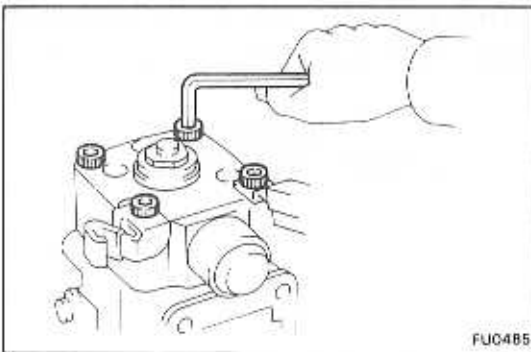

11. INSTALL FOUR DELIVERY VALVE HOLDERS

(a) Install four new gaskets and the valves into the distributive head.

(b) Install the spring seats and springs onto the delivery valve holders.

(c) Using SST, install and torque the delivery valve holders.

Torque: 500 kg-cm (36 ft-lb, 49 N·m)

SST 09260-54012

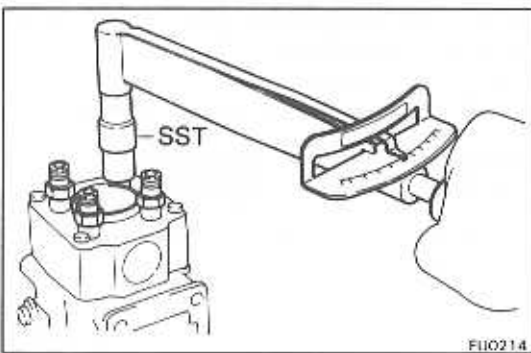

12. INSTALL DISTRIBUTIVE HEAD PLUG

(a) Install a new O-ring on the head plug.

(b) Using SST, install and torque the head plug.

SST 09260-54012

Torque: 700 kg-cm (51 ft-lb, 69 N·m)

CAUTION: If the head plug is removed, always replace the O-ring with a new one.

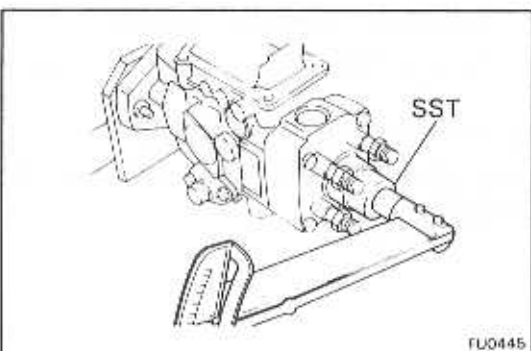

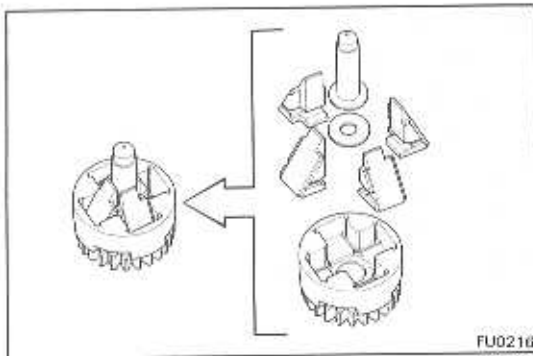

FU0216

13. INSTALL GOVERNOR SHAFT AND FLYWEIGHT HOLDER ASSEMBLY

- (a) Install the four flyweights, No. 2 flyweight washer and governor sleeve on the flyweight holder.

NOTE: Replace the four flyweights as a set.

- (b) Install a new O-ring to the governor shaft.

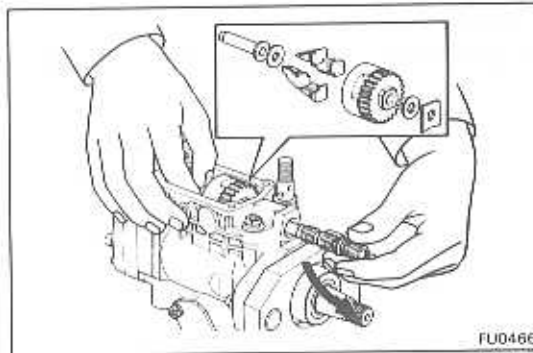

FU0466

- (c) Install the governor shaft, gear adjusting washer, No. 1 flyweight washer and flyweight holder assembly together, and turn the governor shaft counterclockwise.

14. CHECK FLYWEIGHT HOLDER THRUST CLEARANCE

Using a feeler gauge, measure the flyweight holder thrust clearance.

Thrust clearance: **0.15 – 0.35 mm**
(0.0059 – 0.0138 in.)

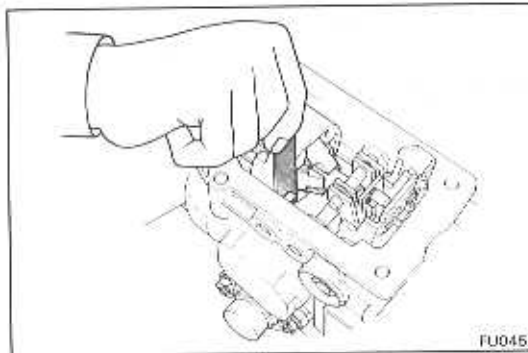

FU0456

If the thrust clearance is not within specification, adjust with a governor gear adjusting washer.

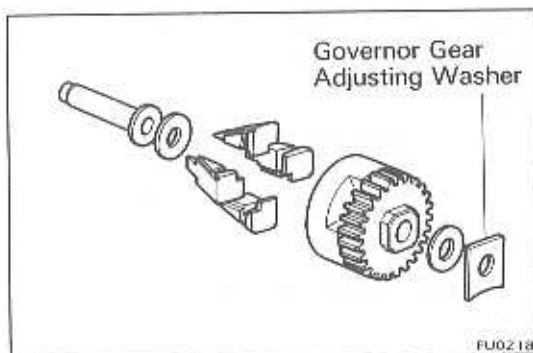

FU0218

Governor gear adjusting washer thickness mm (in.)	
1.05 (0.0413)	1.65 (0.0650)
1.25 (0.0492)	1.85 (0.0728)
1.45 (0.0571)	

15. ADJUST PROTRUSION OF GOVERNOR SHAFT

- (a) Using calipers, measure the protrusion of the governor shaft.

Protrusion: **2.0 – 2.5 mm (0.079 – 0.098 in.)**

If the protrusion is not within specification, adjust by turning the governor shaft.

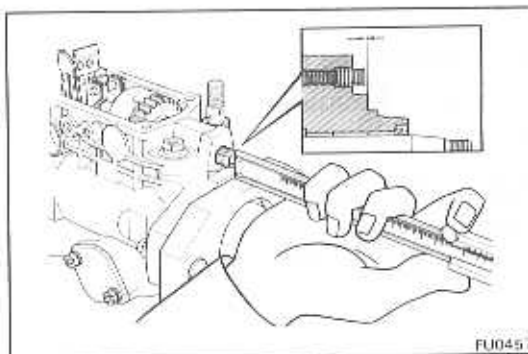

FU0457

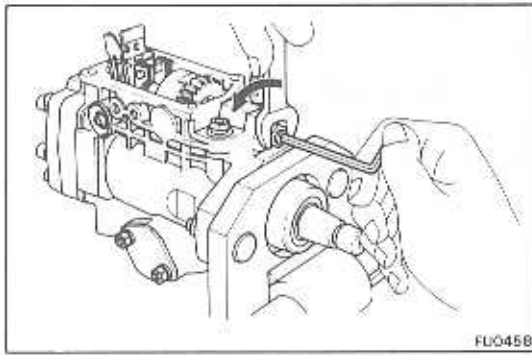

FU0458

- (b) Install and torque the lock nut while holding the governor shaft with an allen wrench.

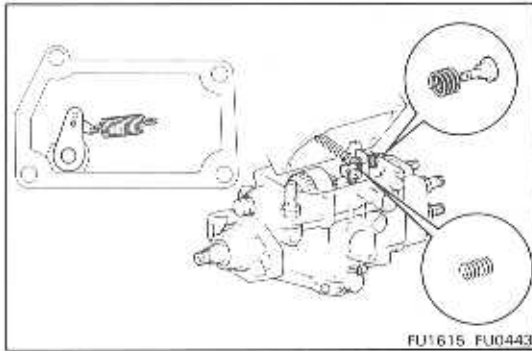

FU1615 FU0443

16. INSTALL GOVERNOR COVER

- (a) Install a new gasket into the groove of the governor cover.
 (b) [M/T (ex. LX)]
 Install the damper spring and governor spring seat, and connect them with the control spring.

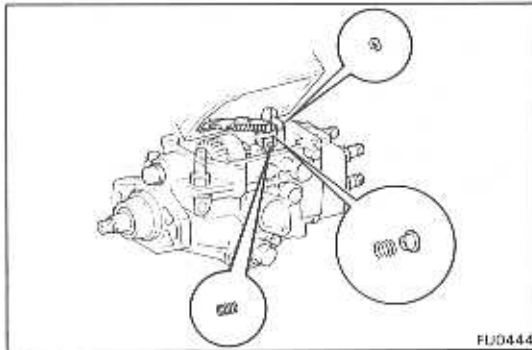

FU0444

[M/T (LX) & A/T]

Install the damper spring and governor spring seat and connect them with the E-ring.

- (c) Install the governor cover with the four bolts.

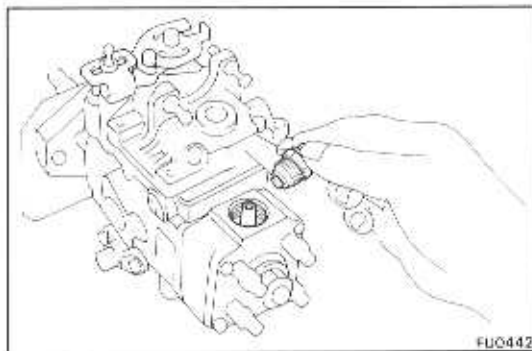

FU0442

17. INSTALL FUEL CUT SOLENOID

- (a) Install a new O-ring on the fuel cut solenoid.
 (b) Install the valve and spring.
 (c) Install the fuel cut solenoid.
 (d) Connect the lead wire to the fuel cut solenoid.
 (e) Install the lead wire connector to bracket.

18. INSTALL NEW GASKET AND PICKUP SENSOR

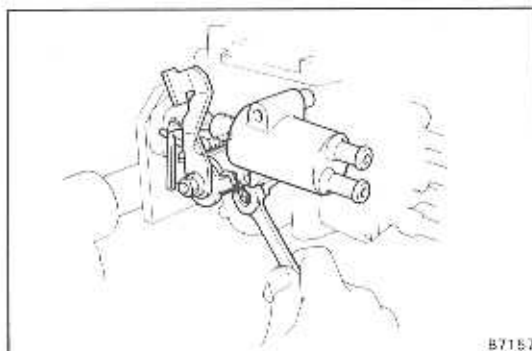

B7187

**19. [LX]
 INSTALL THERMO WAX**

Install a new O-ring and thermo wax with two bolts.

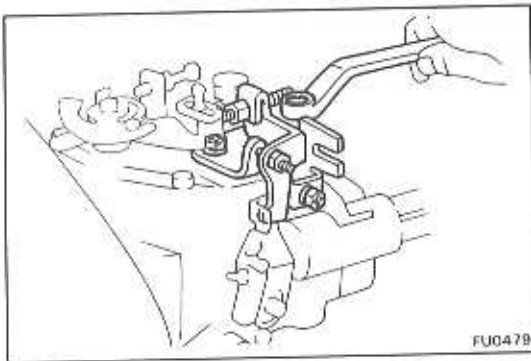

FU0479

20. [LX]**INSTALL IDLE-UP**

Install the idle-up with three bolts.

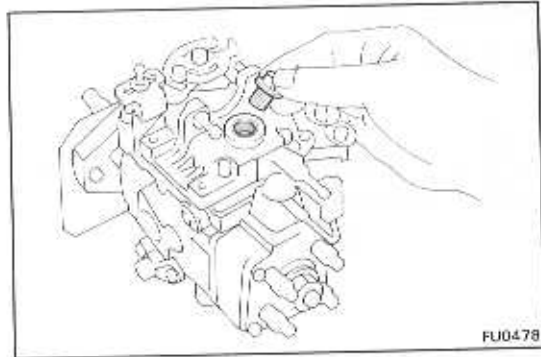
21. REMOVE INJECTION PUMP FROM STAND

FU0478

22. PERFORM AIR TIGHT TEST

(a) Install a bolt to the overflow port.

(b) Connect an air hose to the fuel inlet pipe and place the injection pump into diesel fuel.

(c) Apply 1.5 kg/cm² (21 psi, 147 kPa) of pressure and confirm that there are no leaks.

(d) Next check that there are no leaks with 5.0 kg/cm² (71 psi, 490 kPa) of pressure applied.

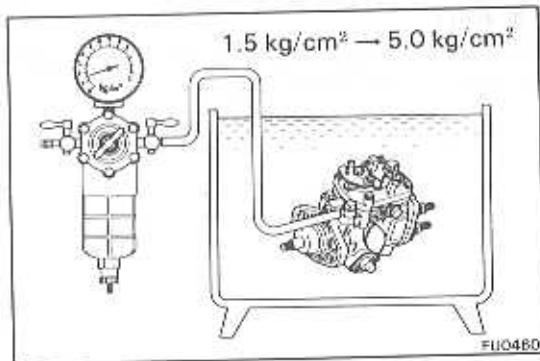

FU0480

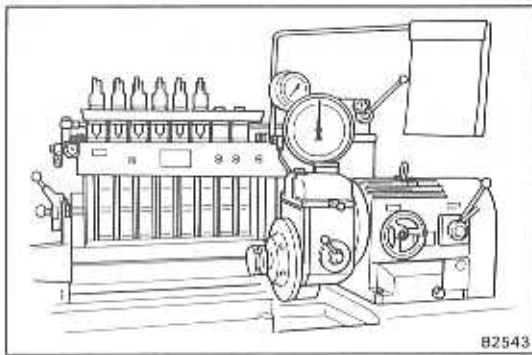

ADJUSTMENT OF INJECTION PUMP

1. PRE-TEST CHECK AND PREPARATION

- (a) The specifications for test nozzle and nozzle holders are as follows.

Test nozzle: DN12SD12 (NIPPONDENSO)

Test nozzle holder valve opening pressure:

145 – 155 kg/cm²

(2,062 – 2,205 psi, 14,220 – 15,200 kPa)

- (b) Check the accuracy of the tachometer.

Allowable error: ± 40 rpm

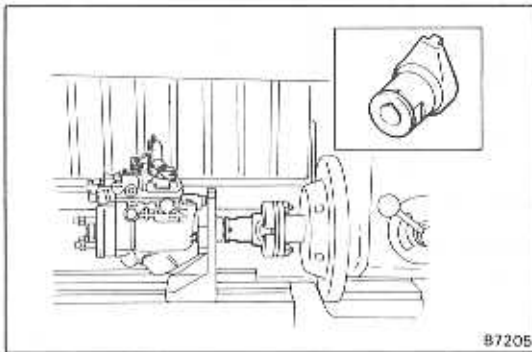
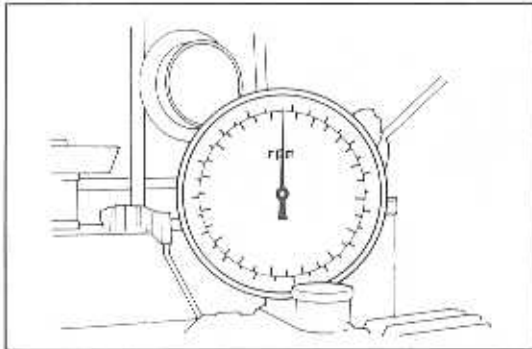

- (c) Install the angle gauge stand.

- (d) Mount the injection pump body on the pump tester.

NOTE: Place a mark on the key groove portion of the coupling.

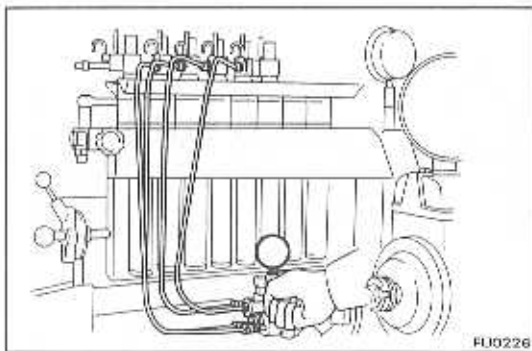

- (e) Connect the injection pump to the pump tester with high pressure pipes of the following dimensions.

Outer diameter: 6.0 mm (0.236 in.)

Inner diameter: 2.0 mm (0.079 in.)

Length: 840 mm (33.07 in.)

Minimum bending radius: More than 25 mm (0.98 in.)

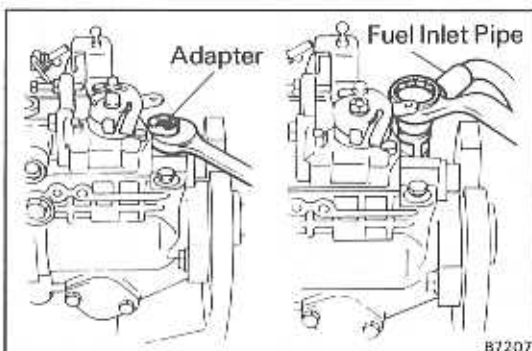

- (f) Remove the fuel inlet union.

- (g) Connect the fuel inlet pipe with an adapter.

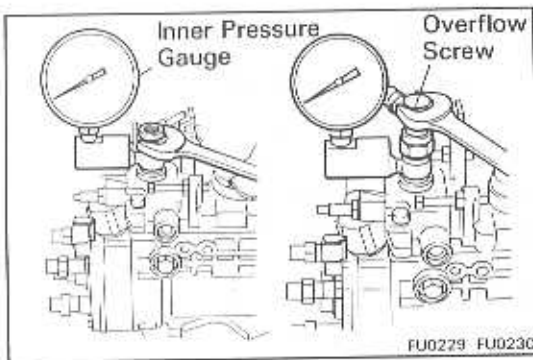

- (g) Install the inner pressure gauge with a hollow screw. On top, install an overflow hose with the overflow screw.

NOTE: Always use the overflow screw installed on the pump to be adjusted.

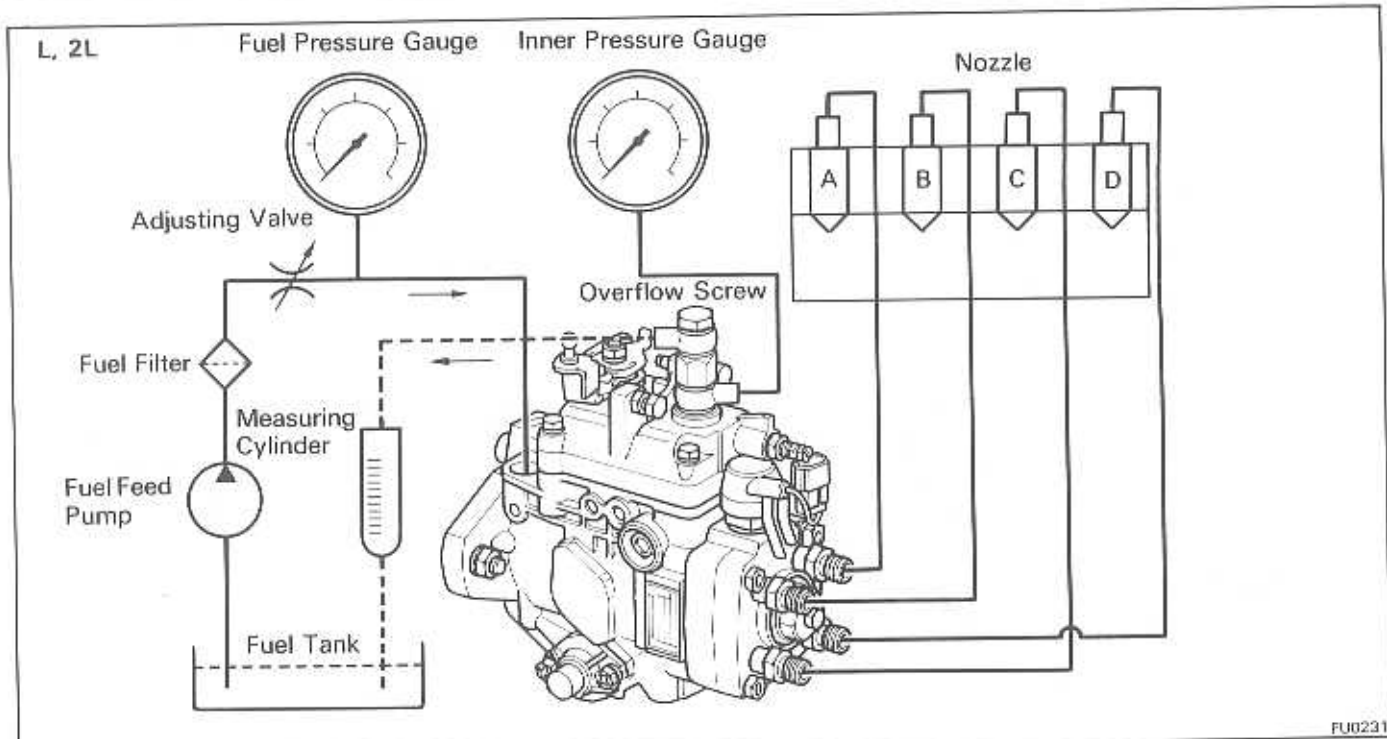

FU0231

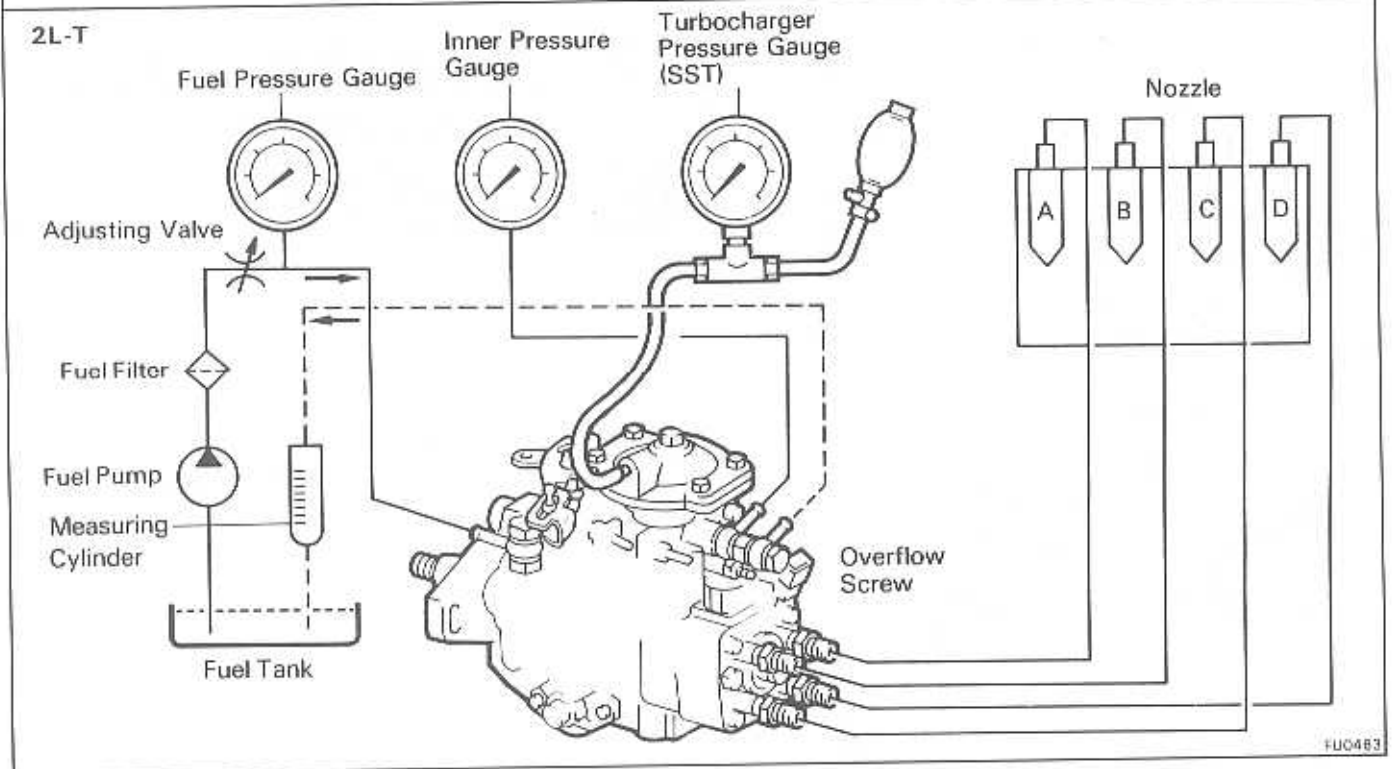

FU0483

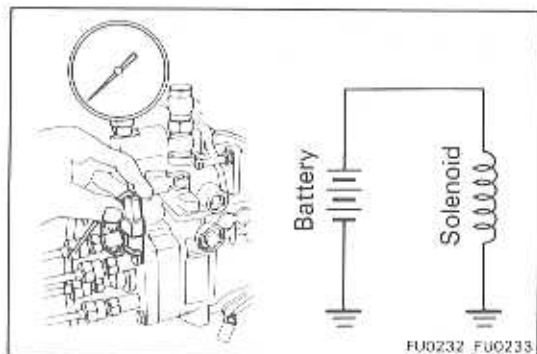

FU0232 FU0233

- (h) Apply about 12 volts of DC power to the fuel cut solenoid.

CAUTION:

1. When applying voltage to the solenoid, position the battery as far away from the solenoid as possible so that a spark does not occur.
2. When connecting the battery cable, connect the solenoid side first.

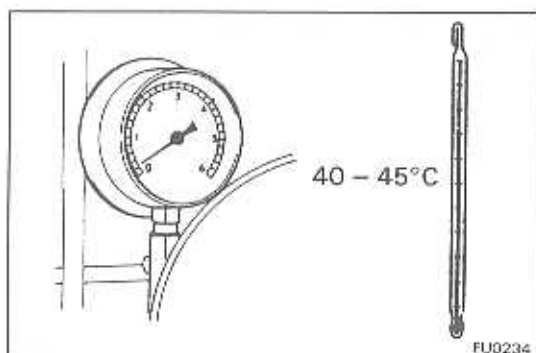

FU0234

- (i) The pressure for feeding fuel to the injection pump should be 0.2 kg/cm² (2.8 psi, 20 kPa). The fuel temperature for pump testing should be 40 - 45°C (104 - 113°F).

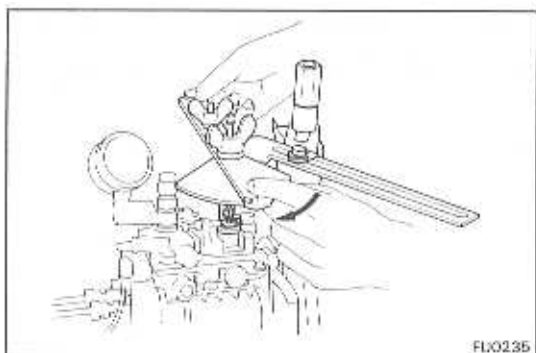

FU0235

- (j) Install an angle gauge to the stand and set it to the adjusting lever.
- (k) Secure the adjusting lever fully on the maximum speed side.

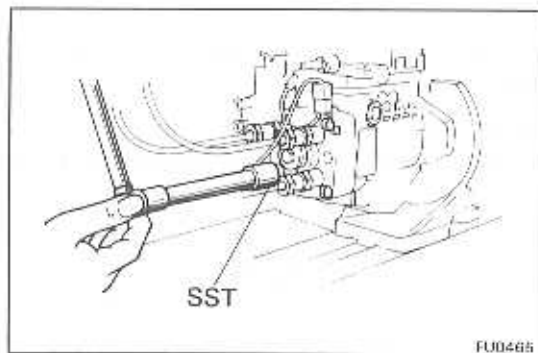

FU0465

- (l) Check the installation direction of the camplate.
- (1) Disconnect the injection pipe from the position marked "C" on the distributive head.
 - (2) Using SST, remove the delivery valve holder.

SST 09260-54012

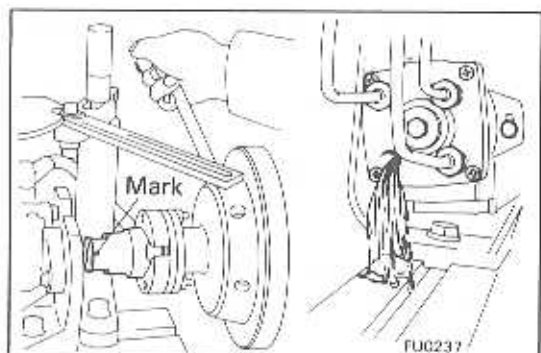

FU0237

- (3) Check that fuel is flowing out when the mark is in the position shown in the figure. If not, it is improperly assembled.
- (4) Disassemble and change the camplate position 180° in the opposite direction.

NOTE: Disconnect the fuel cut solenoid wire harness.

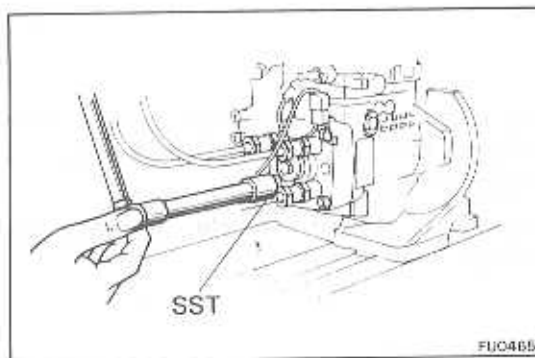

- (5) Using SST, install the delivery valve holder.
SST 09260-54012
- (6) Connect the injection pipe.

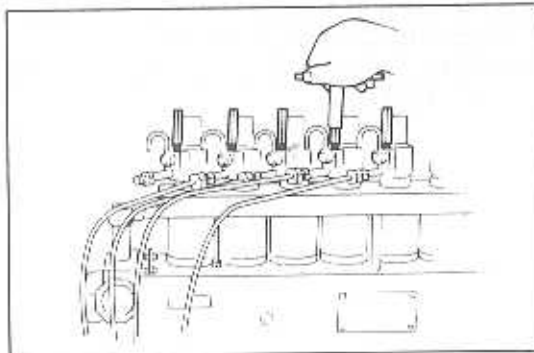

- (m) Bleed the air from the injection pipes.

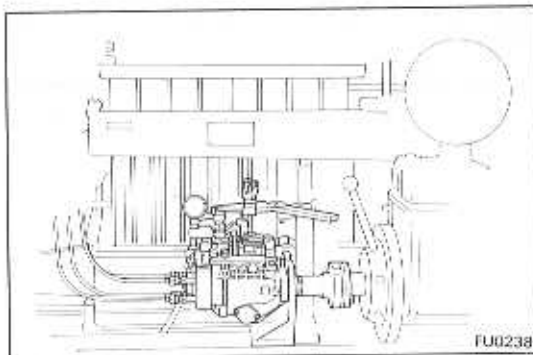

- (n) Race the injection pump for 5 minutes at 2,000 rpm.
CAUTION: Check that there is no fuel leakage or abnormal noise.

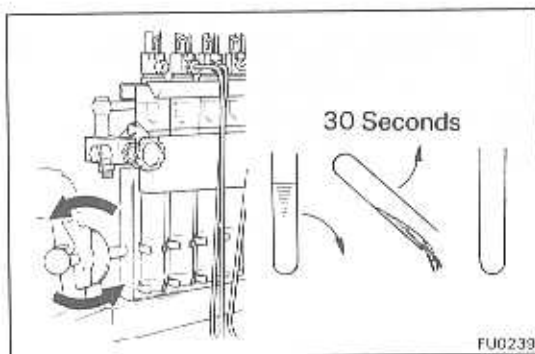

NOTE:

- Measure the volume of each injection cylinder with a measuring cylinder.
- Before measuring the injection volume first hold the cylinder tilted for at least 30 seconds to discard all the fuel.

L, 2L

Full Load Set Screw

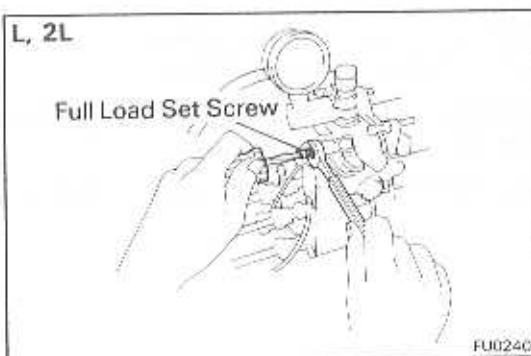

2. PRE-SETTING OF FULL LOAD INJECTION VOLUME

- (a) (2L-T)
Apply 0.48 kg/cm² (6.8 psi, 47 kPa) of pressure to the boost compensator.
- (b) Adjust the injection volume with the FULL LOAD SET SCREW.

Item	Pump rpm	No. of measuring strokes	Injection volume cc (cu. in.)
L	1,200	200	7.54 – 7.86 (0.46 – 0.48)

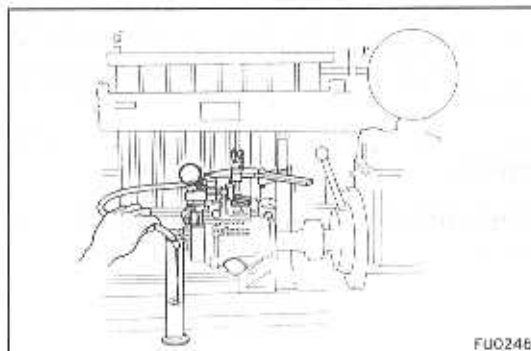
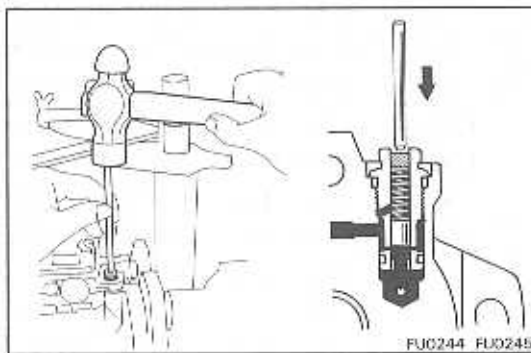
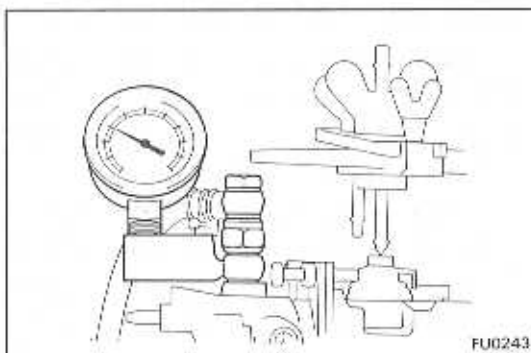
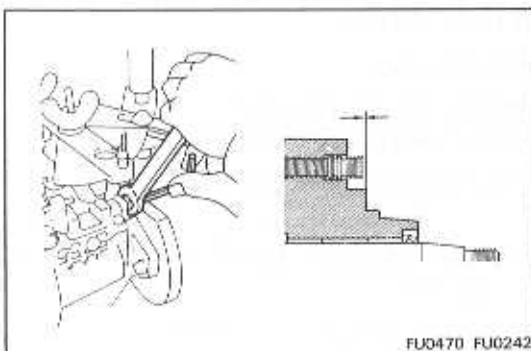
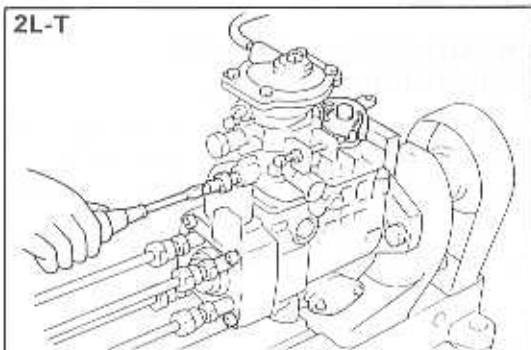

Cont'd

Item	Pump rpm	No. of measuring strokes	Injection volume cc (cu. in.)
2L	1,200	200	9.34 - 9.66 (0.57 - 0.59)
			9.24 - 9.56 (0.56 - 0.58)
2L-T	1,200	200	10.4 - 13.6 (0.63 - 0.83)

NOTE: The injection volume will increase about 3 cc (0.2 cu in.) with each 1/2 turn of the screw.

3. PRE-SETTING OF LOAD SENSING TIMER

Adjust the protrusion of the governor shaft.

Protrusion: 2.0 - 2.5 mm (0.079 - 0.098 in.)

4. ADJUST PUMP INNER PRESSURE

Measure the pump inner pressure at each of the listed rpms.

Item	Pump rpm	Inner pressure kg/cm ² (psi, kPa)
2L	LS Hong Kong & Singapore	400 2.2 - 2.8 (31 - 40, 216 - 275)
		1,850 5.8 - 6.4 (82 - 91, 569 - 628)
	LN56 & LY Australia	400 2.2 - 2.8 (31 - 40, 216 - 275)
		2,000 6.2 - 6.8 (88 - 97, 608 - 667)
Others	400 2.2 - 2.8 (31 - 40, 216 - 275)	
	2,200 6.7 - 7.3 (95 - 104, 657 - 716)	

If the pressure is low, adjust by lightly tapping the regulator valve piston while watching the pressure gauge.

NOTE: If the pressure is too high or if the regulator valve was tapped in too far, it must be replaced.

5. CHECK OVERFLOW VOLUME

Measure the overflow volume at the below listed rpm.

Item	Pump rpm	Over flow volume cc/min. (cu. in./min.)
2L	LS Hong Kong & Singapore	1,850 330 - 750 (20.1 - 45.8)
		LN56 & LY Australia 2,000 350 - 770 (21.4 - 47.0)
Others	2,200	370 - 800 (22.6 - 48.8)

NOTE: Always use the overflow screw installed on the pump to be adjusted.

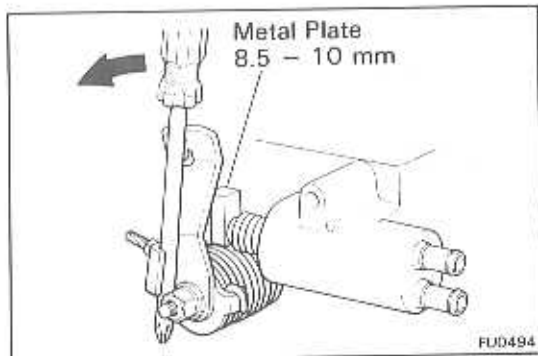

6. [LX]
RELEASE COLD STARTING SYSTEM FOR FOLLOWING INSPECTIONS

Using a screwdriver, turn the cold start lever counterclockwise and put a metal plate of 8.5 – 10 mm (0.335 – 0.394 in.) in thickness between the lever and thermo wax.

NOTE: Keep the cold starting system released until all measurements and adjustments are finished.

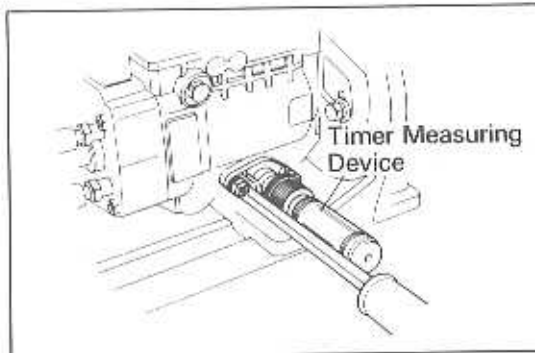

7. **CHECK AND ADJUST TIMER**

- (a) Remove the timer cover.
- (b) Install the timer measuring device.
Part No. 95095-10220 (NIPPONDENSO)
- (c) Set the timer measuring device at zero.
- (d) (2L-T)
Apply 0.48 kg/cm² (6.8 psi, 47 kPa) of pressure to the boost compensator.
- (e) Measure the piston stroke at the below listed rpms.

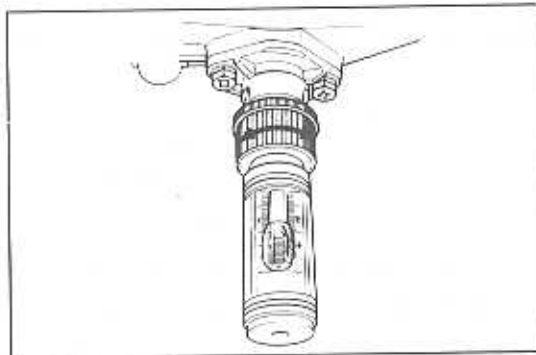

Item	Pump rpm	Piston stroke mm (in.)	
L	800	0.8 – 1.6 (0.031 – 0.063)	
	1,200	2.4 – 3.2 (0.094 – 0.126)	
	2,000	5.6 – 6.4 (0.220 – 0.252)	
	2,300	6.36 – 7.16 (0.2504 – 0.2819)	
2L	LX	800	2.0 – 2.8 (0.079 – 0.110)
		1,200	3.6 – 4.4 (0.142 – 0.173)
		2,000	6.8 – 7.6 (0.268 – 0.299)
		2,300	7.6 – 8.4 (0.299 – 0.331)
	LS Hong kong & Singapore	800	0.8 – 1.6 (0.031 – 0.063)
		1,200	2.4 – 3.2 (0.094 – 0.126)
		1,750	4.55 – 5.35 (0.1791 – 0.2106)
	LN56 & LY Australia	800	0.8 – 1.6 (0.031 – 0.063)
		1,200	2.4 – 3.2 (0.094 – 0.126)
		1,900	5.2 – 6.0 (0.205 – 0.236)
	Others	800	0.8 – 1.6 (0.031 – 0.063)
		1,200	2.4 – 3.2 (0.094 – 0.126)
2,000		5.6 – 6.4 (0.220 – 0.252)	
2,300		6.36 – 7.16 (0.2504 – 0.2819)	
2L-T	800	1.9 – 2.7 (0.075 – 0.106)	
	1,200	3.3 – 4.1 (0.130 – 0.161)	
	2,000	6.1 – 6.9 (0.240 – 0.272)	
	2,300	6.76 – 7.58 (0.2661 – 0.2984)	

If any stroke is not within standard, adjust with the **TIMER ADJUSTING SCREW**.

CAUTION: Check that there is a washer on LH cover side of the spring.

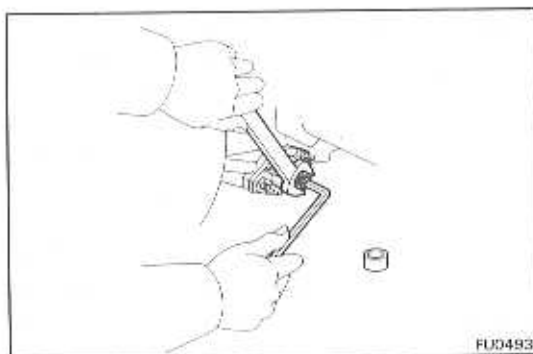

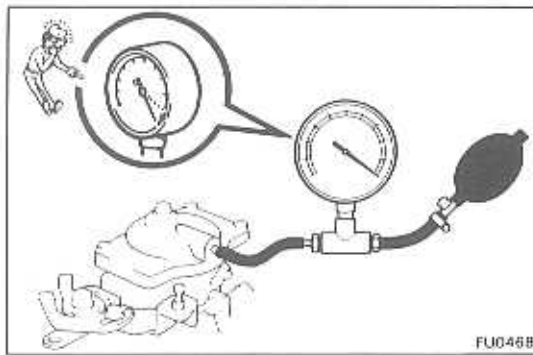

FU046B

8. [2L-T]
INSPECT AIR TIGHTNESS OF BOOST COMPENSATOR
- Apply 1.36 kg/cm² (19.3 psi, 133 kPa) of pressure to the boost compensator.
 - Measure the time it takes for the pressure to drop to 1.33 kg/cm² (18.9 psi, 130 kPa).

Pressure drop: More than 10 seconds

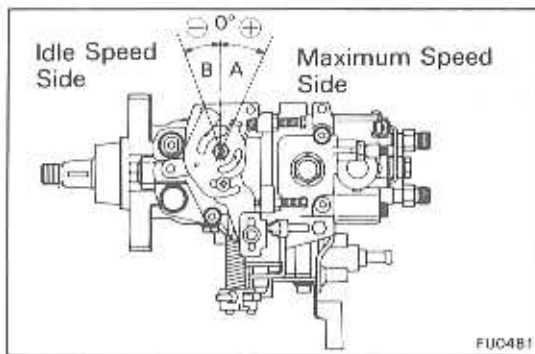

FU0481

9. **CHECK AND ADJUST FULL LOAD INJECTION VOLUME**

- The adjusting lever angle for the adjustment below should be as shown in the figure.

Item	Adjusting lever angle	
	A (Maximum speed side)	B (Idle speed side)
L	Plus 9.0 – 19.0°	Minus 14.0 – 24.0°
2L	LX & A/T	Plus 23.5 – 33.5°
	LS Hong Kong & Singapore	Plus 20.5 – 30.5°
	Others	Plus 23.5 – 33.5°
2L-T	Plus 23.5 – 33.5°	Minus 13.5 – 21.5°

- (2L-T)
 Apply 0.48 kg/cm² (6.8 psi, 47 kPa) of pressure to the boost compensator.
- Measure the full load injection volume.

Item	Adjusting lever angle	Pump rpm	No. of measuring strokes	Injection volume cc (cu. in.)
L	Plus 9.0 – 19.0°	1,200	200	7.54 – 7.86 (0.46 – 0.48)
2L	ex. LS Hong Kong & Singapore	1,200	200	9.34 – 9.66 (0.57 – 0.59)
	LS Hong Kong & Singapore	1,200	200	9.24 – 9.56 (0.56 – 0.58)
2L-T	Plus 23.5 – 33.5°	1,200	200	10.04 – 10.36 (0.61 – 0.63)

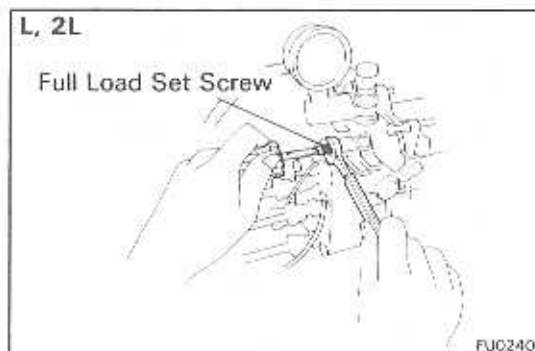

FU0240

If any injection volume is not at standard value, adjust with the FULL LOAD SET SCREW.

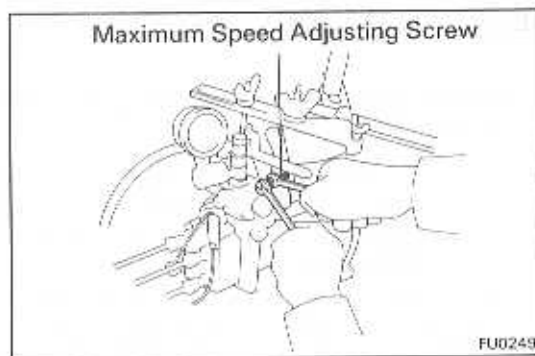
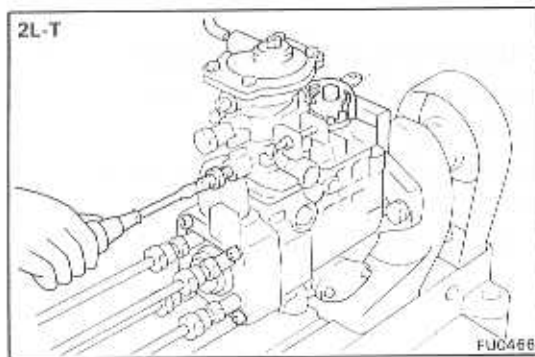

10. ADJUST MAXIMUM SPEED

Adjust to the standard value with the MAXIMUM SPEED ADJUSTING SCREW.

Item		Adjusting lever angle	Pump rpm	No. of measuring strokes	Injection volume cc (cu. in.)	Remarks
L		Plus 9.0 – 19.0°	2,450	200	3.9 – 4.5 (0.24 – 0.27)	Adjust
			2,250	200	5.7 – 6.9 (0.35 – 0.42)	Check
			2,700	200	Less than 1.3 (0.08)	Check
2L	ex. LS Hong Kong & Singapore	Plus 23.5 – 33.5°	2,450	200	3.8 – 5.4 (0.23 – 0.33)	Adjust
			2,250	200	6.8 – 8.0 (0.41 – 0.49)	Check
			2,700	200	Less than 1.3 (0.08)	Check
	LS Hong Kong & Singapore	Plus 20.5 – 30.5°	2,250	200	3.8 – 5.4 (0.23 – 0.33)	Adjust
			2,000	200	7.4 – 8.6 (0.45 – 0.52)	Check
			2,500	200	Less than 1.3 (0.08)	Check
2L-T *		Plus 23.5 – 33.5°	2,450	200	3.2 – 5.2 (0.20 – 0.32)	Adjust
			2,250	200	6.7 – 8.5 (0.41 – 0.52)	Check
			2,700	200	Less than 1.3 (0.08)	Check

* Apply 0.48 kg/cm² (6.8 psi, 47 kPa) pressure

11. CHECK INJECTION VOLUME

Measure the injection volume for each pump rpm.

Item	Adjusting lever angle	Pump rpm	No. of measuring strokes	Injection volume cc (cu. in.)	Variation limit cc (cu. in.)	Remarks
L	Plus 9.0 – 19.0°	1,200	200	7.54 – 7.86 (0.46 – 0.48)	0.4 (0.02)	Basic full-load injection volume
		100	200	8.2 – 12.0 (0.50 – 0.73)	0.8 (0.05)	Volume during starting
		350	200	7.0 – 9.6 (0.43 – 0.59)	0.5 (0.03)	–
		500	200	6.3 – 7.3 (0.38 – 0.45)	0.5 (0.03)	–
		2,100	200	6.5 – 7.4 (0.40 – 0.45)	0.5 (0.03)	–

Cont'd

Item	Adjusting lever angle	Pump rpm	No. of measuring strokes	Injection volume cc (cu. in.)	Variation limit cc (cu. in.)	Remarks	
2L	LN56 & LY Australia	Plus 23.5 – 33.5°	1,200	200	9.34 – 9.66 (0.57 – 0.59)	0.4 (0.02)	Basic full-load injection volume
			100	200	8.6 – 12.4 (0.52 – 0.76)	0.8 (0.05)	Volume during starting
			500	200	7.2 – 8.2 (0.44 – 0.50)	0.5 (0.03)	–
			2,000	200	7.8 – 8.7 (0.48 – 0.53)	0.5 (0.03)	–
	LS Hong Kong & Singapore	Plus 20.5 – 30.5°	1,200	200	9.24 – 9.56 (0.56 – 0.58)	0.4 (0.02)	Basic full-load injection volume
			100	200	6.6 – 10.4 (0.40 – 0.63)	0.8 (0.05)	Volume during starting
			500	200	7.6 – 8.6 (0.46 – 0.52)	0.5 (0.03)	–
			1,850	200	8.1 – 9.0 (0.49 – 0.55)	0.5 (0.03)	–
	M/T, ex. LS Hong Kong, Singapore & Australia (LN56 & LY)	Plus 23.5 – 33.5°	1,200	200	9.34 – 9.66 (0.57 – 0.59)	0.4 (0.02)	Basic full-load injection volume
			100	200	8.6 – 12.4 (0.52 – 0.76)	0.8 (0.05)	Volume during starting
			500	200	7.2 – 8.2 (0.44 – 0.50)	0.5 (0.03)	–
			2,100	200	7.6 – 8.5 (0.46 – 0.52)	0.5 (0.03)	–
350			200	7.7 – 10.3 (0.47 – 0.63)	0.5 (0.03)	–	
A/T & LX, ex. LS Hong Kong & Singapore	Plus 23.5 – 33.5°	1,200	200	9.34 – 9.66 (0.57 – 0.59)	0.4 (0.02)	Basic full-load injection volume	
		100	200	8.6 – 12.4 (0.52 – 0.76)	0.8 (0.05)	Volume during starting	
		500	200	7.2 – 8.2 (0.44 – 0.50)	0.5 (0.03)	–	
		2,100	200	7.6 – 8.5 (0.46 – 0.52)	0.5 (0.03)	–	
2L-T	Plus 23.5 – 33.5°	*1 1,200	200	10.04 – 10.36 (0.61 – 0.63)	0.4 (0.02)	Basic full-load injection volume	
		100	200	10.2 – 13.6 (0.62 – 0.83)	0.8 (0.05)	Volume during starting	
		*2 500	200	7.3 – 8.1 (0.45 – 0.49)	0.5 (0.03)	–	
		*1 2,100	200	10.0 – 11.2 (0.61 – 0.68)	0.5 (0.03)	–	

*1: Apply 0.48 kg/cm² (6.8 psi, 47 kPa) pressure*2: Apply 0.04 kg/cm² (0.57 psi, 3.9 kPa) pressure

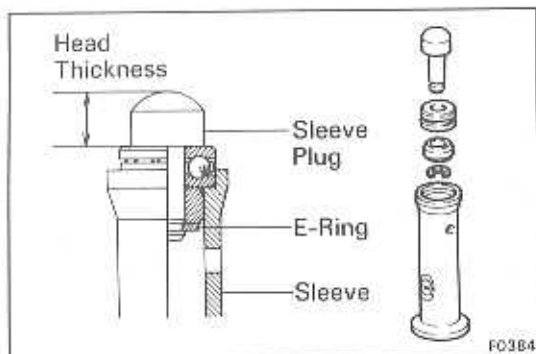

If the injection volume at 100 rpm is not within standard, replace the governor sleeve plug.

Governor sleeve plug head thickness		mm (in.)
3.3	(0.130)	3.7 (0.146)
3.4	(0.134)	3.8 (0.150)
3.5	(0.138)	3.9 (0.154)
3.6	(0.142)	4.0 (0.157)

NOTE: Lengthening the plug 0.1 mm (0.004 in.) will decrease injection volume by 0.6 cc (0.04 cu. in.).

If the variation limit exceeds specification, replace the delivery valve.

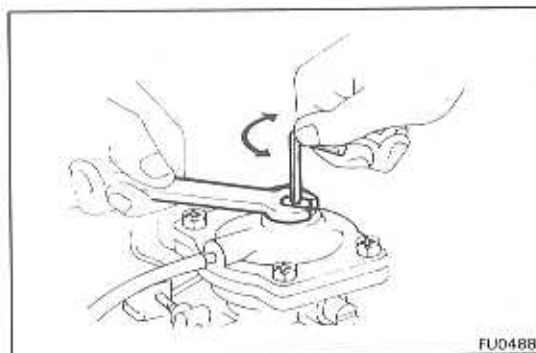

12. [2L-T] MEASURE AND ADJUST FULL LOAD MINIMUM INJECTION VOLUME

(a) Measure the injection volume.

Pump rpm	No. of measuring strokes	Injection volume cc (cu. in.)
1,200	200	7.9 - 8.7 (0.48 - 0.53)

(b) Using an allen wrench, adjust the timer slide stopper.

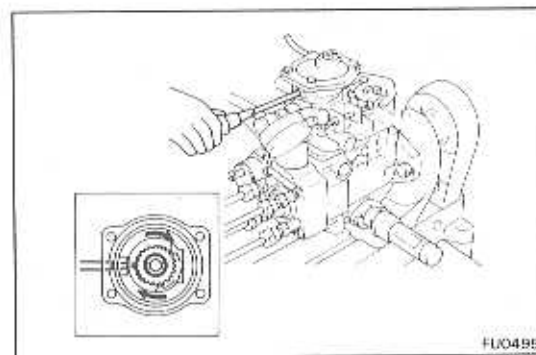

13. [2L-T] MEASURE AND ADJUST BOOST COMPENSATOR CHARACTERISTIC

(a) Apply 0.14 kg/cm² (2.0 psi, 14 kPa) of pressure to the boost compensator.

(b) Measure the injection volume.

Pump rpm	No. of measuring strokes	Injection volume cc (cu. in.)
1,200	200	8.3 - 9.1 (0.51 - 0.56)

(c) Using a screwdriver, adjust the guide bushing.

NOTE: When the guide bushing is turned clockwise, as seen from above, the injection volume will increase.

14. [2L-T] INSPECT BOOST COMPENSATOR CHARACTERISTIC TENDENCY

(a) Apply 0.34 kg/cm² (4.8 psi, 33 kPa) of pressure to the boost compensator.

(b) Measure the injection volume.

Pump rpm	No. of measuring strokes	Injection volume cc (cu. in.)
1,200	200	9.6 - 10.2 (0.59 - 0.62)

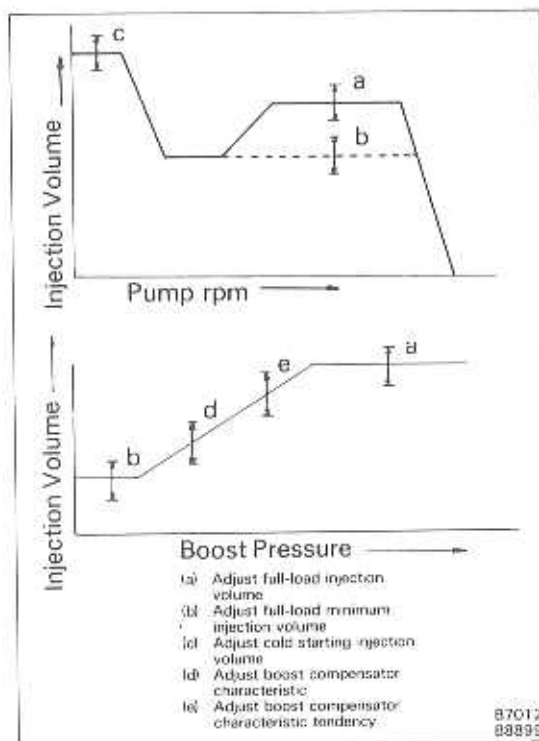

15. [2L-T] CHECK HYSTERESIS

Compare the injection volume when the boost compensator pressure is lowered from 0.88 (12.5 psi, 86 kPa) to 0 kg/cm² and, conversely, when it is raised from zero.

NOTE: Make measurements after moving the adjusting lever between idle and maximum three times for each lowering of the pressure.

Pump rpm	Pressure kg/cm ² (psi, kPa)	No. of measuring strokes	Injection volume cc (cu. in.)	Hysteresis cc (cu. in.)
1,200	0.88 (12.5, 86)	200	7.6 – 9.0 (0.46 – 0.55)	—
1,200	0.61 (8.7, 60)	200	9.9 – 10.5 (0.60 – 0.64)	Less than 0.6 (0.04)
1,200	0.34 (4.8, 33)	200	9.6 – 10.2 (0.59 – 0.62)	—
1,200	0.14 (2.0, 14)	200	8.3 – 9.1 (0.51 – 0.56)	Less than 0.3 (0.02)
1,200	0 (0, 0)	200	7.9 – 8.7 (0.48 – 0.53)	—

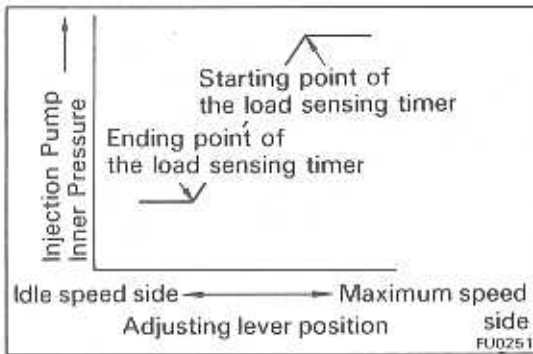

If not within standard valve, check each sliding part of the boost compensator and check whether or not there is any oil.

16. ADJUST LOAD SENSING TIMER

(a) Adjust the starting and ending points of the load sensing timer with the GOVERNOR SHAFT.

(b) (2L-T)

Apply 0.48 kg/cm² (6.8 psi, 47 kPa) of pressure to the boost compensator.

(c) Measure the injection volume.

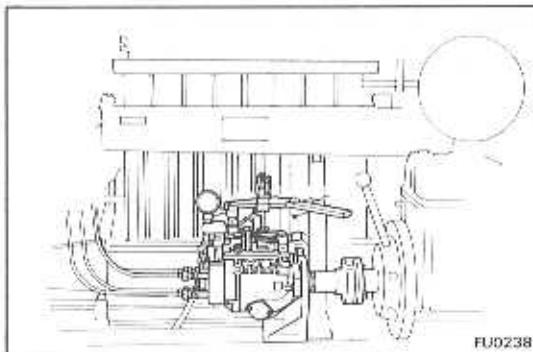

Item	Adjusting lever position	Pump rpm	No. of measuring strokes
L	Maximum speed side	1,200	200
2L		1,200	200
2L-T		1,750	200

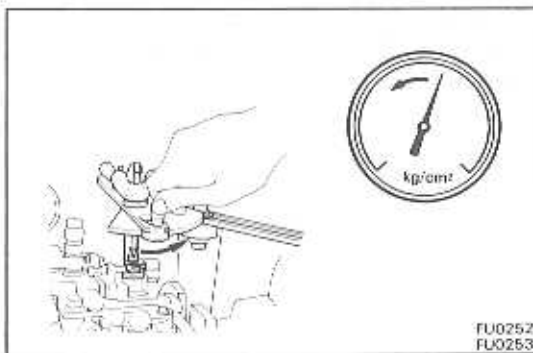

(d) Slowly move the adjusting lever from the maximum speed side to the idle speed side, and secure it at the point where the pump inner pressure begins to drop.

Measure the injection volume at the drop point.

Item	Pump rpm	No. of measuring strokes	Injection volume cc (cu. in.)
L	1,200	200	Measured value at step (c) minus 1.4 (0.09) ± 0.4 (0.02)
2L	1,200	200	
2L-T	1,750	200	

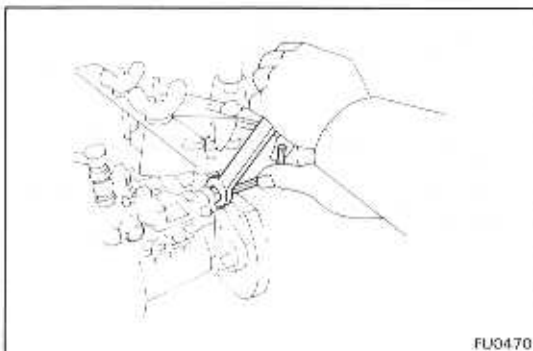

If the injection volume is not within standard, adjust by turning the GOVERNOR SHAFT and perform the measurement (step D) until it is within standard.

NOTE: One-half turn of the governor shaft will alter the injection volume by 3 cc (0.2 cu. in.).

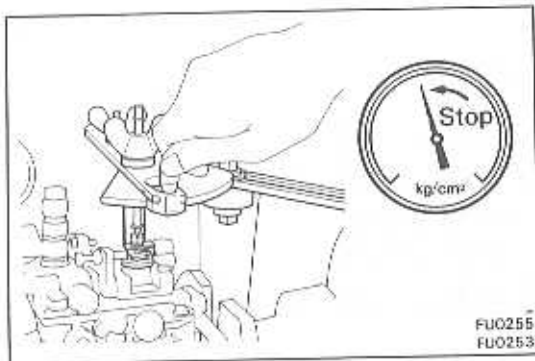

FU0255
FU0253

- (e) Check the ending point injection volume by slowly moving the adjusting lever from the maximum speed side to the idle speed side, and secure it at the point where the pump inner pressure stops dropping.

Item	Pump rpm	No. of measuring strokes	Injection volume cc (cu. in.)
L	1,200	200	2.6 - 3.0 (0.16 - 0.18)
2L	1,200	200	6.2 - 6.6 (0.38 - 0.40)
2L-T	1,750	200	7.3 - 7.7 (0.45 - 0.47)

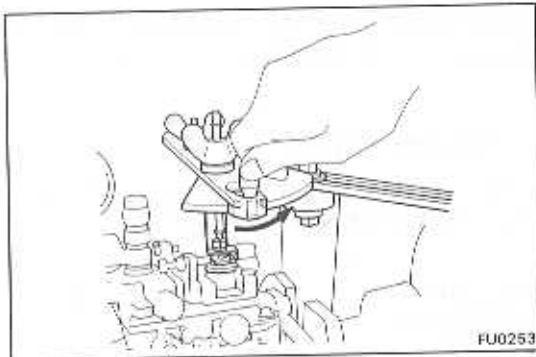

FU0253

- (f) Check the timer piston fluctuation when the adjusting lever is moved from the maximum speed side to the idle speed side.

Item	Pump rpm	Timer piston fluctuation mm (in.)
L w/o HAC	1,200	1.2 - 1.6 (0.047 - 0.063)
2L w/ HAC	1,200	0.8 - 1.2 (0.031 - 0.047)
2L-T	1,750	1.2 - 1.6 (0.047 - 0.063)

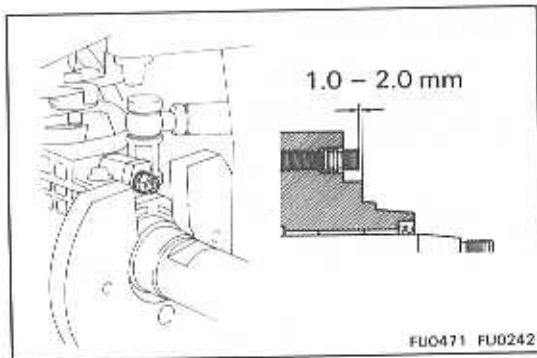

FU0471 FU0242

- (g) Check the protrusion of the governor shaft.
Protrusion: 1.0 - 2.0 mm (0.039 - 0.079 in.)

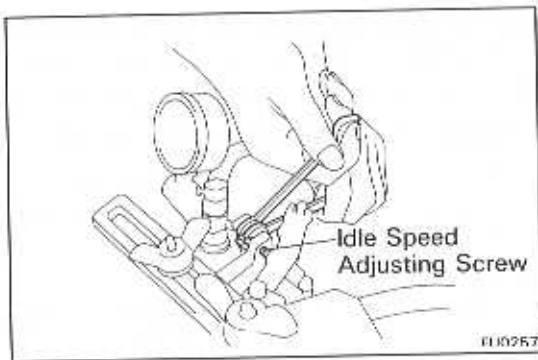

FU0267

17. ADJUST IDLE SPEED

Adjust the injection volume with the IDLE SPEED ADJUSTING SCREW.

Item	Adjusting lever angle	Pump rpm	No. of measuring strokes	Injection volume cc (cu. in.)	Variation limit cc (cu. in.)	Remarks
L	Minus 14.0 - 24.0°	350	200	1.1 - 2.1 (0.07 - 0.13)	-	Adjust
		525	200	Less than 0.3 (0.02)	-	Check

Cont'd

Item	Adjusting lever angle	Pump rpm	No. of measuring strokes	Injection volume cc (cu. in.)	Variation limit cc (cu. in.)	Remarks	
2L	M/T, ex. LX	Minus 12.5 – 22.5°	350	200	1.3 – 2.3 (0.08 – 0.14)	0.34 (0.021)	Adjust
			525	200	Less than 0.3 (0.02)	–	Check
	A/T & LX	Minus 13.5 – 21.5°	400	200	A = 1.3 – 2.3 (0.08 – 0.14)	0.34 (0.021)	Adjust
			375	200	A add 0.36 (0.022)	–	Check
			475	200	A subtract 0.7 – 1.7 (0.04 – 0.10)	–	Check
2L-T	Minus 13.5 – 21.5°	400	200	A = 1.4 – 2.4 (0.09 – 0.15)	0.34 (0.021)	Adjust	
		375	200	A add 0.36 (0.02)	–	Check	
		525	200	A subtract 0.7 – 1.7 (0.04 – 0.10)	–	Check	
		650	200	Less than 0.4 (0.02)	–	Check	

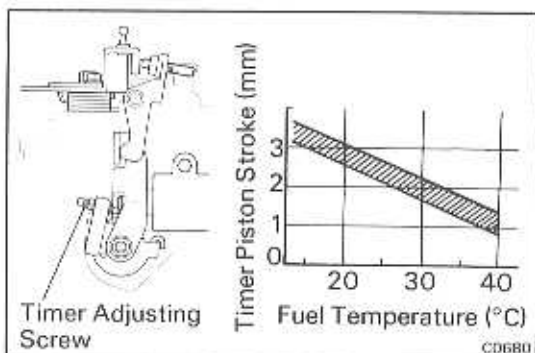
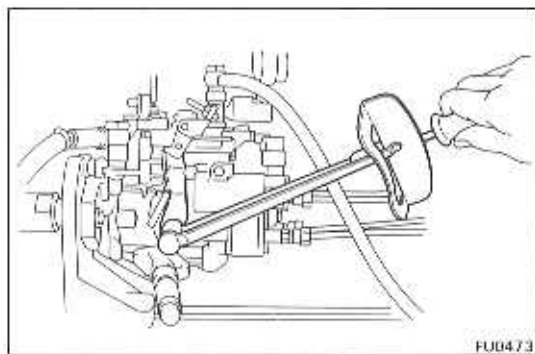
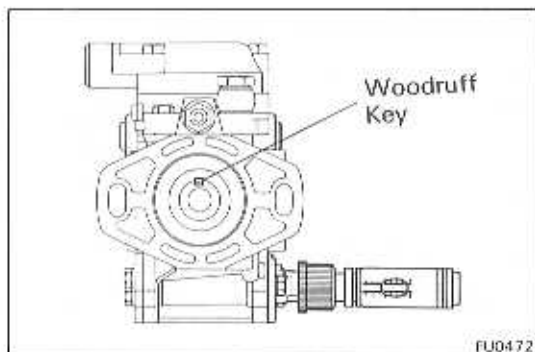

18. [LX]

ADJUST COLD STARTING SYSTEM

(a) Remove the overflow screw and check the fuel temperature in the fuel pump.

Fuel temperature: 15 – 35°C (59 – 95°F)

(b) Set the woodruff key on the pump drive shaft in a vertical or horizontal position.

(c) Set the scale of the timer measuring device to zero.

(d) Check the adjusting lever opening angle and consider this angle as zero.

(e) Remove the metal plate put between the cold starting lever and thermo wax.

(f) Torque the cold starting lever clockwise to approx. 50 kg-cm (43 in.-lb, 4.9 N·m) and keep the lever tightened for about 10 seconds. Then release the torque.

(g) Measure the timer piston stroke.

If not within specification, adjust with the timer adjusting screw.

NOTE: Screw in for stroke decrease.



19. [2L-T] ADJUST FAST IDLE

Measure the clearance between the adjusting lever and idle speed adjusting screw.

Fuel temperature	Clearance
20°C (68°F)	6 mm (0.24 in.)
50°C (122°F)	0 mm (0 in.)

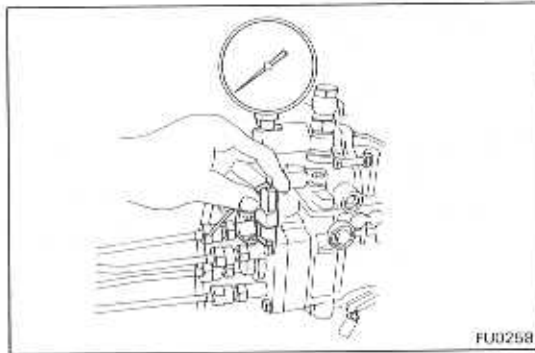

20. POST ADJUSTMENT CHECK

- (a) Check that injection stops when the fuel cut solenoid harness is removed.

Pump revolution: 100 rpm

- (b) Check the idle adjusting lever movement.

Item		Adjusting lever angle
L		30 – 36°
2L 2L-T	2L A/T & LX70	41 – 51°
	2L M/T & LX71 ex. LS Hong Kong & Singapore	43 – 49°
	LS Hong Kong & Singapore	40 – 46°

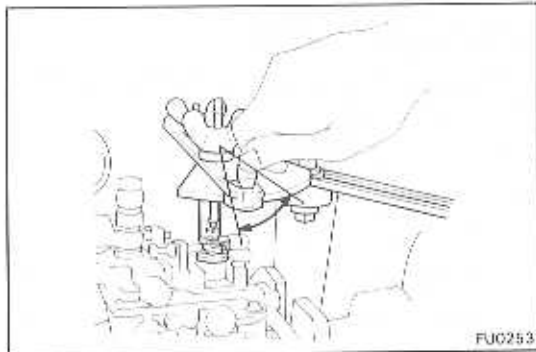

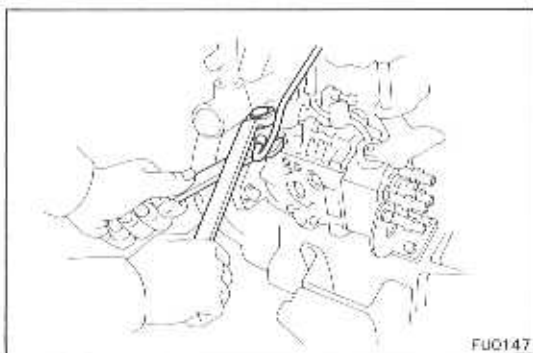
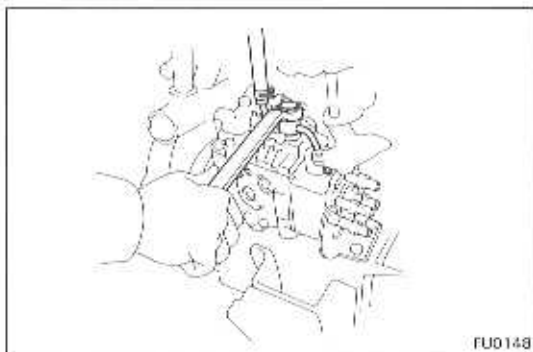
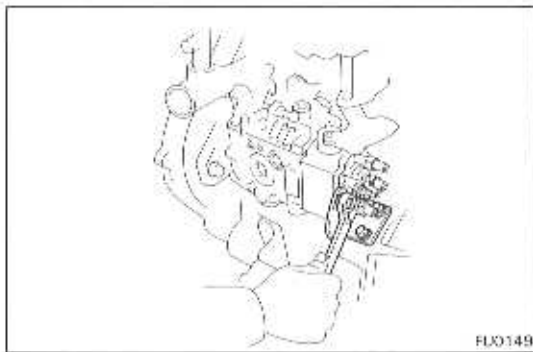
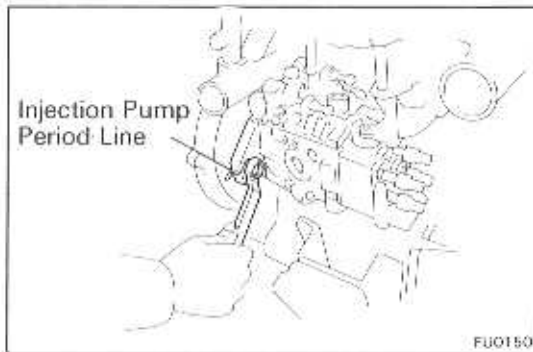

INSTALLATION OF INJECTION PUMP

(See page FU-13)

1. INSTALL INJECTION PUMP

- (a) Align the injection pump period lines on the injection pump and oil pump body.
- (b) Install and torque the two nuts holding the injection pump to the oil pump body.

Torque: 210 kg-cm (15 ft-lb, 21 N·m)

- (c) Install the pump stay with the four bolts. Torque the bolts.

Torque: 185 kg-cm (13 ft-lb, 18 N·m)

2. INSTALL INJECTION PUMP DRIVE PULLEY (See page EM-26)

3. INSTALL TIMING BELT

(See steps 6 to 16 on pages EM-26 to 30)

4. INSTALL FUEL OUTLET PIPE

Install new gaskets and the outlet pipe with the union bolt. Torque the union bolt.

Torque: 230 kg-cm (17 ft-lb, 23 N·m)

5. INSTALL FUEL INLET PIPE

Install new gaskets and the inlet pipe with the union nut. Torque the union nut.

Torque: 230 kg-cm (17 ft-lb, 23 N·m)

6. INSTALL FOUR INJECTION PIPES (See page FU-12)

7. [2L-T]

INSTALL ACCELERATOR LINK

8. [LX]

CONNECT NO. 1 AND NO. 2 WATER BY-PASS HOSES

9. INSTALL ACCELERATOR CONNECTING ROD

10. CONNECT FUEL HOSES TO INLET AND OUTLET FUEL PIPES

11. CONNECT FUEL CUT SOLENOID CONNECTOR

12. CONNECT PICKUP SENSOR CONNECTOR

13. [2L-T]

CONNECT BOOST COMPENSATOR HOSE

14. [LX]

FILL WITH COOLANT

COOLING SYSTEM

	Page
TROUBLESHOOTING	CO-2
CHECK AND REPLACEMENT OF ENGINE COOLANT	CO-3
WATER PUMP	CO-4
THERMOSTAT	CO-7
RADIATOR	CO-8

CO

TROUBLESHOOTING

Problem	Possible cause	Remedy	Page
Engine overheats	Fan belt loose or missing	Adjust or replace belt	CH-5
	Dirt, leaves or insects on radiator or condenser	Clean radiator or condenser	CO-8
	Hoses, water pump, thermostat housing, radiator, heater, core plugs or head gasket leakage	Repair as necessary	
	Thermostat faulty	Check thermostat	CO-7
	Injection timing retarded	Set timing	EM-15
	Fluid coupling faulty	Replace fluid coupling	
	Radiator hose plugged or rotted	Replace hose	
	Water pump faulty	Replace water pump	CO-4
	Radiator plugged or cap faulty	Check radiator	CO-8
	Cylinder head or block cracked or plugged	Repair as necessary	

NOTE: The thermostat on the L, 2L and 2L-T engines is equipped with a by-pass valve. Therefore, if the engine tends to overheat, removal of the thermostat would have an adverse effect, causing a lowering cooling efficiency.

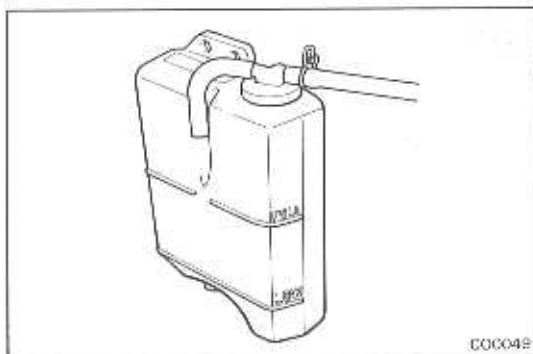

CHECK AND REPLACEMENT OF ENGINE COOLANT

1. CHECK ENGINE COOLANT LEVEL AT RESERVE TANK

The coolant level should be between the "LOW" and "FULL" lines.

If low, check for leaks and add coolant up to the "FULL" line.

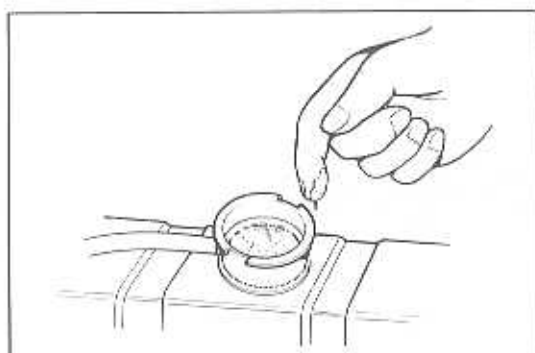

2. CHECK ENGINE COOLANT QUALITY

There should not be any excessive rust deposits or scales around the radiator cap or radiator filler hole, and the coolant should be free from oil.

If excessively dirty, replace the coolant.

3. REPLACE ENGINE COOLANT

- (a) Remove the radiator cap.
- (b) Drain the coolant from radiator and engine drain cocks. (Engine drain cock is at left rear of engine block.)
- (c) Close the drain cocks.

Torque (Engine drain cock):
300 kg-cm (22 ft-lb, 29 N·m)

- (d) Fill the system with coolant.

Use a good brand of ethylene-glycol base coolant, mixed according to the manufacturer's directions.

Capacity (w/ Heater):

LF, LH, LN	10.6 liters (11.2 US qts, 9.3 Imp.qts)
LS	8.8 liters (9.3 US qts, 7.7 Imp.qts)
LX	9.0 liters (9.5 US qts, 8.0 Imp.qts)
LY	9.7 liters (10.3 US qts, 8.5 Imp.qts)

- (e) Install the radiator cap.
- (f) Start the engine and check for leaks.
- (g) Recheck the coolant level and refill as necessary.

WATER PUMP COMPONENTS

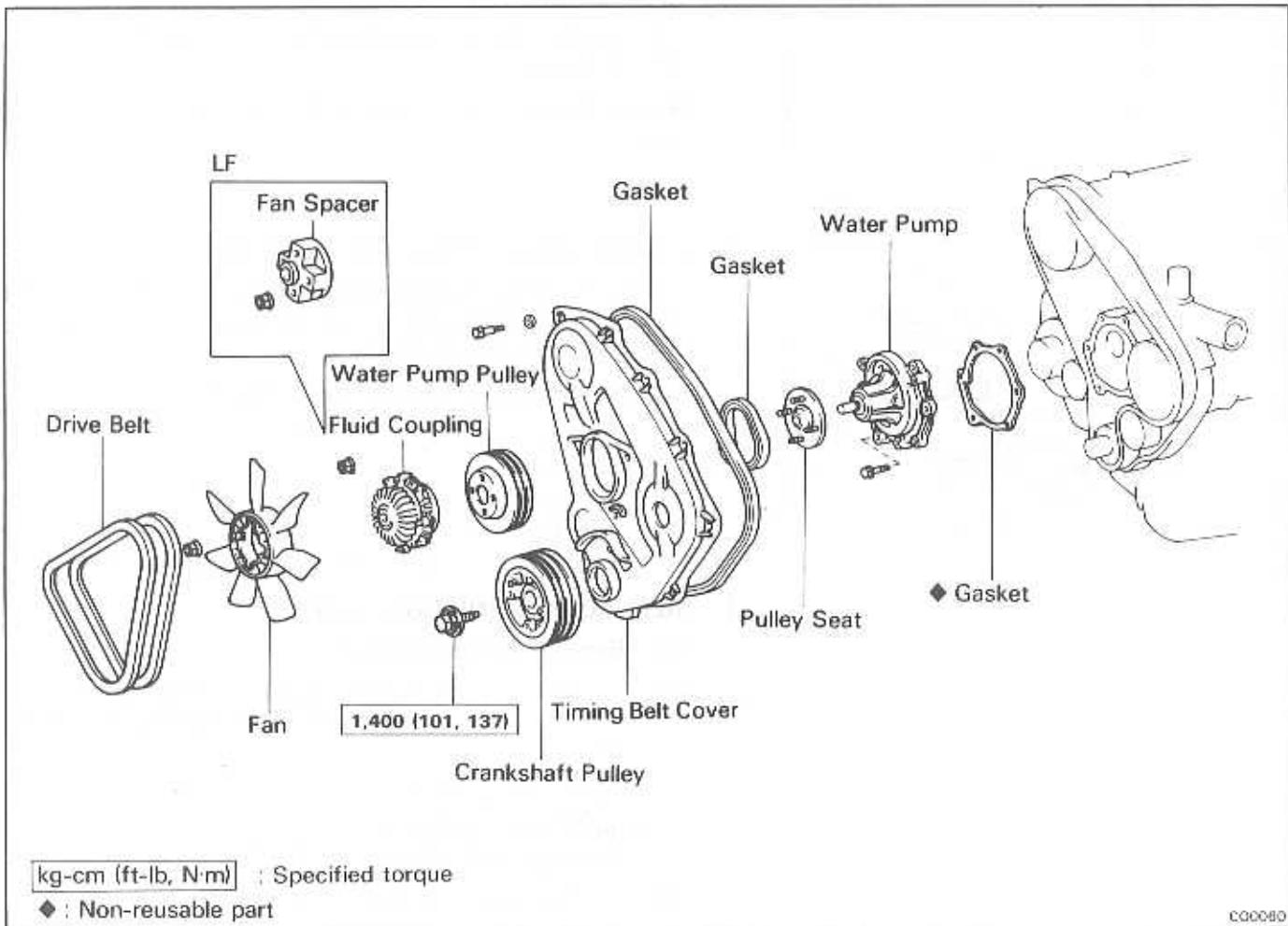

REMOVAL OF WATER PUMP

1. DRAIN COOLANT

Open the radiator and engine drain cocks, and allow the coolant to drain into a suitable container.

2. REMOVE DRIVE BELTS

3. [ex. LF] REMOVE FLUID COUPLING AND WATER PUMP PULLEY WITH FAN

Remove the four nuts mounting the fluid coupling and pulley, and remove the fluid coupling and pulley with the fan.

[LF] REMOVE FAN SPACER AND WATER PUMP PULLEY WITH FAN

Remove the four nuts mounting the spacer and pulley, and remove the spacer and pulley with the fan.

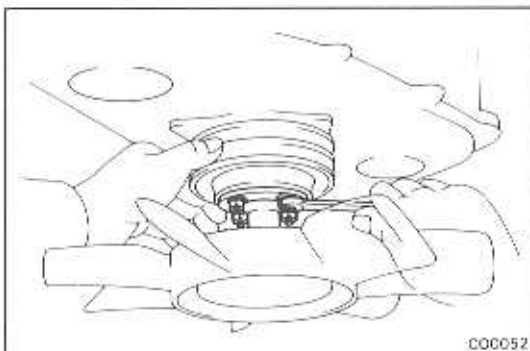

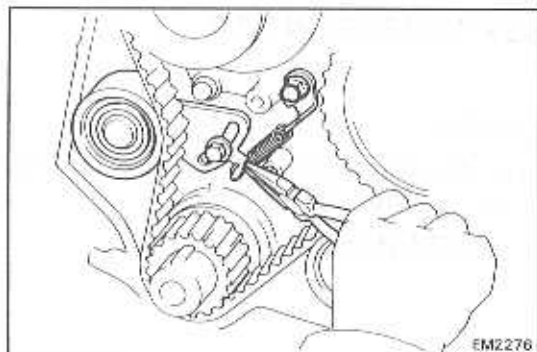

4. REMOVE TIMING BELT COVER
(See steps 1 to 4 on pages EM-20 and 21)

5. REMOVE TIMING BELT TENSION SPRING

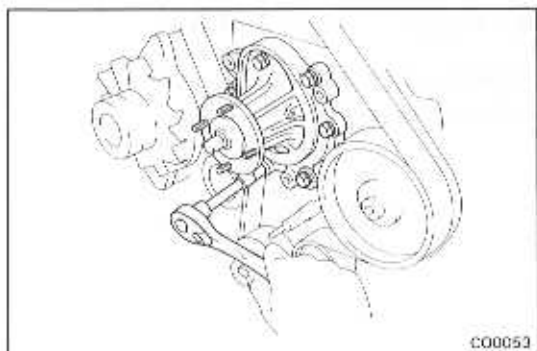

6. REMOVE WATER PUMP

Remove the six bolts, spring bracket, water pump and gasket.

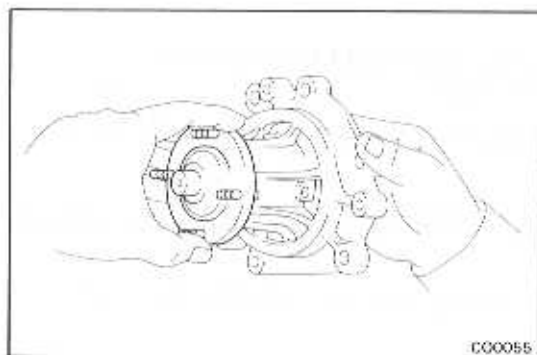

INSPECTION AND REPAIR WATER PUMP

1. INSPECT WATER PUMP BEARING

Check that the water pump bearing operation is not rough or noisy.

If necessary, replace the water pump.

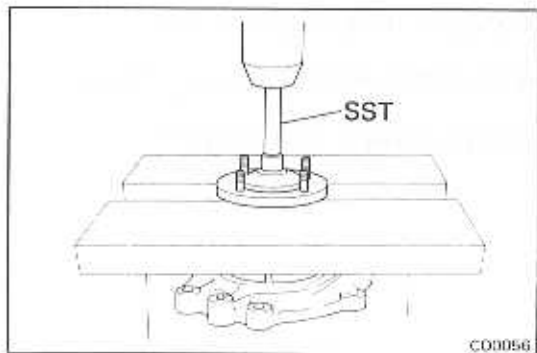

2. IF NECESSARY, REPLACE PULLEY SEAT

(a) Using SST, press out the pulley seat.

SST 09236-00101

(b) Using SST, press in a new pulley seat to specified seat height.

SST 09236-00101

Seat height:

LF 66 mm (2.60 in.)

ex. LF 77 mm (3.03 in.)

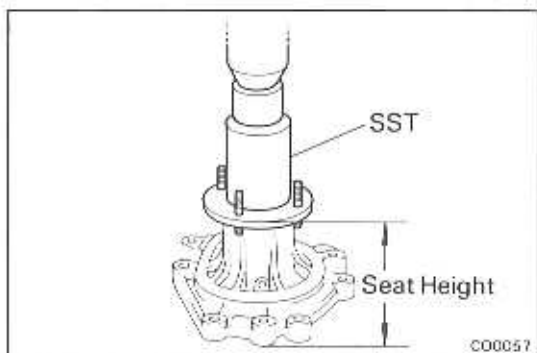

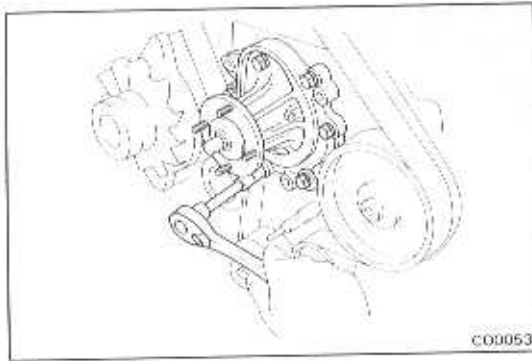

INSTALLATION OF WATER PUMP

(See page CO-4)

1. INSTALL WATER PUMP

Install a new gasket, the water pump and spring bracket with the six bolts. Torque the bolts.

Torque: 195 kg-cm (14 ft-lb, 19 N·m)

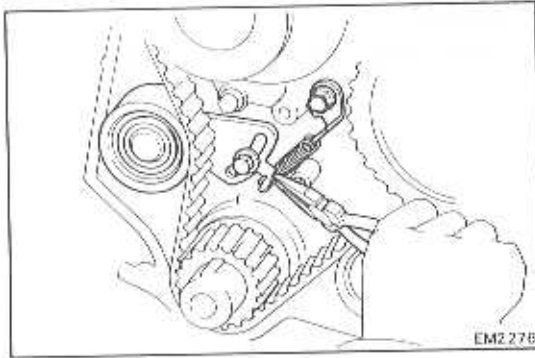

2. INSTALL TIMING BELT TENSION SPRING

3. INSTALL TIMING BELT COVER

(See steps 13, 14 on pages EM-29, 30)

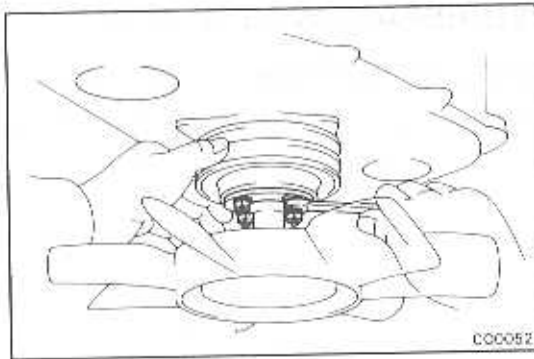

4. [ex. LF]

INSTALL WATER PUMP PULLEY AND FLUID COUPLING WITH FAN

Install the pulley, fluid coupling and fan with the four nuts.

[LF]

INSTALL WATER PUMP PULLEY AND FAN SPACER WITH FAN

Install the pulley, spacer and fan with the four nuts.

5. INSTALL DRIVE BELTS (See page EM-30)

6. FILL ENGINE WITH COOLANT (See page CO-3)

7. START ENGINE AND CHECK FOR LEAKS

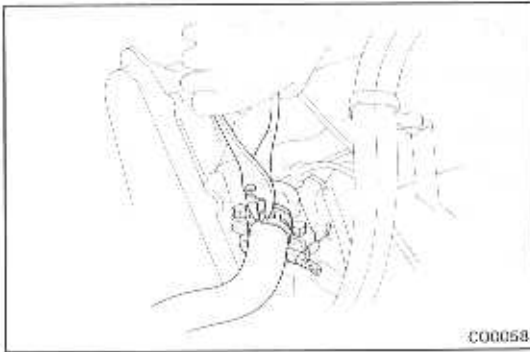

THERMOSTAT

REMOVAL OF THERMOSTAT

1. **DRAIN ENGINE COOLANT** (See page CO-3)
2. **DISCONNECT RADIATOR INLET HOSE FROM WATER OUTLET**
3. **REMOVE WATER OUTLET**
Remove the three bolts, water outlet and gasket.
4. **REMOVE THERMOSTAT**

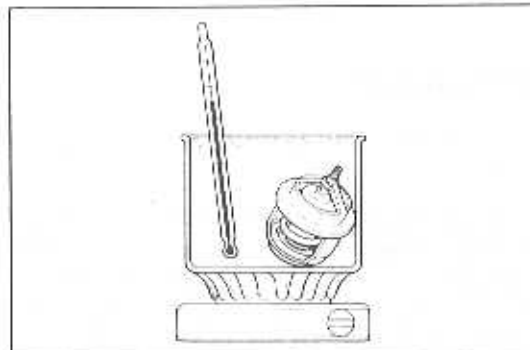
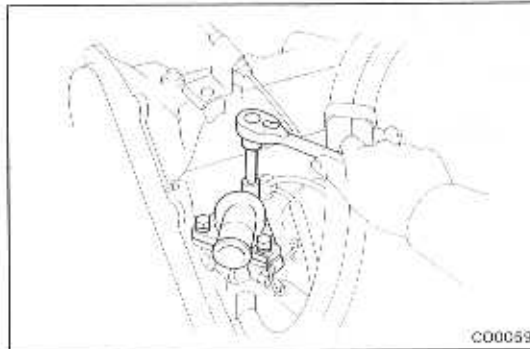

INSPECTION OF THERMOSTAT

NOTE: The thermostat is numbered with the valve opening temperature.

- (a) Immerse the thermostat in water and heat the water gradually.

- (b) Check the valve opening temperature and the valve lift.

If the valve opening temperature and valve lift are not within the following specifications, replace the thermostat.

Valve opening temperature: 86 – 90°C
(187 – 194°F)

Valve lift:

More than 8 mm (0.31 in.) at 100°C (212°F)

- (c) Check that the valve spring is tight when the thermostat is fully closed.

If not closed, replace the thermostat.

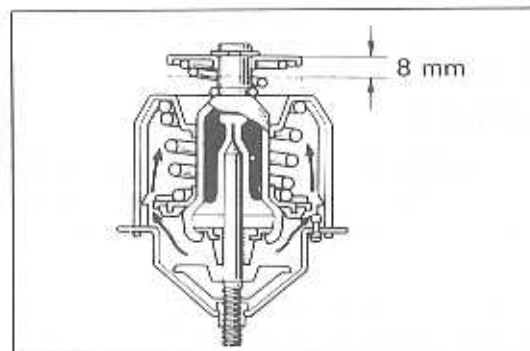

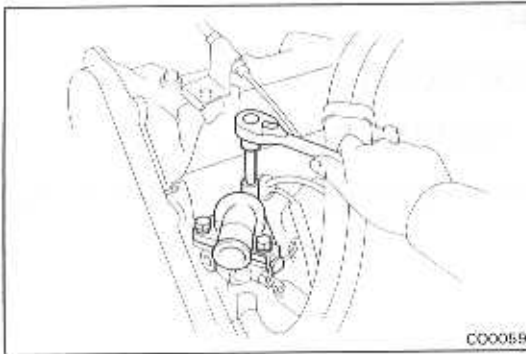

INSTALLATION OF THERMOSTAT

1. PLACE THERMOSTAT IN WATER OUTLET
2. INSTALL WATER OUTLET

Install a new gasket and the water outlet with the three bolts. Torque the bolts.

Torque: 195 kg-cm (14 ft-lb, 19 N·m)

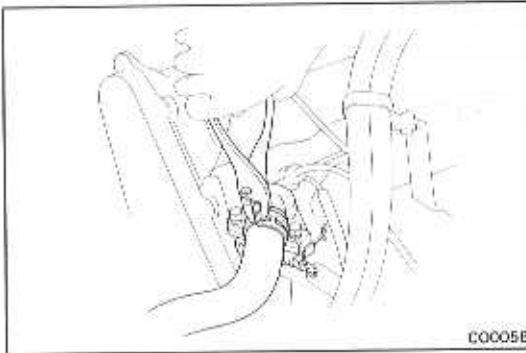

3. CONNECT RADIATOR INLET HOSE
4. FILL ENGINE WITH COOLANT (See page CO-3)
5. START ENGINE AND CHECK FOR LEAKS

RADIATOR

CLEANING OF RADIATOR

Using water or a steam cleaner, remove any mud or dirt from the radiator core.

CAUTION: If using a high pressure type cleaner, be careful not to deform the fins of the radiator core. If the cleaner nozzle pressure is 30 – 35 kg/cm² (427 – 498 psi, 2,942 – 3,432 kPa), keep a distance of at least 40 – 50 cm (15.75 – 19.69 in.) between the radiator core and cleaner nozzle.

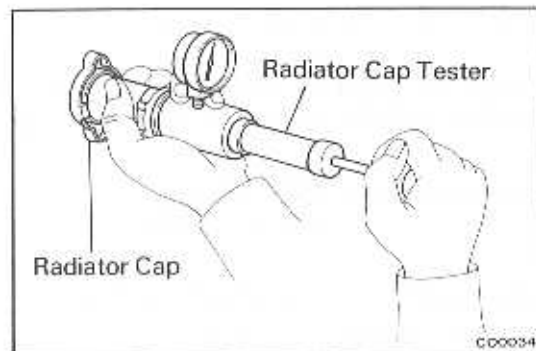

INSPECTION OF RADIATOR

1. CHECK RADIATOR CAP

Using a radiator cap tester, pump the tester until the relief valve opens. Check that the valve opens between 0.75 kg/cm² (10.7 psi, 74 kPa) and 1.05 kg/cm² (14.9 psi, 103 kPa).

Check that the pressure does not drop rapidly when pressure on the cap is below 0.6 kg/cm² (8.5 psi, 59 kPa). If either check is not within limits, replace the cap.

2. CHECK COOLING SYSTEM FOR LEAKS

Attach a radiator cap tester to the radiator, and pump the tester to 0.9 kg/cm² (12.8 psi, 88 kPa). Check that pressure does not drop.

If the pressure drops, check for leaks from the hoses, radiator or water pump. If no external leaks are found, check the heater core, block and head.

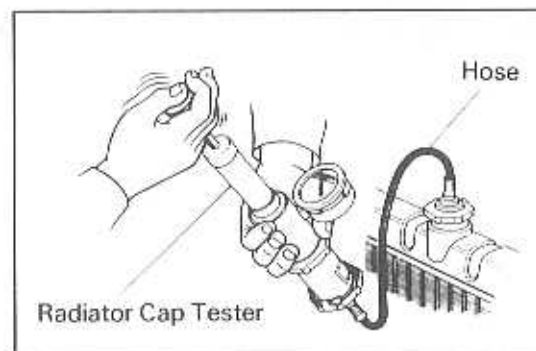

LUBRICATION SYSTEM

	Page
TROUBLESHOOTING	LU-2
OIL PRESSURE CHECK	LU-2
REPLACEMENT OF ENGINE OIL AND OIL FILTER	LU-3
OIL PUMP	LU-4
OIL COOLER AND RELIEF VALVES	LU-8

TROUBLESHOOTING

Problem	Possible cause	Remedy	Page
Oil leakage	Cylinder head, cylinder block or oil pump body damaged or cracked	Repair as necessary	EM-63 LU-4
	Oil seal faulty	Replace oil seal	
	Gasket faulty	Replace gasket	
Low oil pressure	Oil leakage	Repair as necessary	LU-8 LU-4 LU-3 EM-50 EM-50 LU-3
	Relief valve faulty	Repair relief valve	
	Oil pump faulty	Repair oil pump	
	Poor engine oil quality	Replace engine oil	
	Crankshaft bearing faulty	Replace bearing	
	Connecting rod bearing faulty	Replace bearing	
	Oil filter clogged	Replace oil filter	
High oil pressure	Relief valve faulty	Repair relief valve	LU-8

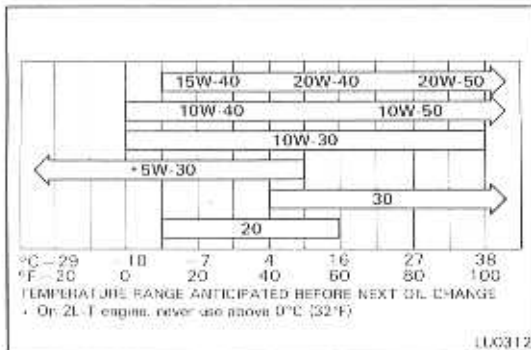

OIL PRESSURE CHECK

1. CHECK OIL QUALITY

Check the oil for deterioration, entry of water, discoloring or thinning.

If the oil quality is poor, replace it.

Use API grade CC, CD (L, 2L), CD (2L-T) or better and recommended viscosity oil.

NOTE: Be sure to use CD type for the vehicle with turbocharger.

2. CHECK OIL LEVEL

The oil level should be between the "L" and "F" marks on the level gauge.

If low, check for leakage and add oil up to the "F" mark.

3. REMOVE OIL PRESSURE SWITCH

4. INSTALL OIL PRESSURE GAUGE

5. START ENGINE

Start the engine and warm it up to normal operating temperature.

6. MEASURE OIL PRESSURE

Oil pressure:

At idle More than 0.3 kg/cm² (4.3 psi, 29 kPa)

At 3,000 rpm 2.5 – 6.0 kg/cm²
(36 – 85 psi, 245 – 588 kPa)

NOTE: Check for oil leakage after reinstalling the pressure switch.

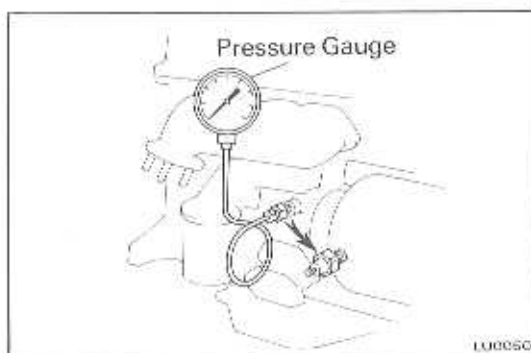

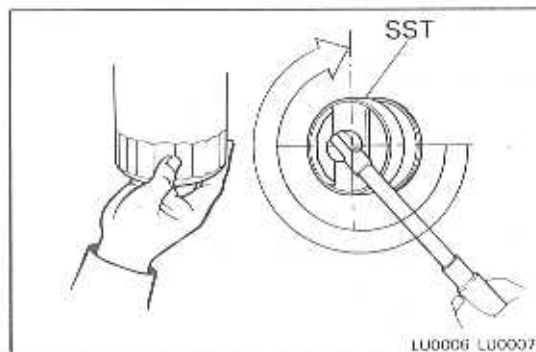
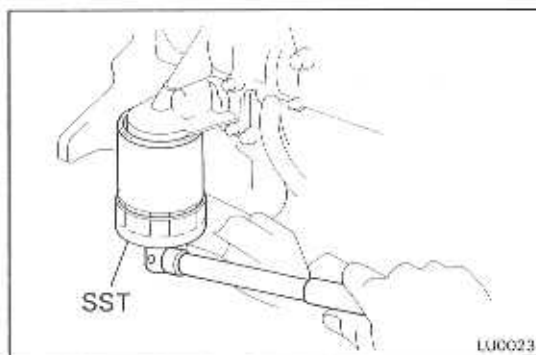

REPLACEMENT OF ENGINE OIL AND OIL FILTER

1. DRAIN ENGINE OIL

- (a) Remove the oil filler cap.
- (b) Remove the oil drain plug and drain the oil into a container.

2. REPLACE OIL FILTER

- (a) Using SST, remove the oil filter.
SST 09228-44010
- (b) Inspect and clean the oil filter installation surface.
- (c) Apply clean engine oil to the gasket of a new oil filter.

- (d) Lightly screw in the oil filter to where you feel resistance.
- (e) Then, using SST, tighten the oil filter an extra 3/4 turn.

SST 09228-44010

3. FILL WITH ENGINE OIL

- (a) Clean and install the oil drain plug with a new gasket. Torque the drain plug.

Torque: 175 kg-cm (13 ft-lb, 17 N·m)

- (b) Fill the engine with new oil, API grade CC, CD (L, 2L), CD (2L-T) or better.

Capacity:

Drain and refill—

w/o Oil filter change

4.8 liters (5.1 US qts, 4.2 Imp.qts)

w/ Oil filter change

5.8 liters (6.1 US qts, 5.1 Imp.qts)

Dry fill— 6.5 liters (6.9 US qts, 5.7 Imp.qts)

- (c) Install the oil filler cap with the gasket.

4. START ENGINE AND CHECK FOR LEAKS

5. RECHECK OIL LEVEL

Recheck the engine oil level and refill as necessary.

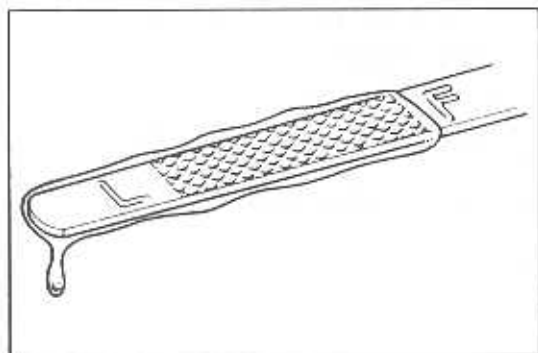

OIL PUMP COMPONENTS

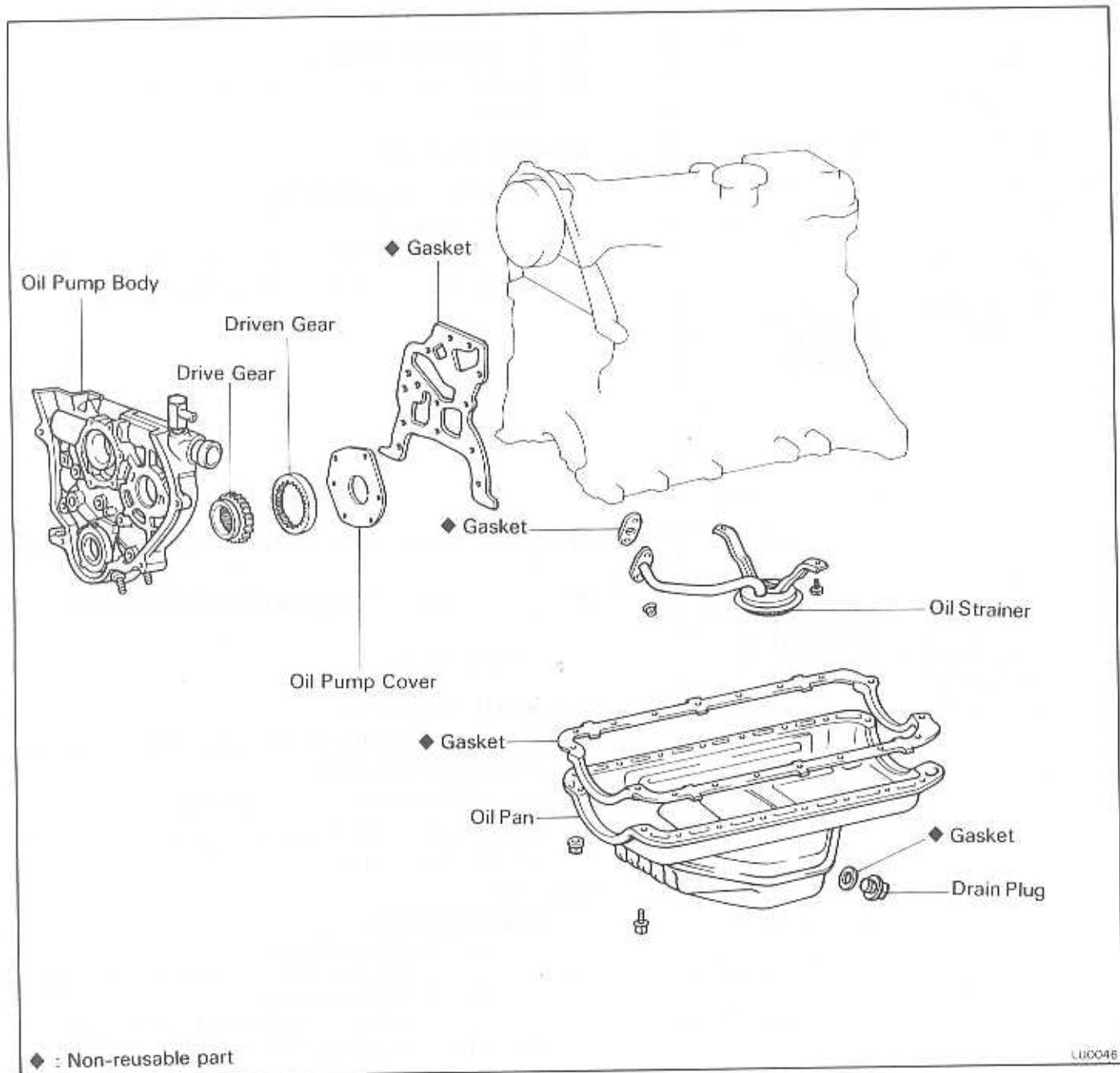

REMOVAL AND DISASSEMBLY OF OIL PUMP

NOTE: If repairing the oil pump, the oil pan and oil strainer should be removed and cleaned.

1. **REMOVE TIMING BELT**
(See steps 1 to 9 and 11 to 13 on pages EM-20 to 23)
2. **REMOVE WATER PUMP** (See page CO-5)
3. **DRAIN ENGINE OIL**

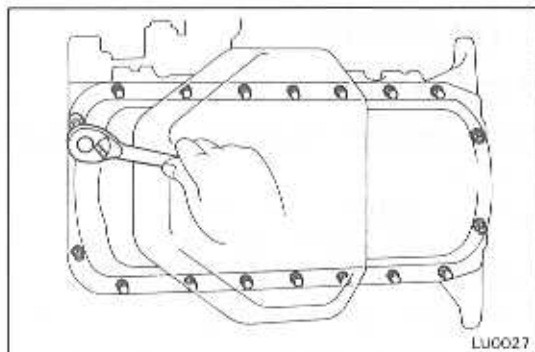
**4. REMOVE OIL PAN**

Remove the fourteen bolts, four nuts, oil pan and gasket.

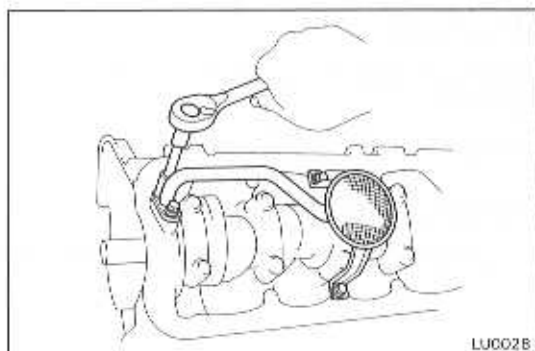
**5. REMOVE OIL STRAINER**

Remove the two bolts, two nuts, oil strainer and gasket.

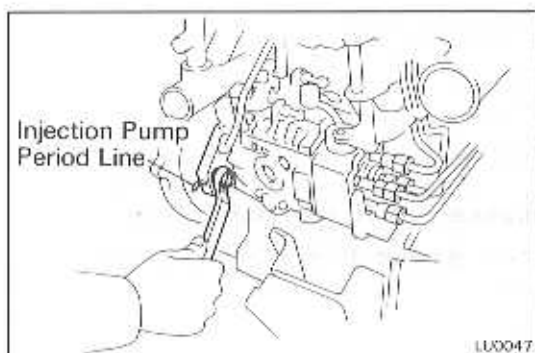
6. REMOVE TIMING POINTER FROM OIL PUMP BODY**7. REMOVE OIL PUMP ASSEMBLY**

(a) Check the position of the injection period line before removing the two nuts holding the injecting pump to the oil pump body.

(b) Remove the five bolts, oil pump assembly and gasket.

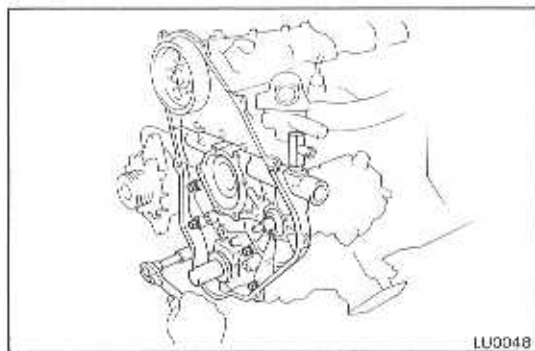
**8. DISASSEMBLE OIL PUMP ASSEMBLY**

Remove the six bolts, oil pump cover, drive and driven gears from the oil pump body.

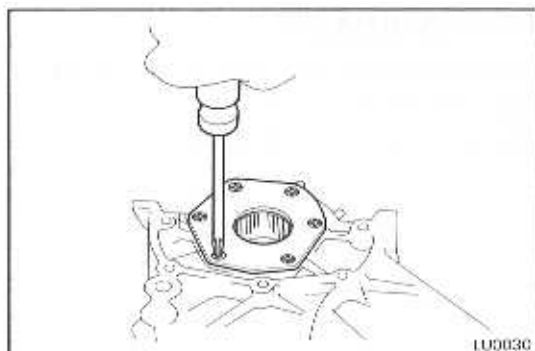

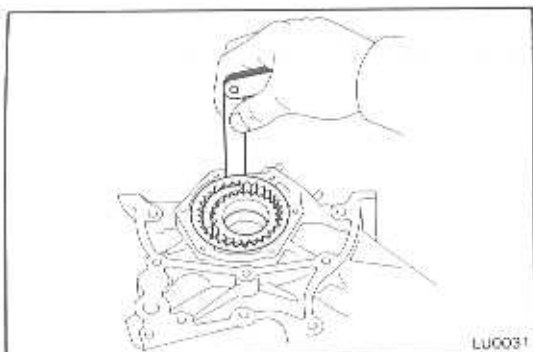

INSPECTION OF OIL PUMP

1. INSPECT BODY CLEARANCE

Using a feeler gauge, measure the clearance between the driven gear and body.

Standard clearance: 0.06 – 0.15 mm
(0.0024 – 0.0059 in.)

Maximum clearance: 0.20 mm (0.0079 in.)

If the clearance is greater than maximum, replace the gear and/or body.

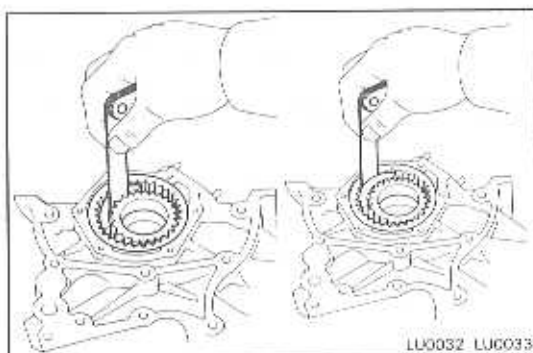

2. INSPECT TIP CLEARANCE

Using a feeler gauge, measure the clearance between both gear tips and crescent.

Standard clearance: 0.15 – 0.21 mm
(0.0059 – 0.0083 in.)

Maximum clearance: 0.30 mm (0.0118 in.)

If the clearance is greater than maximum, replace the gear and/or body.

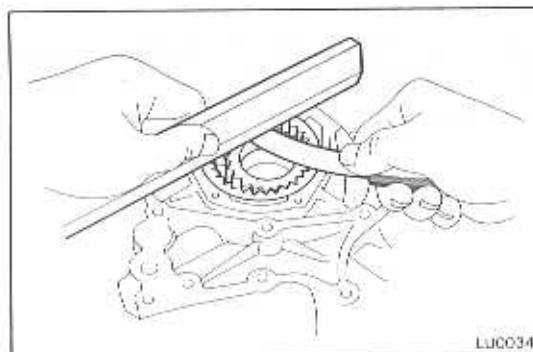

3. INSPECT SIDE CLEARANCE

Using a feeler gauge and flat block, measure the side clearance as shown.

Standard clearance: 0.03 – 0.09 mm
(0.0012 – 0.0035 in.)

Maximum clearance: 0.15 mm (0.0059 in.)

If the clearance is greater than maximum, replace the gears and/or body.

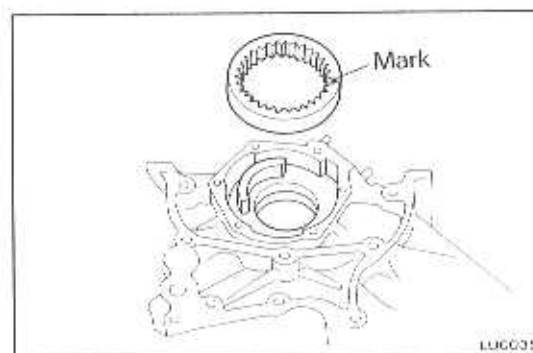

ASSEMBLY AND INSTALLATION OF OIL PUMP

(See page LU-4)

1. ASSEMBLE OIL PUMP ASSEMBLY

- (a) Put the drive and driven gears into the oil pump body with the marks facing the oil pump cover side.
- (b) Install the oil pump cover with the six screws.

2. INSTALL OIL PUMP ASSEMBLY

- (a) Install a new gasket and the oil pump assembly with the five bolts. Torque the bolts.

Torque: 195 kg-cm (14 ft-lb, 19 N·m)

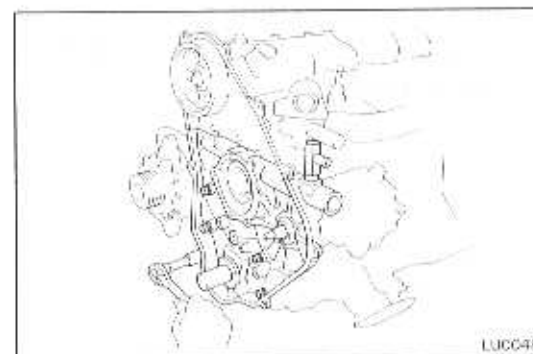

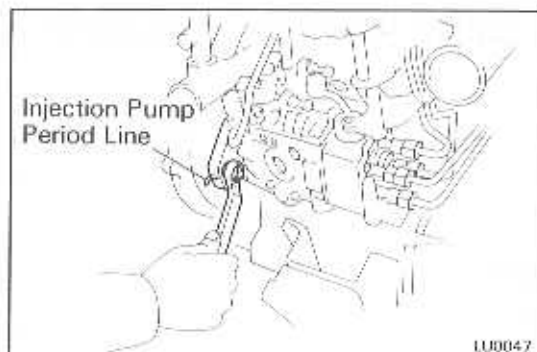

- (b) Install the two nuts holding the injection pump to the oil pump body. Torque the nuts.

Torque: 210 kg-cm (15 ft-lb, 21 N·m)

- (c) Check the position of the injection period line.

If not correct, adjust the injection period line by tilting the injection pump.

3. INSTALL TIMING POINTER

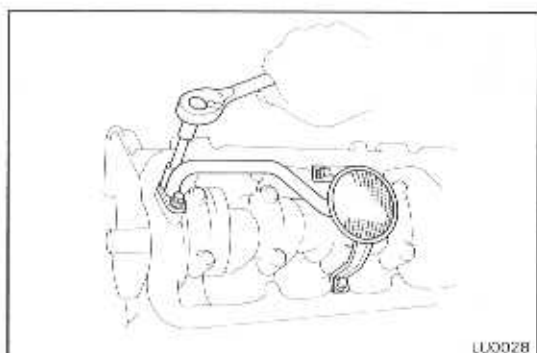

4. INSTALL OIL STRAINER

Install a new gasket and the oil strainer with the two bolts and nuts. Torque the bolts and nuts.

Torque: 120 kg-cm (9 ft-lb, 12 N·m)

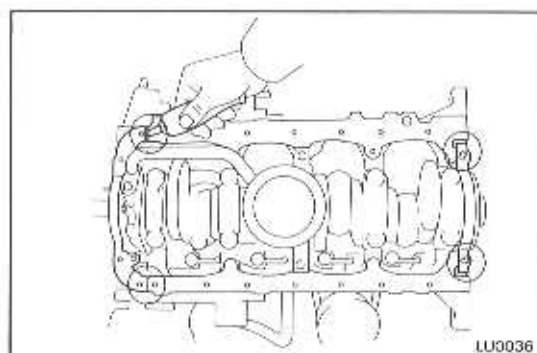

5. INSTALL OIL PAN

- (a) Apply seal packing black (Part No. 08826-00080) or equivalent to the oil pump body, cylinder block and rear oil seal retainer as shown.

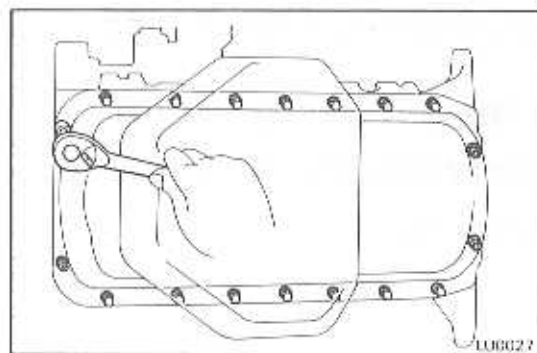

- (b) Install a new gasket and the oil pan with the fourteen bolts and four nuts.

Torque:

Bolts 80 kg-cm (69 in.-lb, 8 N·m)

Nuts 175 kg-cm (13 ft-lb, 17 N·m)

6. INSTALL WATER PUMP (See page CO-6)

7. INSTALL TIMING BELT

(See steps 1 to 3 and 5 to 16 on pages EM-25 to 30)

8. FILL WITH ENGINE OIL (See page LU-3)

9. FILL ENGINE WITH COOLANT (See page CO-3)

10. START ENGINE AND CHECK FOR LEAKS

OIL COOLER AND RELIEF VALVES COMPONENTS

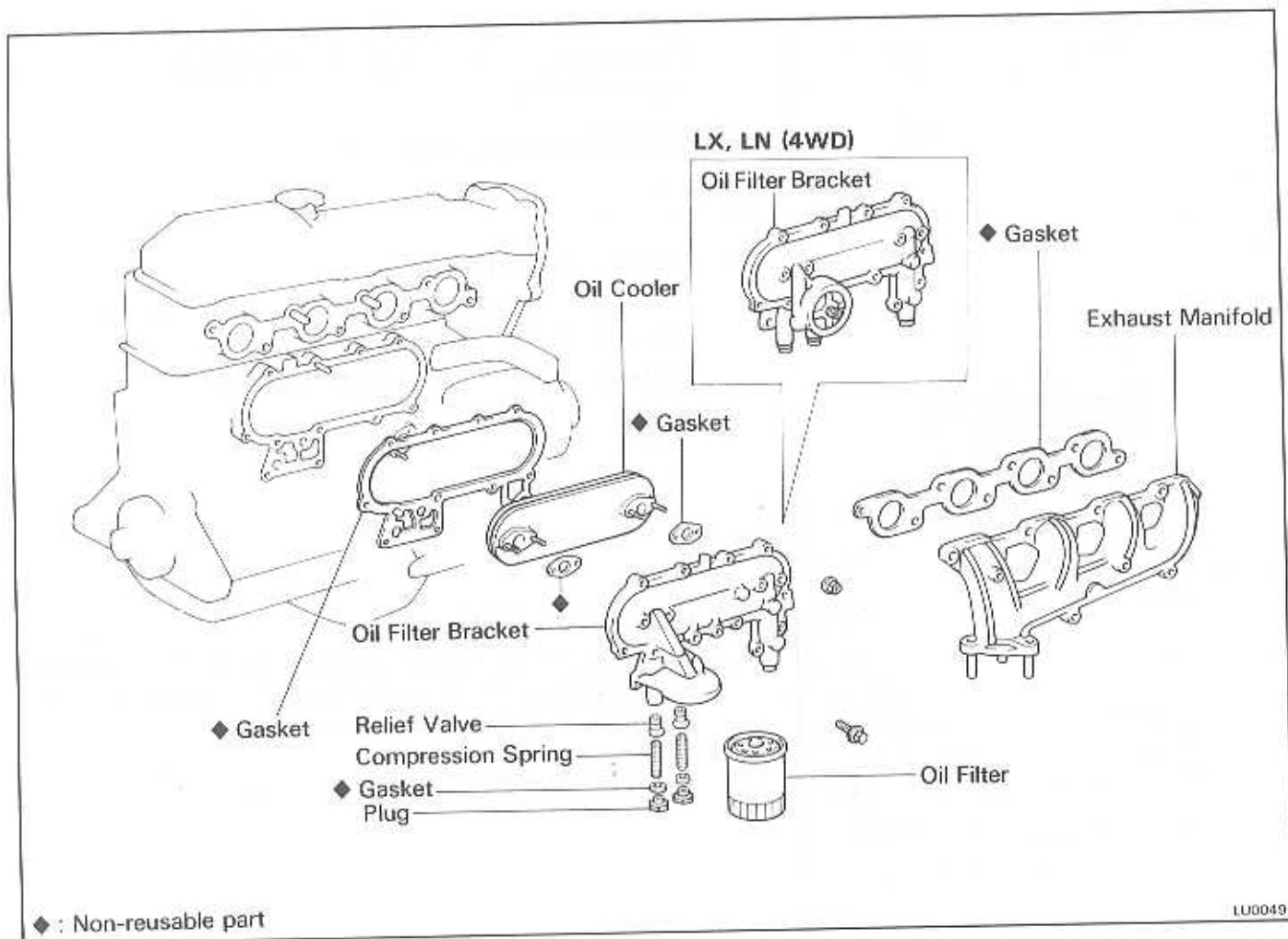

REMOVAL OF OIL COOLER AND RELIEF VALVE

1. DRAIN ENGINE COOLANT (See page CO-3)
2. REMOVE EXHAUST MANIFOLD (See page EM-33)
3. REMOVE OIL FILTER (See page LU-3)
4. REMOVE TWO RELIEF VALVES
Remove the two plugs, washers, springs and relief valves.
NOTE: Arrange the disassembled parts in order.

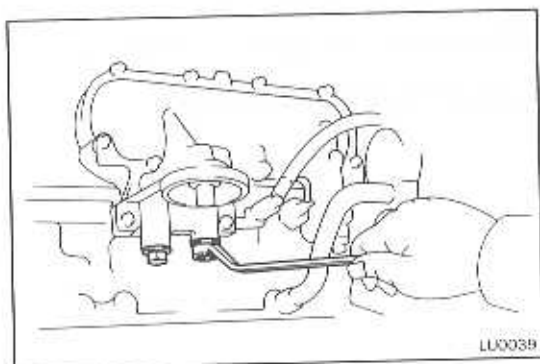

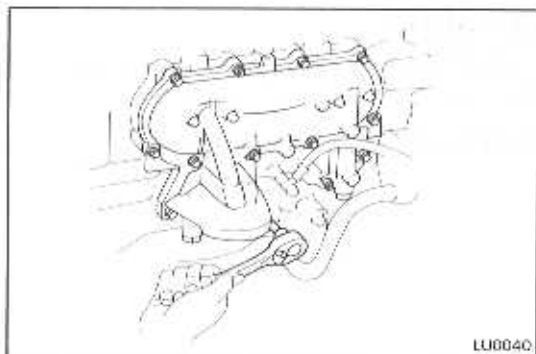

5. REMOVE OIL FILTER BRACKET WITH OIL COOLER

Remove the eleven bolts, two nuts, oil filter bracket and gasket with the oil cooler.

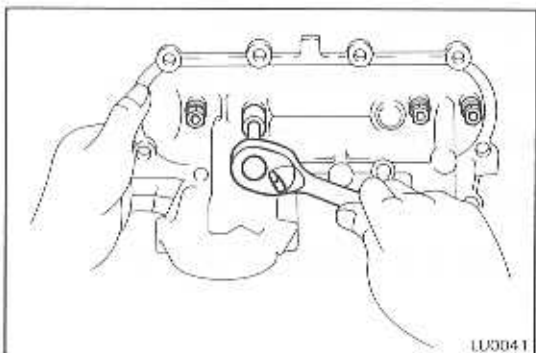

6. REMOVE OIL COOLER FROM OIL FILTER BRACKET

Remove the four nuts, oil cooler and two gaskets.

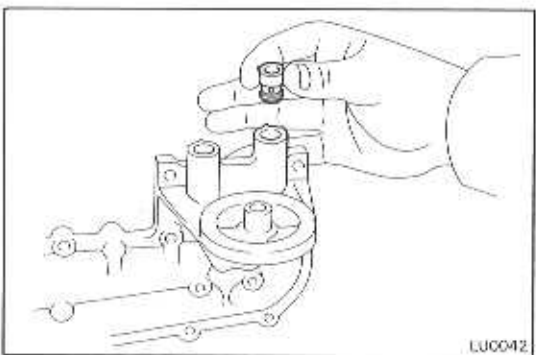

INSPECTION OF COMPONENTS

INSPECT RELIEF VALVE

Coat the valve with engine oil and check that it falls smoothly into the valve hole by its own weight.

If necessary, replace the valve and/or oil filter bracket.

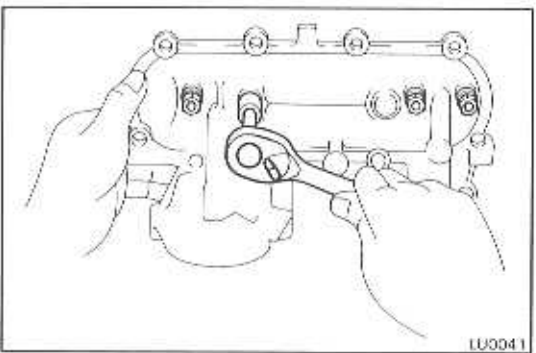

INSTALLATION OF OIL COOLER AND RELIEF VALVE

(See page LU-8)

1. INSTALL OIL COOLER TO OIL FILTER BRACKET

Install two new gaskets and the oil cooler with the four nuts. Torque the nuts.

Torque: 145 kg-cm (10 ft-lb, 14 N·m)

2. INSTALL OIL FILTER BRACKET AND OIL COOLER ASSEMBLY

Install a new gasket, the oil filter bracket and oil cooler assembly with the ten bolts and three nuts. Torque the bolts and nuts.

Torque: Bolts 195 kg-cm (14 ft-lb, 19 N·m)
Nuts 210 kg-cm (15 ft-lb, 21 N·m)

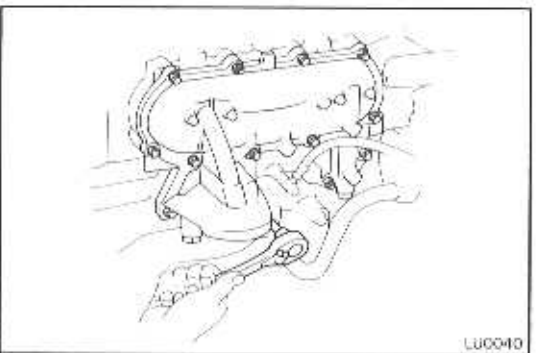

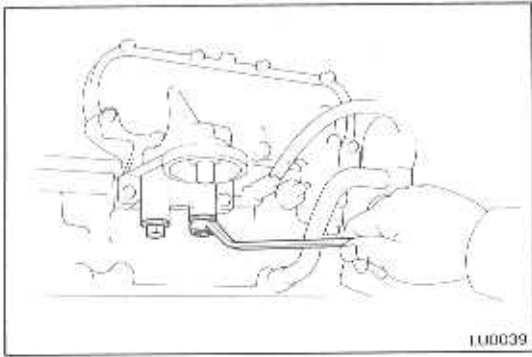
**3. INSTALL RELIEF VALVES**

Install the two relief valves, springs, new gaskets and plugs. Torque the plugs.

Torque: 370 kg-cm (27 ft-lb, 36 N·m)

4. **INSTALL OIL FILTER** (See page LU-3)
5. **INSTALL EXHAUST MANIFOLD** (See page EM-47)
6. **FILL ENGINE WITH COOLANT** (See page CO-3)
7. **START ENGINE AND CHECK FOR LEAKS**
8. **CHECK ENGINE OIL** (See step 5 on page LU-3)

STARTING SYSTEM

	Page
PRE-HEATING SYSTEM	ST-2
TROUBLESHOOTING	ST-14
STARTING SYSTEM CIRCUIT	ST-14
STARTER	ST-15
STARTER RELAY	ST-27

PRE-HEATING SYSTEM

Super Glow Type

[Europe (LH, LX, LN, LJ)]

SYSTEM CIRCUIT

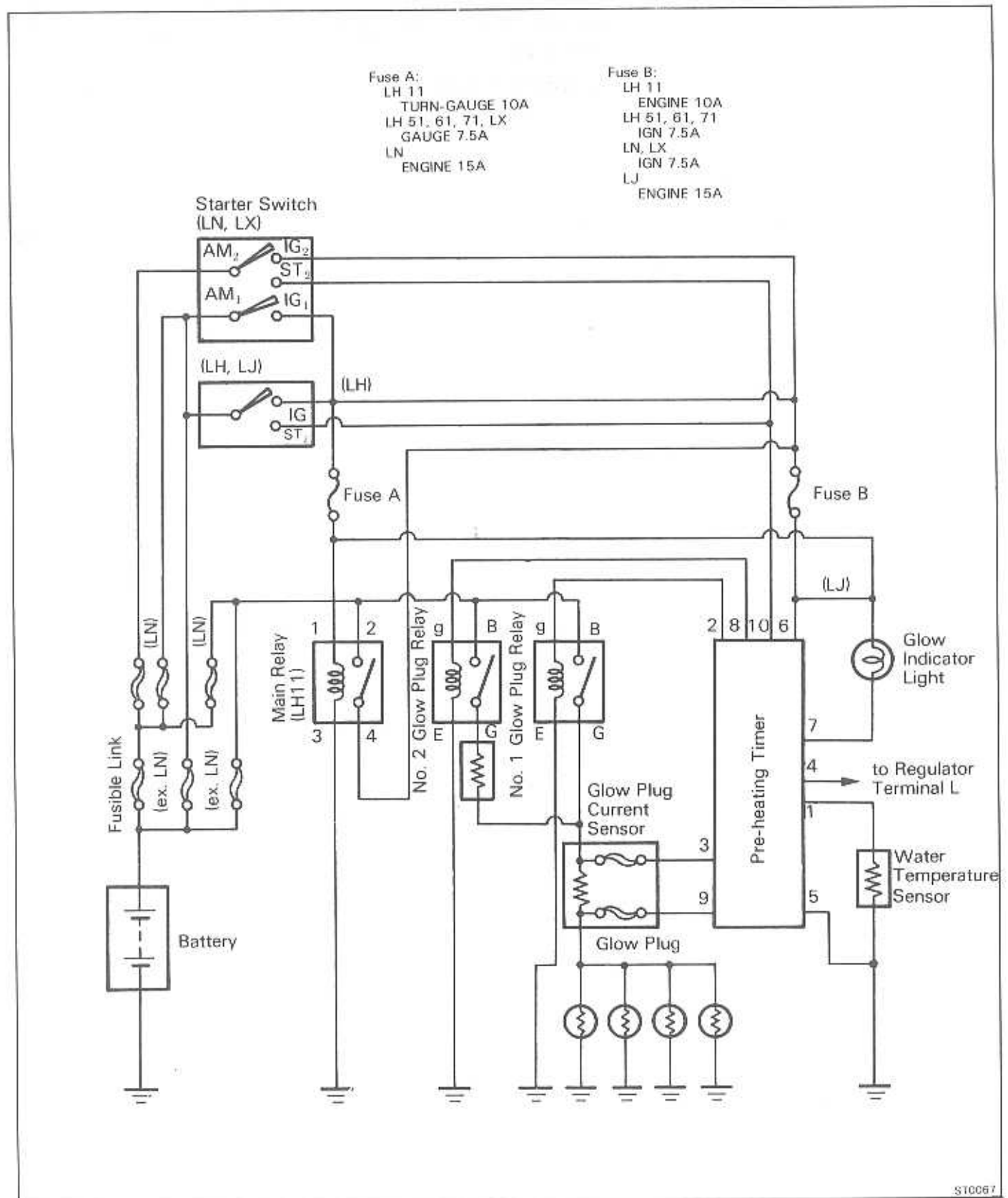

ex, LX

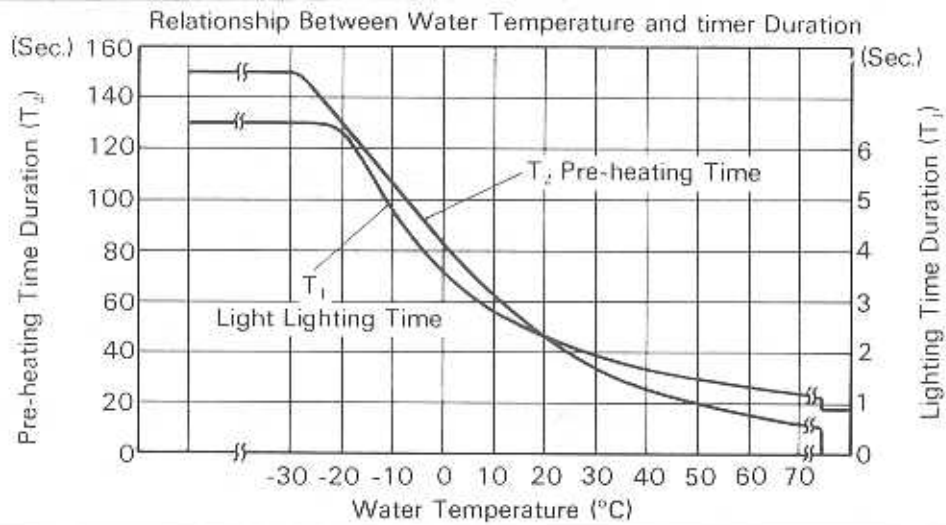

ST0048

LX

Relationship Between Water Temperature and Timer Duration

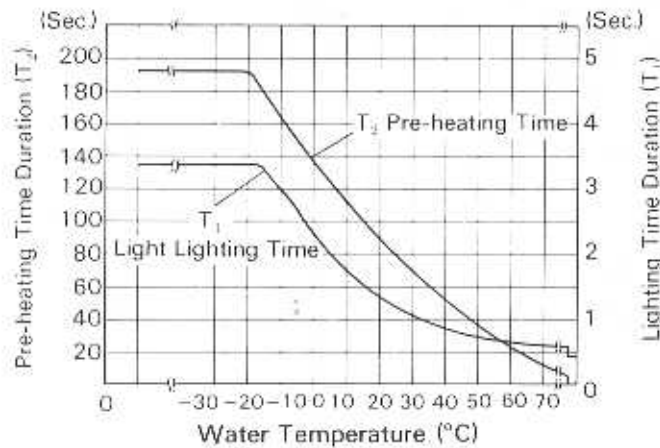

ST0160

LH11, LN, LX, LJ

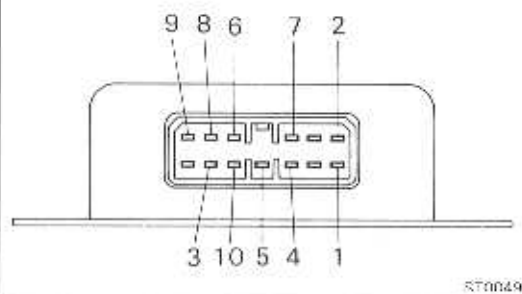

ST0049

INSPECTION OF COMPONENTS

Pre-heating Timer

LOCATION

- LH 11, LX, LJ: Under the instrument panel on the passenger side.
- LH 51, 61, 71: Under the instrument panel center.
- LN: In the left cowl.

LH51, 61, 71

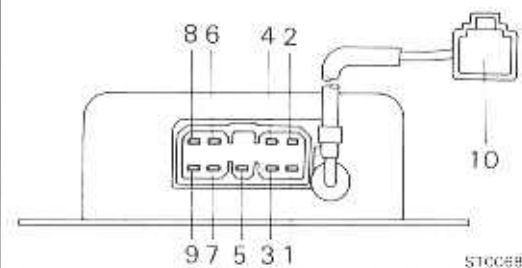

ST0058

Refer to Diesel Electrical System Diagnosis for inspection procedures. (See pages EM-11, 12)

No. 1 and No. 2 Glow Plug Relay

LOCATION

LN, LX: On the left fender apron in the engine compartment.

LH 11, 51, 61, 71 (No. 1): In the engine compartment on the left side.

LH 51, 61, 71 (No. 2): Under the instrument panel on the driver's side.

LH 11 (No. 2): Under the instrument panel on the passenger side.

INSPECT NO. 1 AND NO. 2 GLOW PLUG RELAY

(a) Using an ohmmeter, check for continuity between the following terminals:

- E ↔ g **Continuity**
- B ↔ G **No continuity**

(b) Apply battery voltage between terminals E and g.

- B ↔ G **Continuity**

If continuity is not as specified, replace the relay.

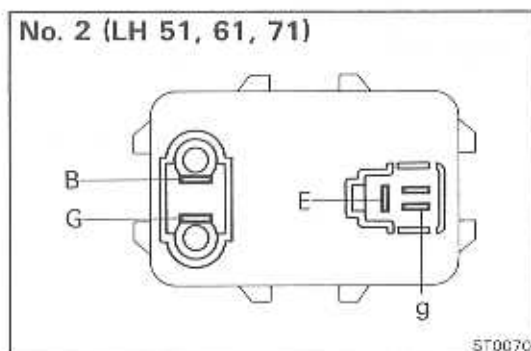
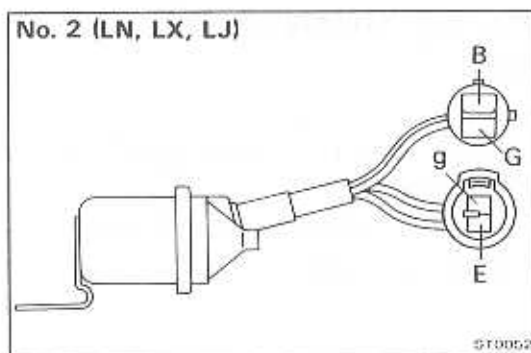
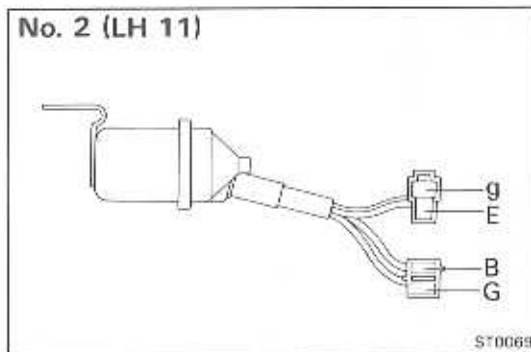
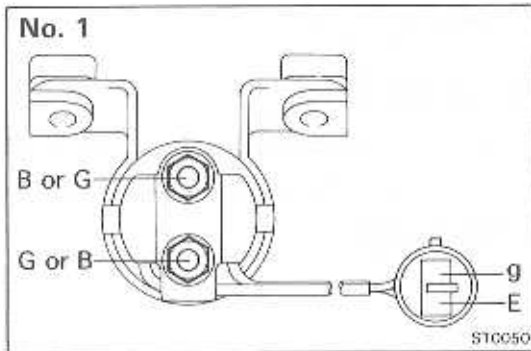

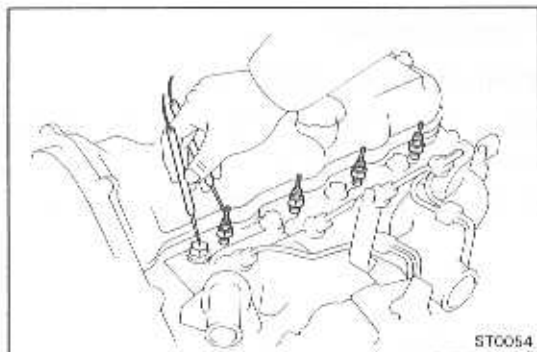

Glow Plug

INSPECT GLOW PLUG

Using an ohmmeter, check that there is continuity between the glow plug terminal and ground.

If there is no continuity, replace the glow plug.

NOTE:

- Be careful not to damage the glow plug pipes as it could cause an open circuit or shorten life of the plugs.
- Avoid getting oil and gasoline on the glow plugs when cleaning.
- During inspection, be sure to wipe any oil off the glow plug terminals and bakelite washer with a dry cloth.
- Be careful not to apply more than 7 volts to the glow plug as it could cause an open circuit.

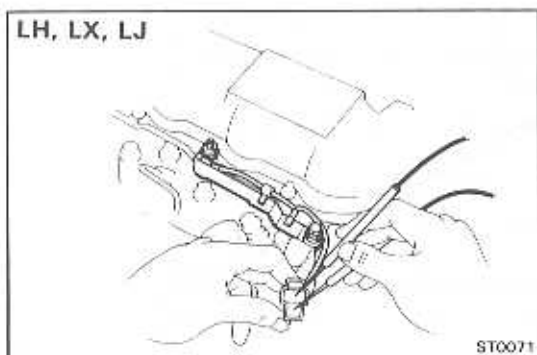
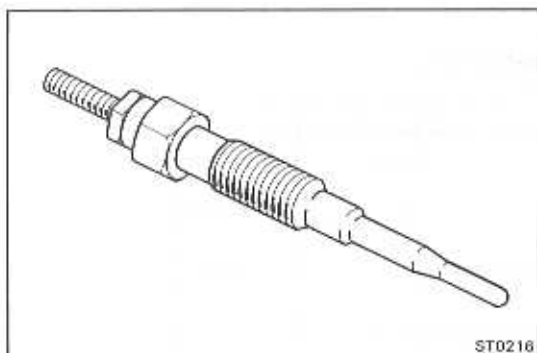

Glow Plug Current Sensor

INSPECT GLOW PLUG CURRENT SENSOR

Using an ohmmeter, check that there is continuity between the current sensor terminals.

If there is no continuity, replace the current sensor.

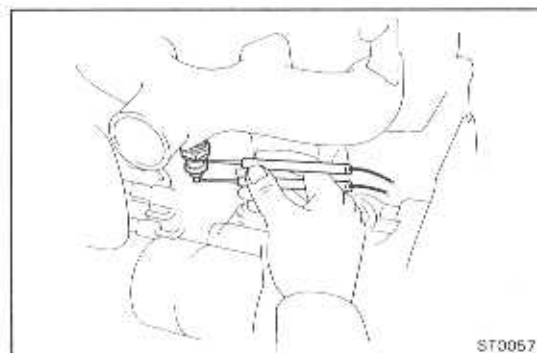
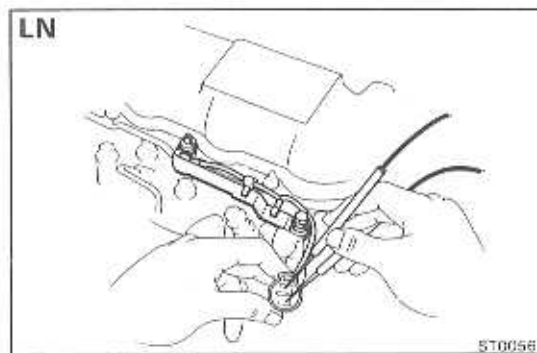

Glow Plug Resistor

INSPECT GLOW PLUG RESISTOR

Using an ohmmeter, check that there is continuity between the resistor terminals.

If there is no continuity, replace the resistor.

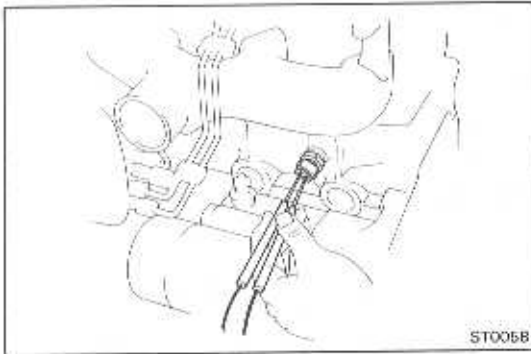

Water Temperature Sensor

INSPECT WATER TEMPERATURE SENSOR

Using an ohmmeter, check the resistance between the water temperature sensor terminals.

If the resistance is not as specified, replace the water temperature sensor.

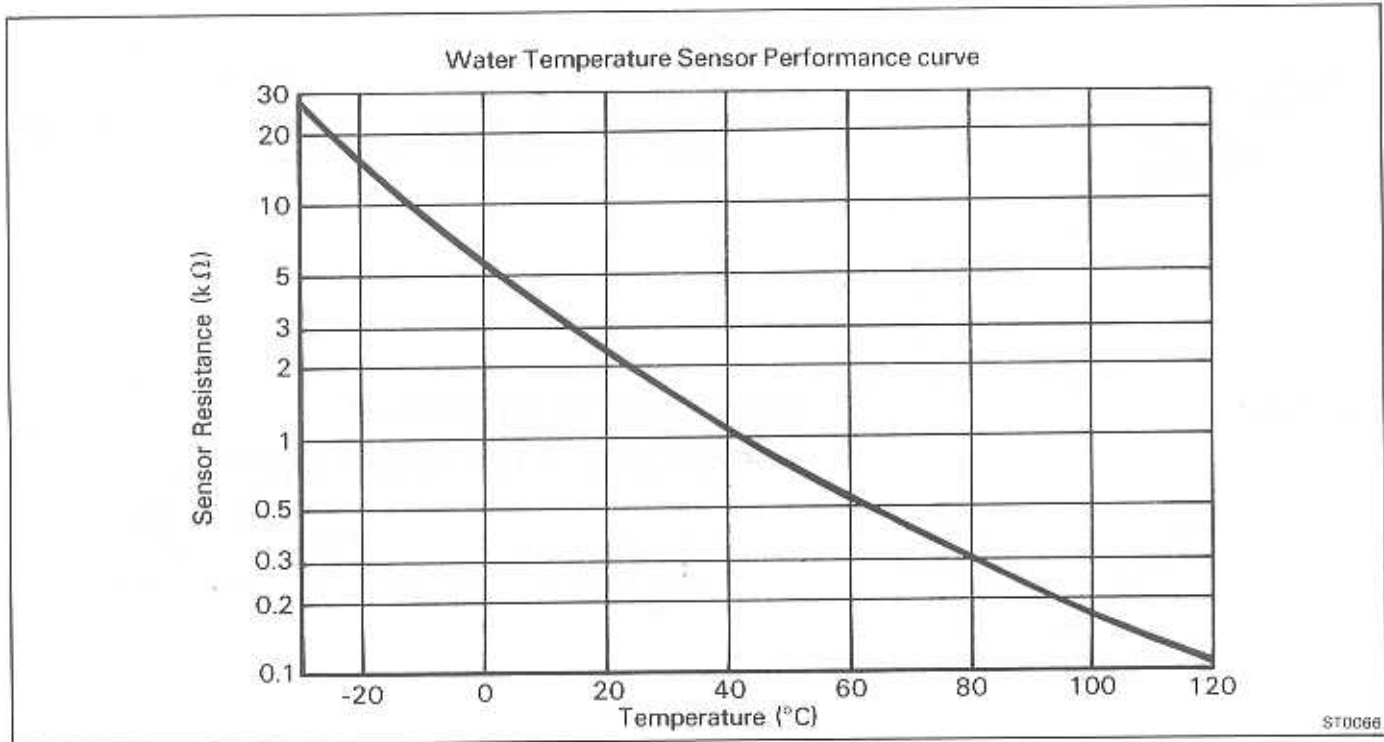

Main Relay
(See page CH-20)

Variable Delay Type [General Destinations (LH, LN, LX, LS)] SYSTEM CIRCUIT

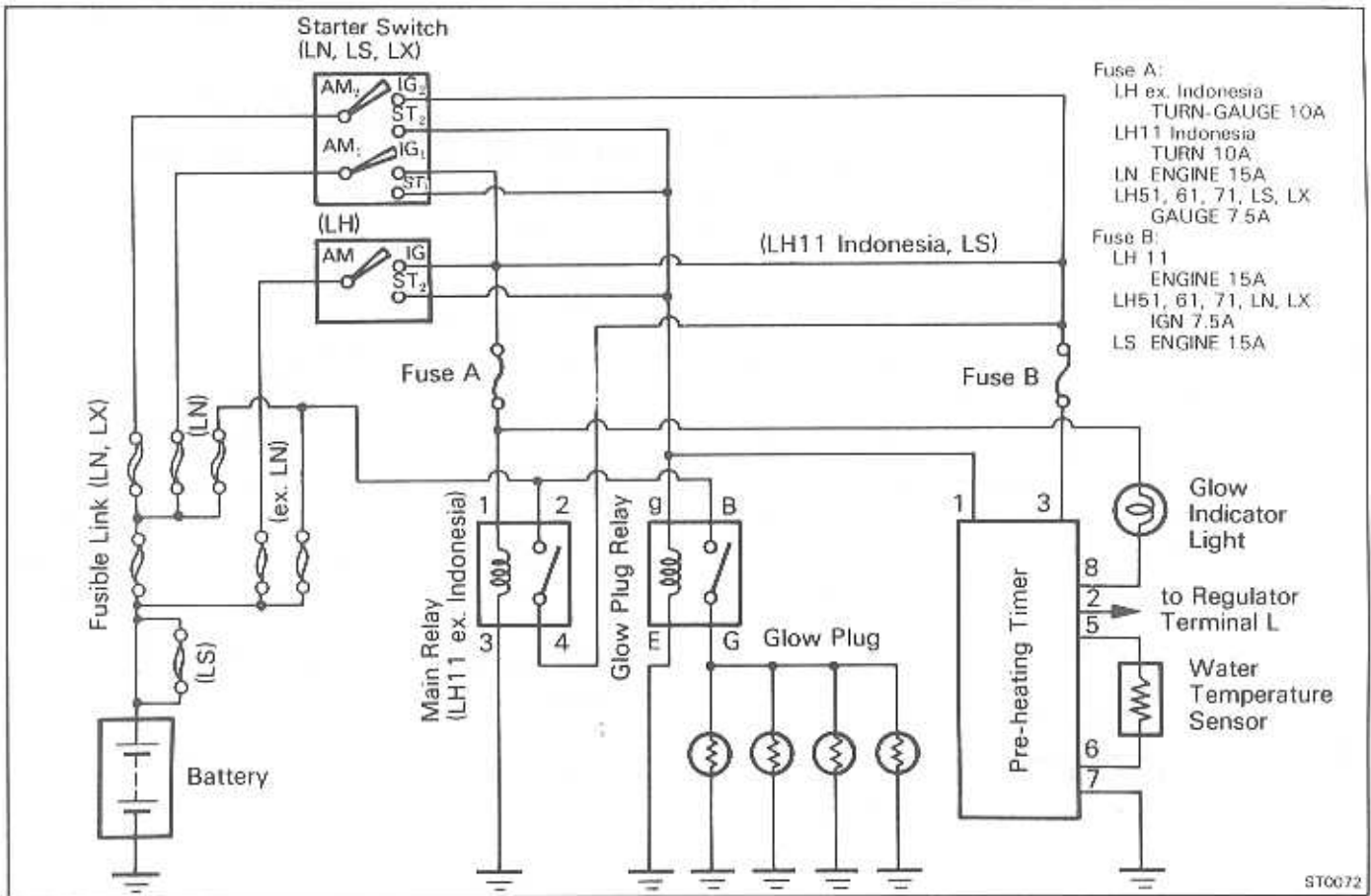

ST0072

LH11

Relationship Between Water Temperature and Timer Duration

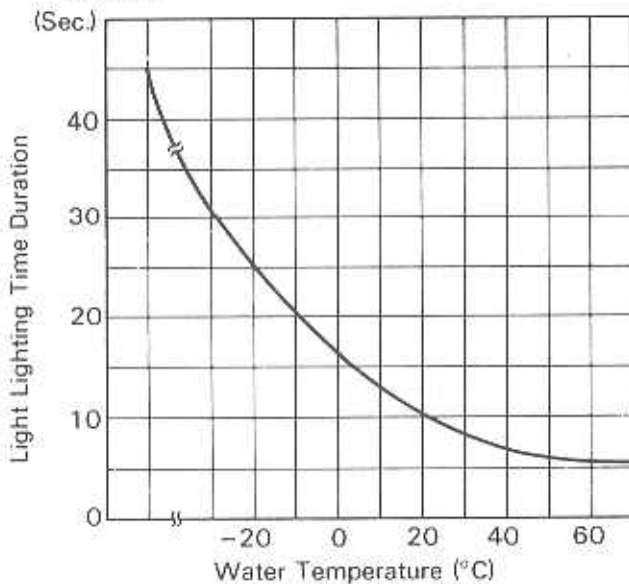

LH51, 61, 71, LN, LS, LX

Relationship Between Water Temperature and Timer Duration

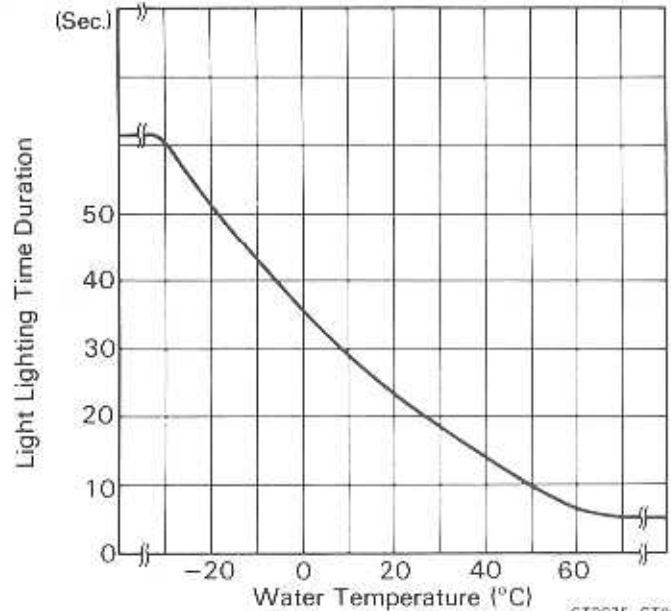

ST0075 ST0074

INSPECTION OF COMPONENTS

Pre-Heating Timer

LOCATION

LH11, LS, LX: Under the instrument panel on the passenger side.

LH51, 61, 71: Under the instrument panel center.

LN: In the left cowl.

(a) Turn the starter switch "ON" and measure the lighting time of the glow indicator light.

Glow time at 20°C (68°F): 9 – 15 seconds

LH 11

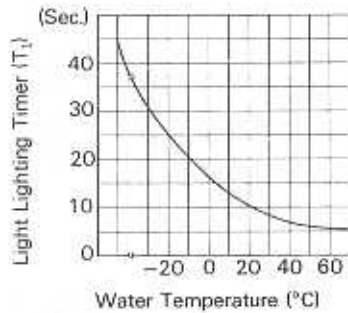

ST0075

LH51, 61, 71, LN, LS, LX

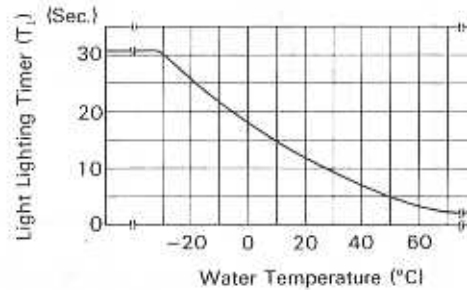

ST0162

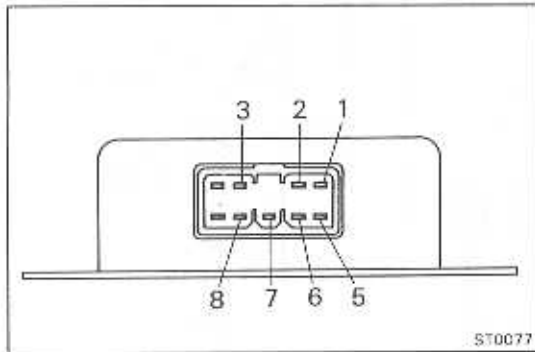

ST0077

- (b) Check that there is voltage at terminal 1 of the pre-heating timer when the starter switch is turned to "ON".
- (c) Turn the starter switch to "START", and then check that there is no voltage at terminal 1.

Glow Plug Relay

LOCATION

LH11: Under the instrument panel on the passenger side.

LH51, 61, 71: Under the instrument panel center.

LN, LS, LX: On the left fender apron in the engine compartment.

LH11, LN, LS, LX

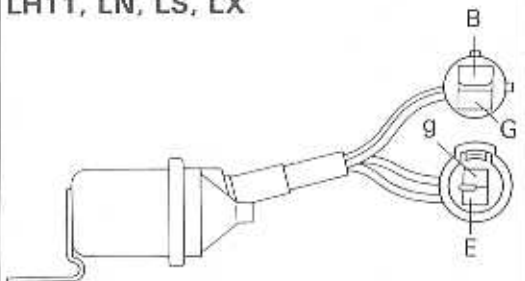

ST0062

INSPECT GLOW PLUG RELAY

(a) Using an ohmmeter, check for continuity between the following terminals:

- E ↔ g Continuity
- B ↔ G No continuity

(b) Apply battery voltage between terminals E and g.

- B ↔ G Continuity

If continuity is not as specified, replace the relay.

LH51, 61, 71

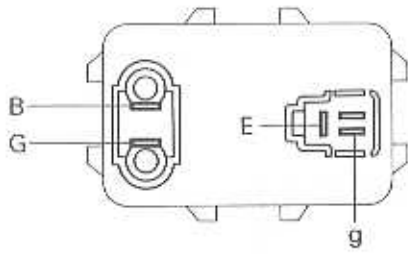

ST0070

Glow Plug

(See page ST-5)

Water Temperature Sensor

(See page ST-6)

Main Relay

(See page CH-20)

Fixed Delay Type (LY) SYSTEM CIRCUIT

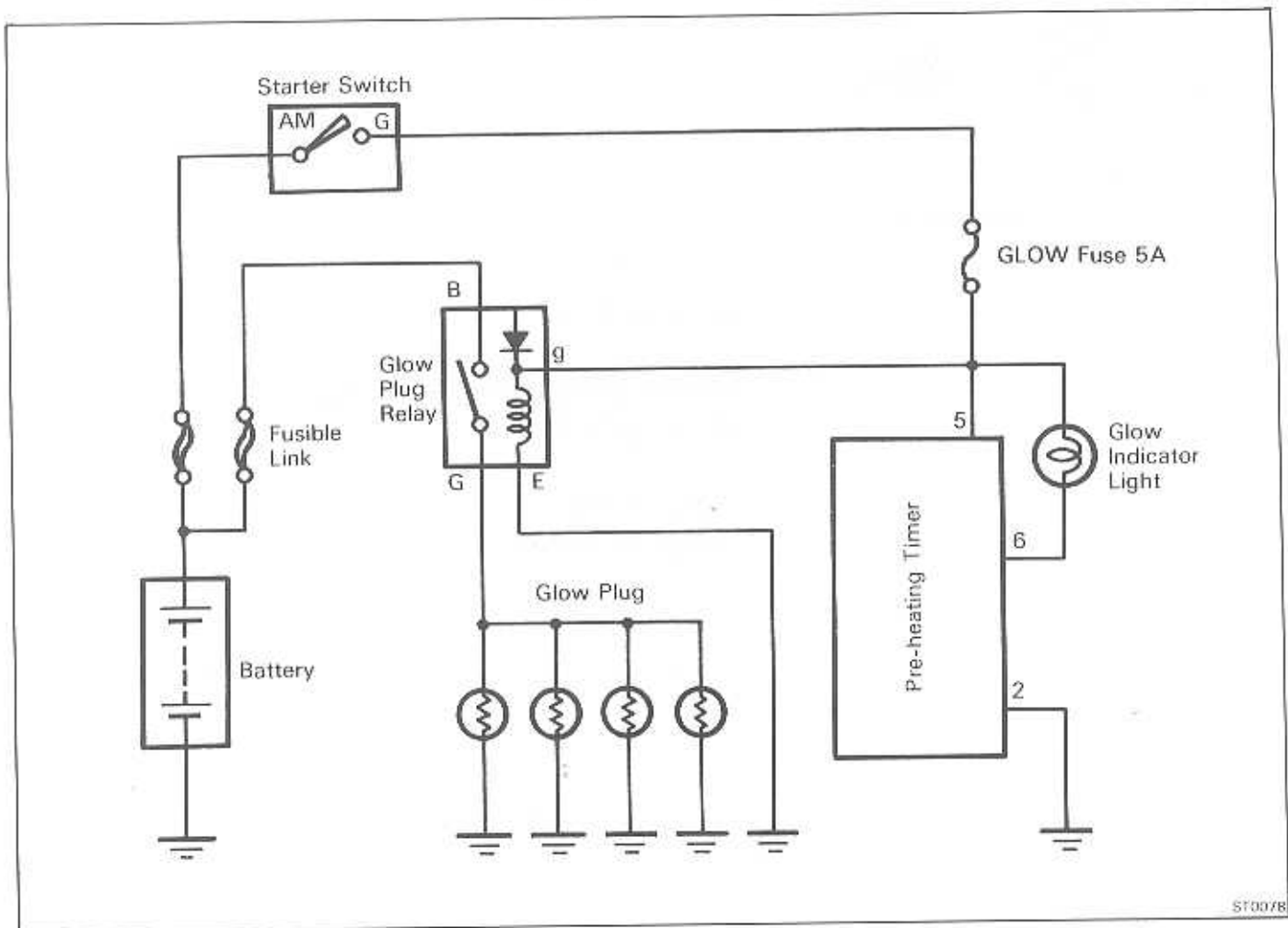

ST0078

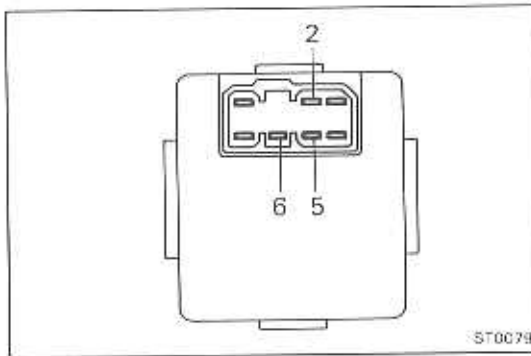

ST0079

INSPECTION OF COMPONENTS Pre-Heating Timer

LOCATION: Under the instrument panel on the passenger side.

INSPECT PRE-HEATING TIMER

- (a) Turn the starter switch to "G" and measure the lighting time of the glow indicator light.

**Glow time at $-25 - 60^{\circ}\text{C}$ ($-13 - 140^{\circ}\text{F}$):
15 - 19.5 seconds**

- (b) Check that there is voltage at terminal 5 of the pre-heating timer when the starter switch is turned to "G".

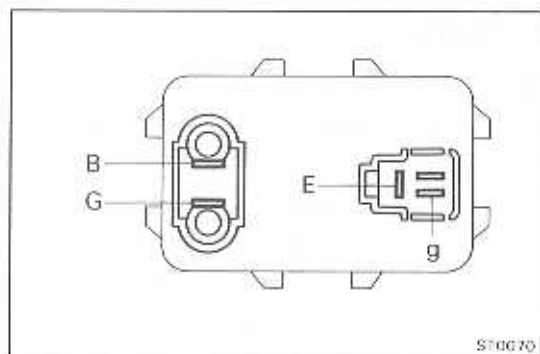

Glow Plug Relay

LOCATION: On the windshield wiper motor bracket.

INSPECT GLOW PLUG RELAY

- (a) Using an ohmmeter, check for continuity between the following terminals:
 - E ↔ g **Continuity**
 - B ↔ G **No continuity**
- (b) Apply battery voltage between terminals E and g.
 - B ↔ G **Continuity**

Manual Type (LF) SYSTEM CIRCUIT

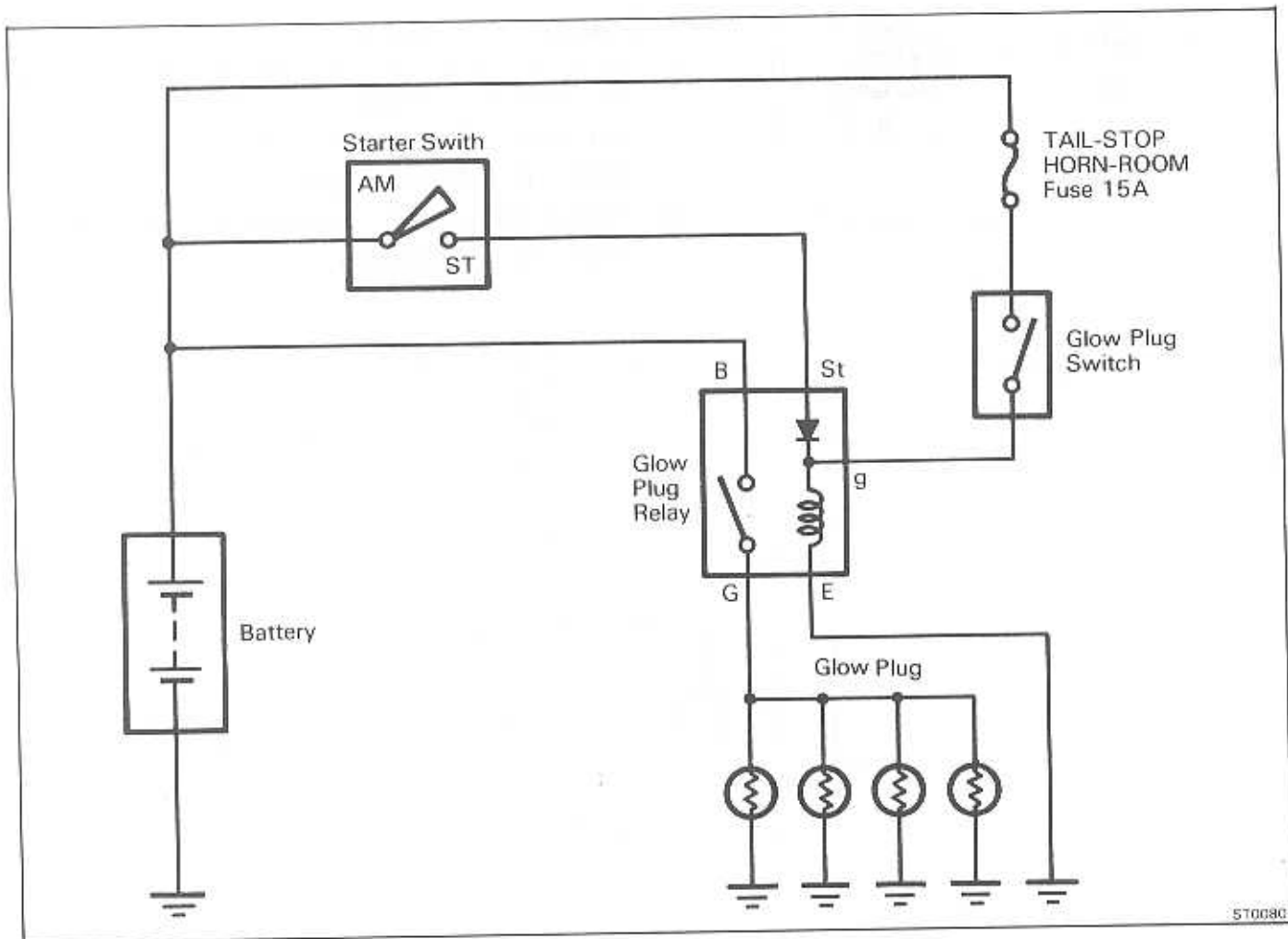

5T0080

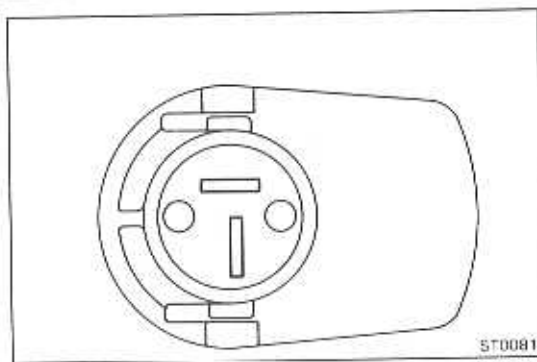

5T0081

INSPECTION OF COMPONENTS Glow Plug Switch

INSPECT GLOW PLUG SWITCH

Check for continuity between terminals.

Switch position	Terminal	
	B	g
OFF		
ON	○	○

If continuity is not as specified, replace the switch.

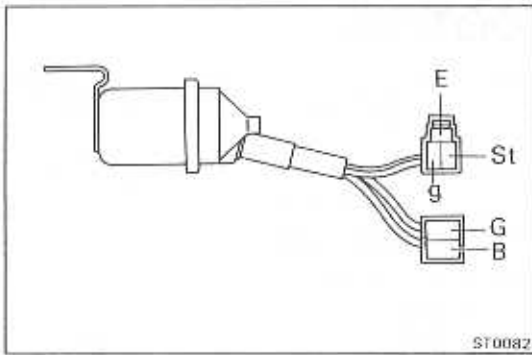

Glow Plug Relay

LOCATION: On the left fender apron in the engine compartment.

INSPECT GLOW PLUG RELAY

- (a) Using an ohmmeter, check for continuity between the following terminals.

• **E → g Continuity**

• **E → St**

Positive (+) test probe to terminal St

Negative (-) test probe to terminal E

Continuity

Positive (+) test probe to terminal E

Negative (-) test probe to terminal St

No continuity

• **B → G No continuity**

- (b) Apply battery voltage between terminals E and g.

• **B → G Continuity**

- (c) Apply battery voltage between terminals E and St.

• **B → G**

Battery positive (+) terminal to terminal St

Battery negative (-) terminal to terminal E

Continuity

If continuity is not as specified, replace the relay.

TROUBLESHOOTING

Problem	Possible cause	Remedy	Page
Engine will not crank	Battery charge low	Check battery specific gravity Charge or replace battery	CH-5
	Battery cables loose, corroded or worn	Repair or replace cables	ST-27 ST-15
	Fusible link blown	Replace fusible link	
	Starter relay faulty	Check relay	
	Starter faulty	Repair starter	
	Starter switch faulty	Replace starter switch	
Engine cranks slowly	Battery charge low	Check battery specific gravity Charge or replace battery	CH-5
	Battery cables loose, corroded or worn	Repair or replace cables	ST-15
	Starter faulty	Repair starter	
Starter continues to run	Starter faulty	Repair starter	ST-15
	Starter switch faulty	Replace starter switch	
	Short in wiring	Repair wiring	
Starter spins - engine will not crank	Pinion gear teeth broken or faulty starter	Repair starter	ST-15
	Flywheel teeth broken	Replace flywheel	

STARTING SYSTEM CIRCUIT

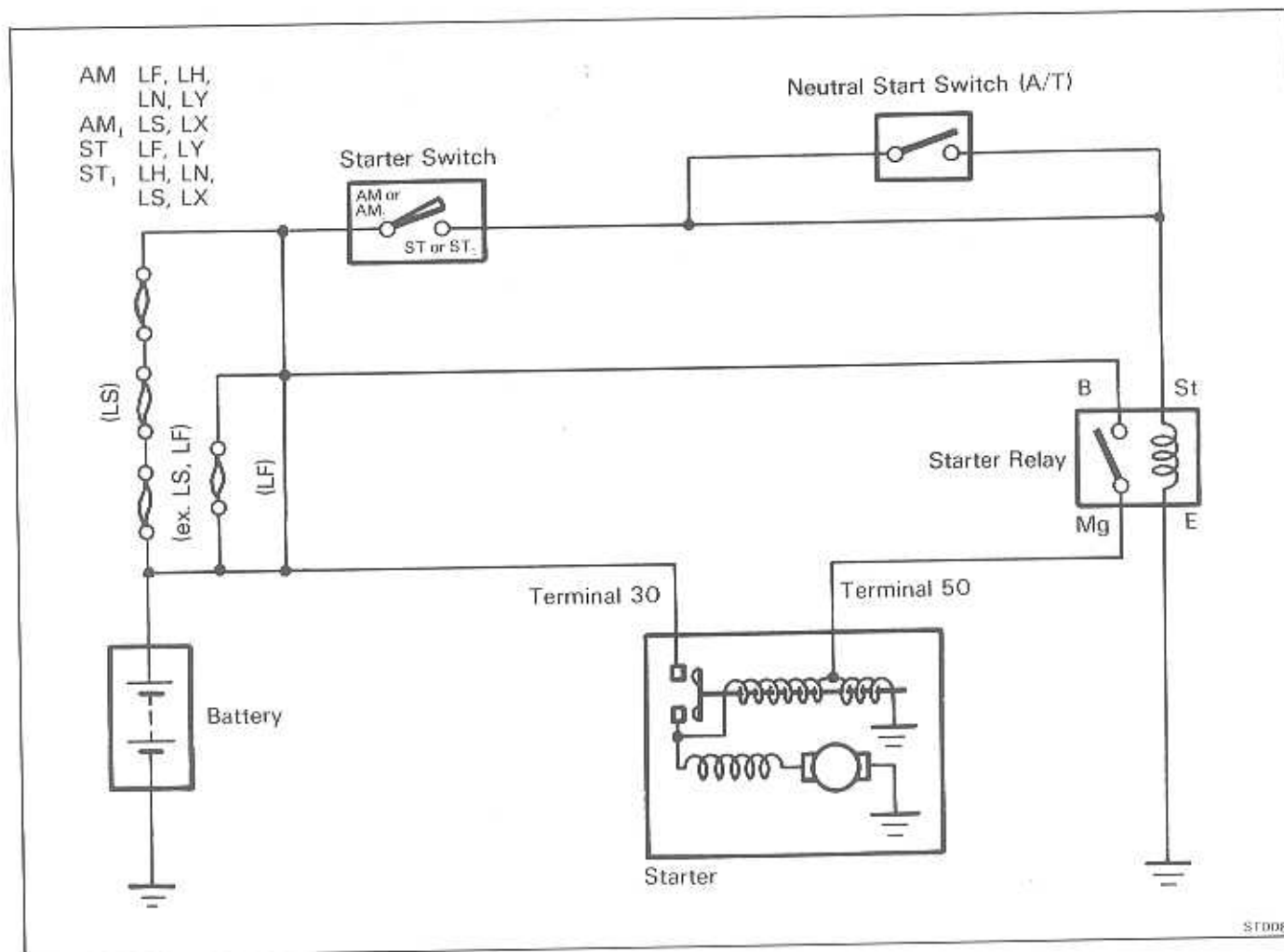

STARTER COMPONENTS

[2.0 kW Type]

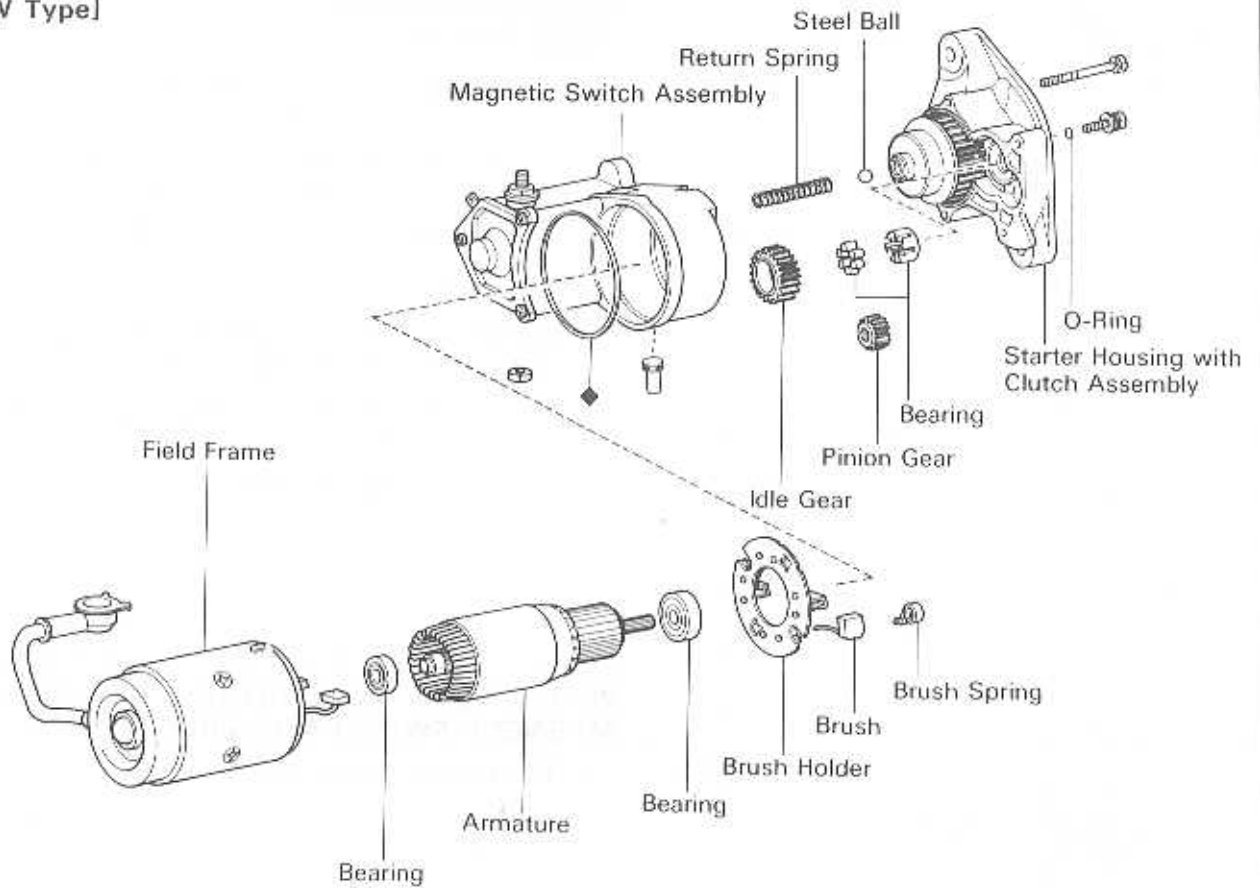

[2.5 kW Type]

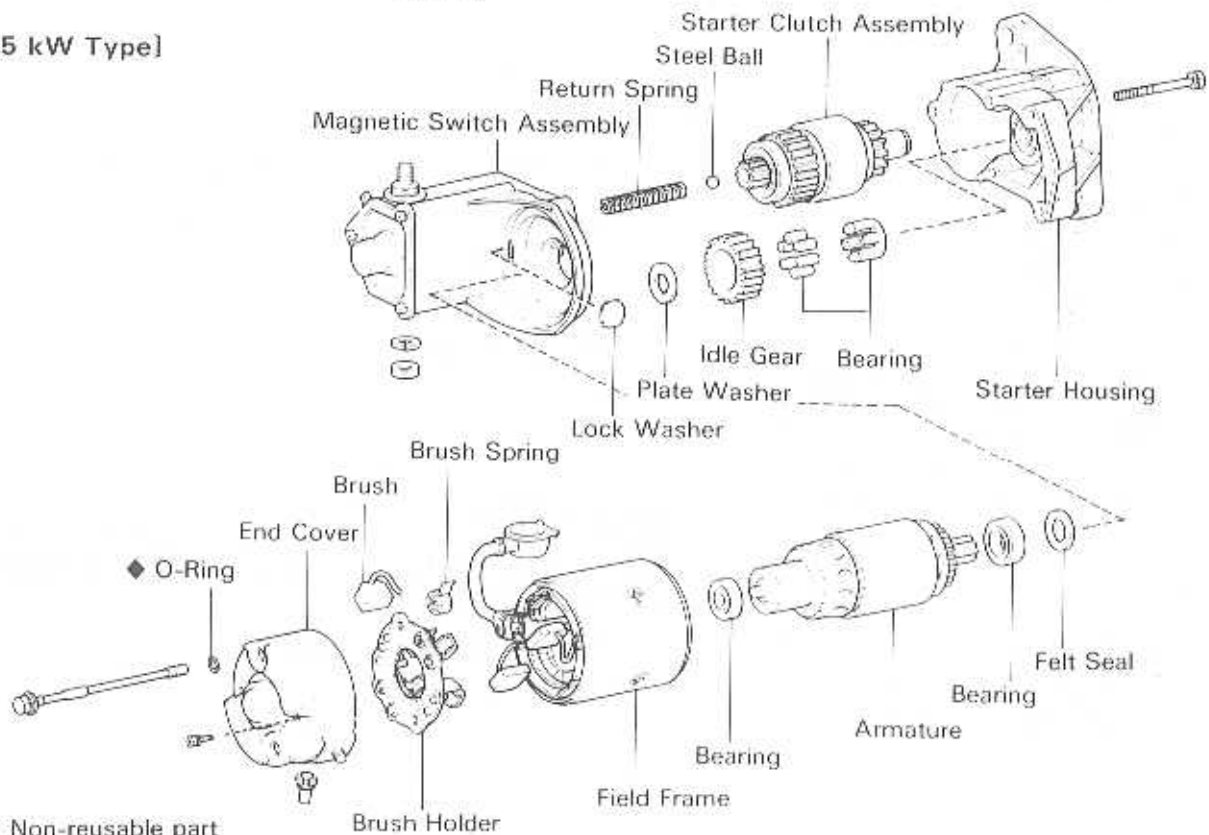

◆ : Non-reusable part

DISASSEMBLY OF STARTER

(See page ST-15)

**1. REMOVE FIELD FRAME WITH ARMATURE FROM MAGNETIC SWITCH
[2.0 kW TYPE]**

- (a) Remove the nut. Disconnect the lead wire from the magnetic switch terminal.
- (b) Remove the two bolts, plate washers and O-rings. Pull out the field frame with the armature.
- (c) Remove the O-ring from the field frame.

[2.5 kW TYPE]

- (a) Remove the nut and spring washer. Disconnect the lead wire from the magnetic switch terminal.
- (b) Remove the two through bolts, plate washers and O-rings. Pull out the field frame with the armature.
- (c) Remove the felt seal and lock plate.

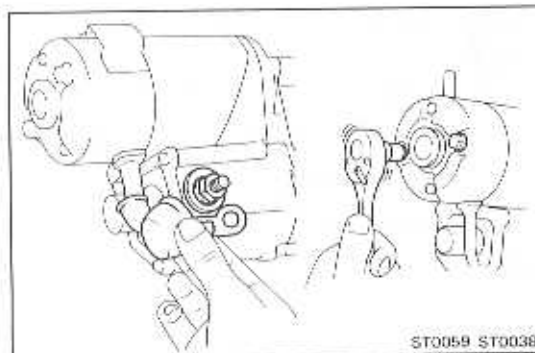
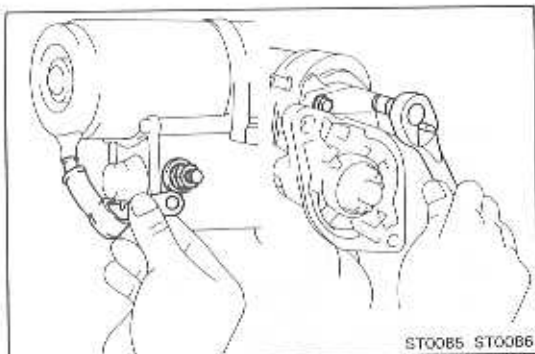
**2. [2.0 kW TYPE]
REMOVE STARTER HOUSING, IDLE GEAR AND PINION GEAR WITH CLUTCH ASSEMBLY FROM MAGNETIC SWITCH ASSEMBLY**

- (a) Remove the two screws.
- (b) Remove the following parts:
 - (1) Starter housing with clutch assembly
 - (2) Return spring
 - (3) Idle gear
 - (4) Bearing
 - (5) Pinion gear

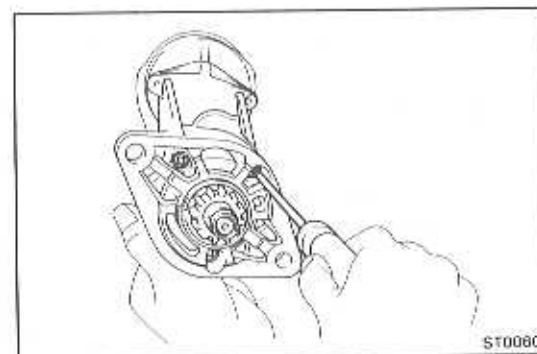
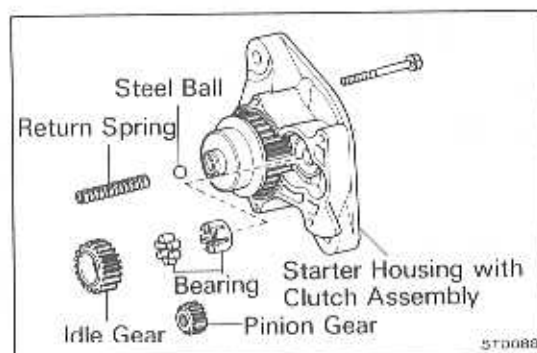
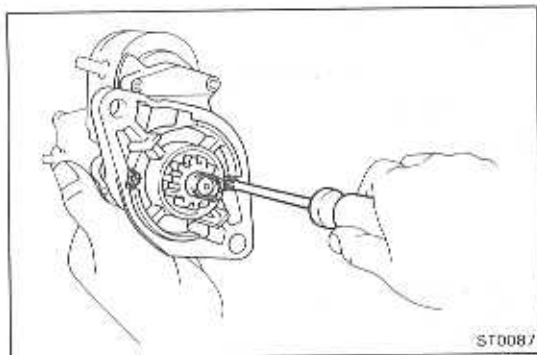
**[2.5 kW TYPE]****REMOVE STARTER HOUSING, STARTER CLUTCH ASSEMBLY AND IDLE GEAR FROM MAGNETIC SWITCH ASSEMBLY**

- (a) Remove the three screws.

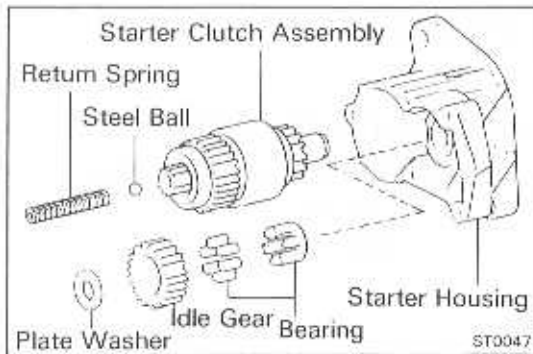

- (b) Remove the following parts:
- (1) Starter housing
 - (2) Clutch assembly
 - (3) Return spring
 - (4) Plate washer
 - (5) Idle gear
 - (6) Bearing

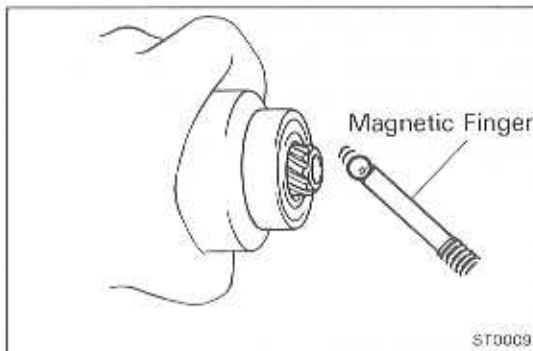

3. REMOVE STEEL BALL

Using a magnetic finger, remove the steel ball from the clutch shaft hole.

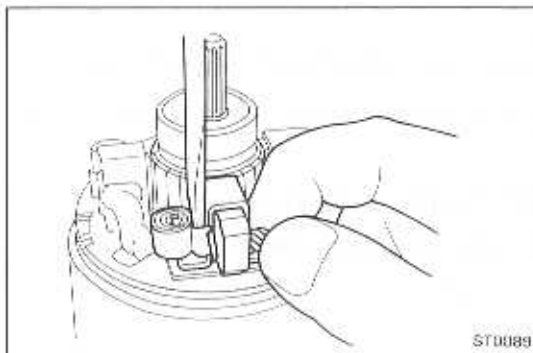

4. REMOVE BRUSHES AND BRUSH HOLDER [2.0 kW TYPE]

- (a) Using a screwdriver, hold the brush spring back, and remove the brush from the brush holder. Remove the four brushes.
- (b) Pull the brush holder off the field frame.

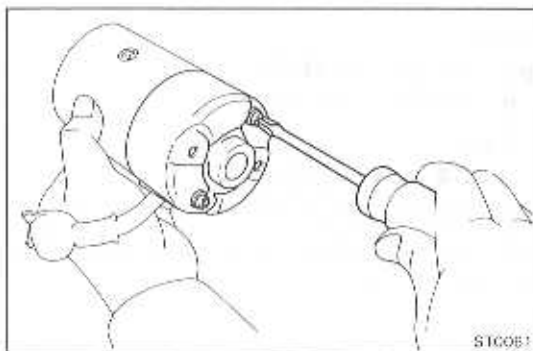

[2.5 kW TYPE]

- (a) Remove the two screws and end cover.

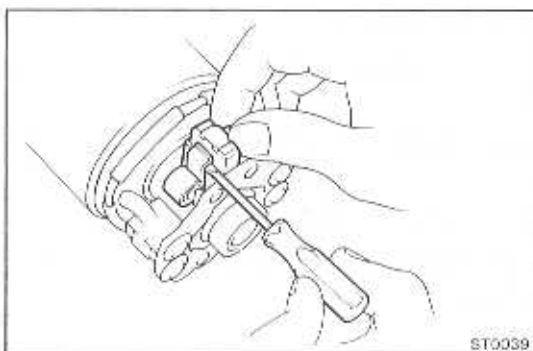

- (b) Using a screwdriver, hold the brush spring back, and remove the brush from the brush holder. Remove the four brushes.

- (c) Pull the brush holder off the field frame.

5. REMOVE ARMATURE FROM FIELD FRAME

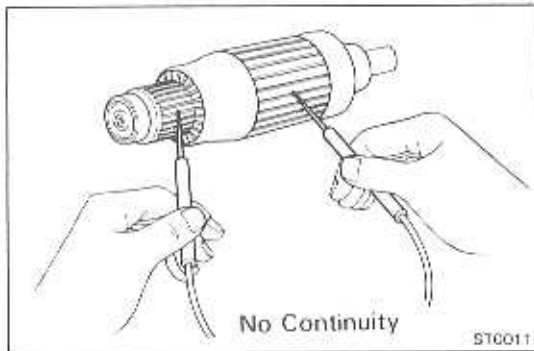
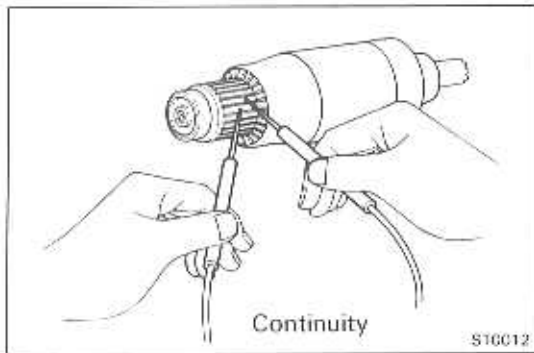

INSPECTION OF STARTER

Armature Coil

1. INSPECT COMMUTATOR FOR OPEN CIRCUIT

Using an ohmmeter, check that there is continuity between the segments of the commutator.

If there is no continuity, replace the armature.

2. INSPECT COMMUTATOR FOR GROUND

Using an ohmmeter, check that there is no continuity between the commutator and armature coil core.

If there is continuity, replace the armature.

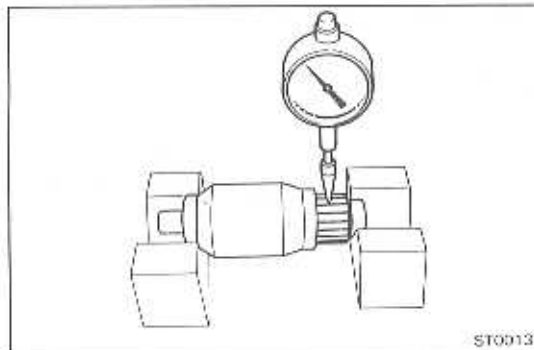

Commutator

1. INSPECT COMMUTATOR FOR DIRT AND BURNS

If the surface is dirty or burnt, correct with sandpaper (No. 400) or a lathe.

2. INSPECT COMMUTATOR CIRCLE RUNOUT

Maximum circle runout: 0.05 mm (0.0020 in.)

If the circle runout is greater than maximum, correct with a lathe.

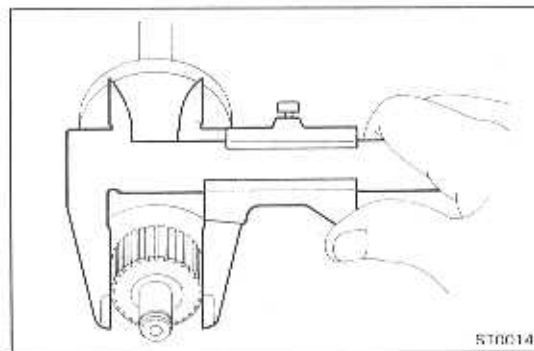

3. INSPECT DIAMETER OF COMMUTATOR

Standard diameter:

2.0 kW type 35 mm (1.38 in.)

2.5 kW type 36 mm (1.42 in.)

Minimum diameter:

2.0 kW type 34 mm (1.34 in.)

2.5 kW type 35 mm (1.38 in.)

If the diameter of the commutator is less than minimum, replace the armature.

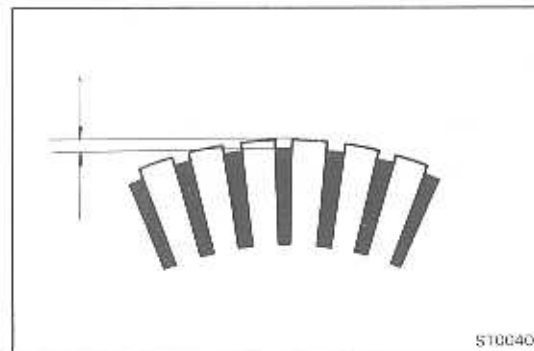

4. INSPECT UNDERCUT DEPTH

Check that the undercut depth is clean and free of foreign particles. Smoothen out the edge.

Standard undercut depth: 0.7 – 0.9 mm
(0.028 – 0.035 in.)

Minimum undercut depth: 0.2 mm (0.008 in.)

If the undercut depth is less than the minimum, correct it with a hacksaw blade.

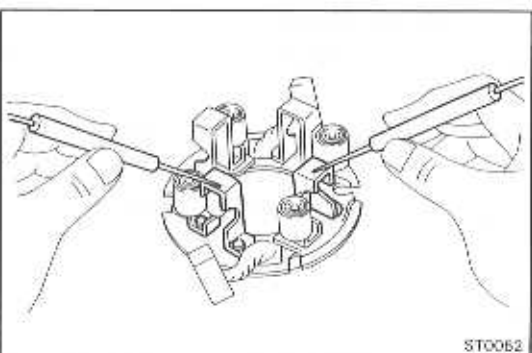
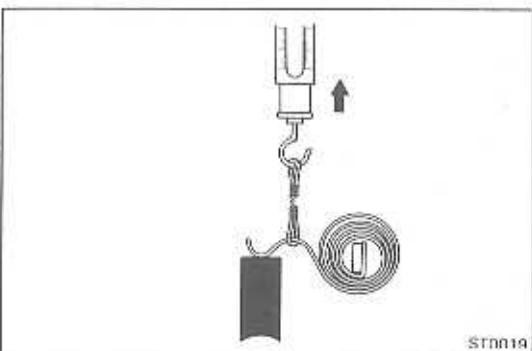
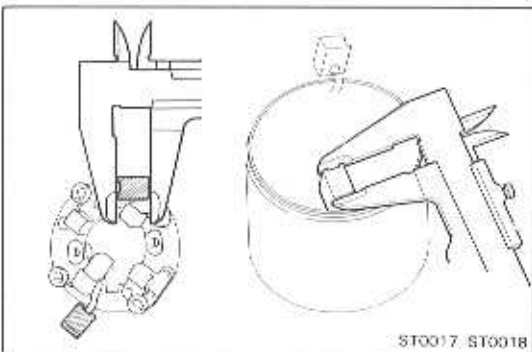
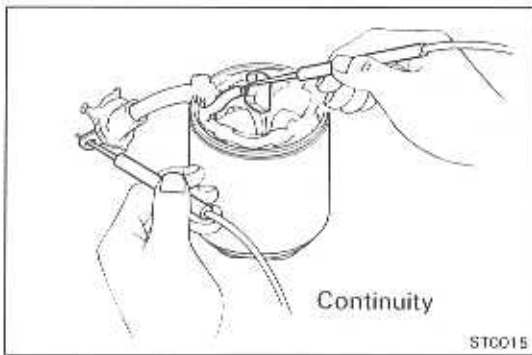

Field Coil

1. INSPECT FIELD COIL FOR OPEN CIRCUIT

Using an ohmmeter, check that there is continuity between the lead wire and field coil brush lead.

If there is no continuity, replace the field coil.

2. INSPECT FIELD COIL FOR GROUND

Using an ohmmeter, check that there is no continuity between the lead wire and field frame.

If there is continuity, repair or replace the field coil.

Brushes

INSPECT BRUSH LENGTH

Standard length:

2.0 kW type 15.0 – 15.5 mm (0.591 – 0.610 in.)

2.5 kW type 20.5 – 21.0 mm (0.807 – 0.827 in.)

Minimum length:

2.0 kW type 9.5 mm (0.374 in.)

2.5 kW type 13.0 mm (0.512 in.)

If the length is less than minimum, replace the field frame and/or brush holder.

Brush Springs

INSPECT BRUSH SPRING LOAD

NOTE: Take the pull scale reading at the very instant the brush spring separates from the brush.

Spring installed load:

2.0 kW type 2.7 – 3.3 kg
(6.0 – 7.3 lb, 26 – 32 N)

2.5 kW type 3.2 – 4.0 kg
(7.1 – 8.8 lb, 31 – 39 N)

Brush Holder

INSPECT INSULATION OF BRUSH HOLDER

Using an ohmmeter, check that there is no continuity between the positive and negative brush holders.

If there is continuity, repair or replace the brush holder.



ST0020

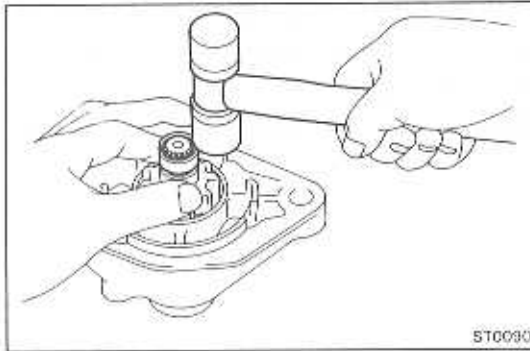

ST0030

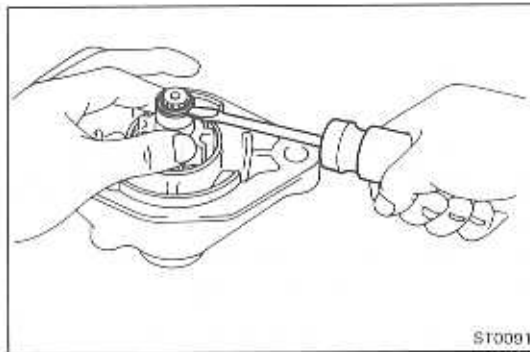

ST0091

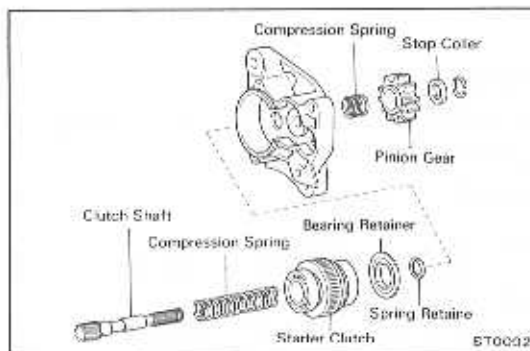

ST0042

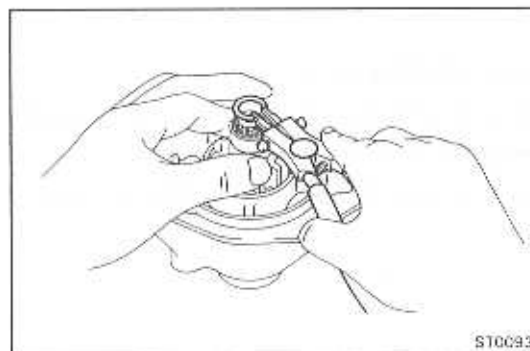

ST0093

Clutch and Gears

1. INSPECT GEAR TEETH

Check the gear teeth on the pinion gear, idler gear and clutch assembly for wear or damage. Replace if damaged. If damaged, also check the flywheel ring gear for wear or damage.

2. INSPECT CLUTCH

Rotate the pinion gear clockwise and check that it turns freely. Try to rotate the pinion gear counterclockwise and check that it locks.

If necessary, replace the clutch assembly.

3. [2.0 kW TYPE] IF NECESSARY, REPLACE CLUTCH ASSEMBLY

(a) Push down the pinion gear and, using a plastic hammer, tap in the stop collar.

(b) Using a screwdriver, pry out the snap ring.

(c) Remove the following parts from the starter housing:

- (1) Stop collar
- (2) Pinion gear
- (3) Compression spring
- (4) Spring retainer
- (5) Bearing retainer
- (6) Starter clutch
- (7) Compression spring
- (8) Clutch shaft

(d) Assemble the clutch shaft, compression spring, starter clutch, bearing retainer and spring retainer, and install them to the starter housing.

(e) Install the compression spring, pinion gear and stop collar.

(f) Push down the pinion gear and, using snap ring pliers, install the snap ring.

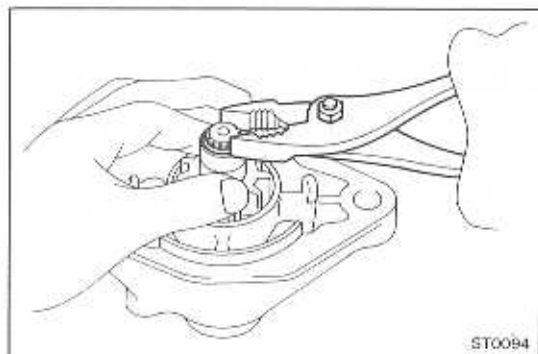

ST0094

- (g) Using pliers, compress the snap ring. Make sure that the snap ring fits correctly.

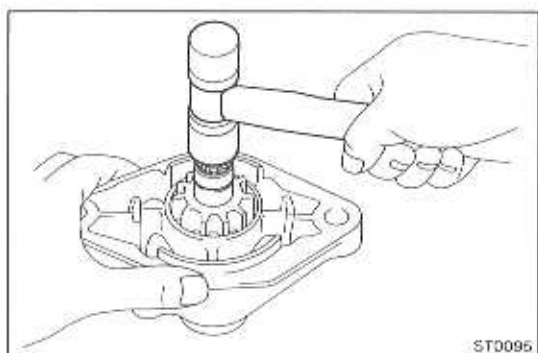

ST0095

- (h) Using a plastic hammer, tap the clutch shaft and install the stop collar onto the snap ring.

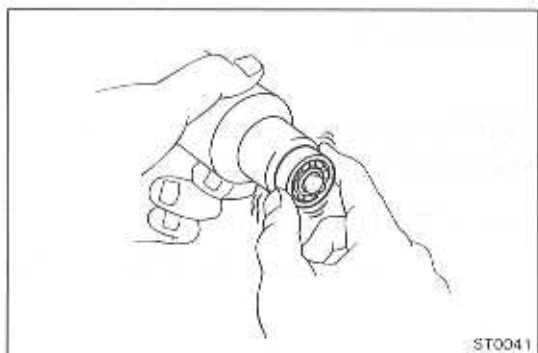

ST0341

Bearings

1. INSPECT BEARINGS

Turn each bearing by hand while pushing inward.

If resistance is felt or if the bearing sticks, replace the bearing.

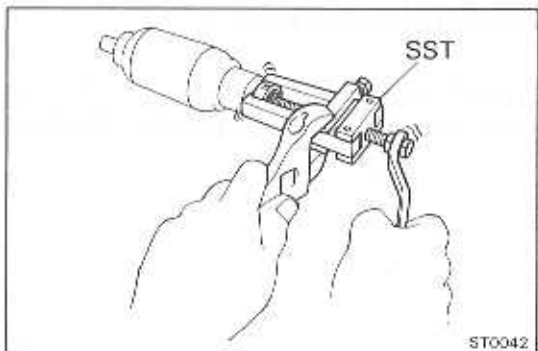

ST0042

2. IF NECESSARY, REPLACE BEARINGS

- (a) Using SST, remove the bearing from the armature shaft.

- (b) Using SST, remove the other bearing from the opposite side.

SST 09286-46011

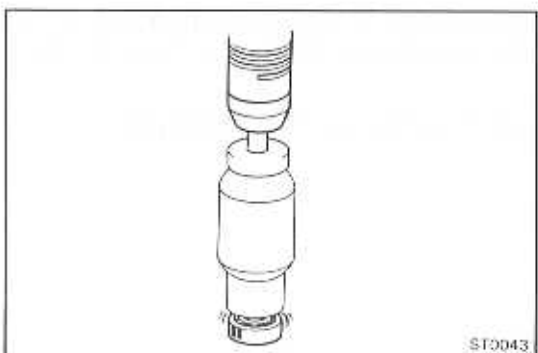

ST0043

- (c) Using a press, install the bearings onto the shaft.

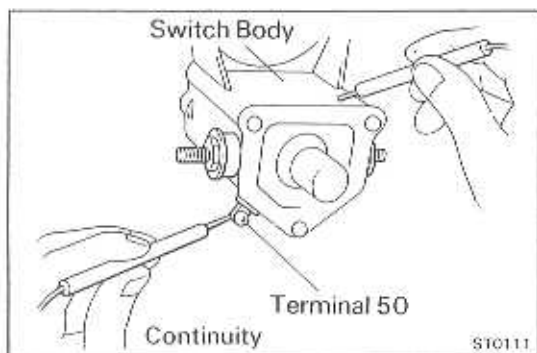
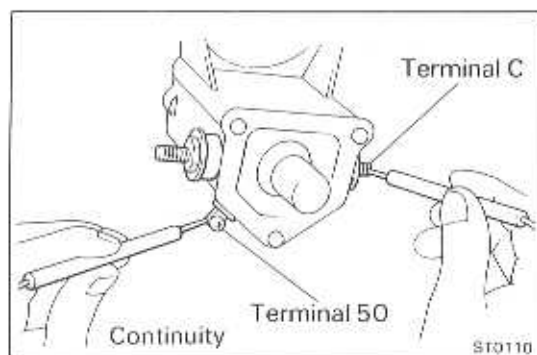

Magnetic Switch

1. PERFORM PULL-IN COIL OPEN CIRCUIT TEST

Using an ohmmeter, check that there is continuity between terminals 50 and C.

If there is no continuity, replace the magnetic switch.

2. PERFORM HOLD-IN COIL OPEN CIRCUIT TEST

Using an ohmmeter, check that there is continuity between terminal 50 and the switch body.

If there is no continuity, replace the magnetic switch.

ASSEMBLY OF STARTER

(See page ST-15)

NOTE: Use No. 50 Denso grease to lubricate the bearings and gears when assembling the starter.

1. PLACE ARMATURE INTO FIELD FRAME

Apply grease to the armature bearings and insert the armature into the field frame.

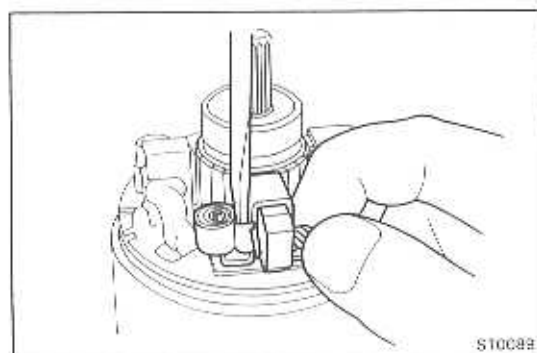
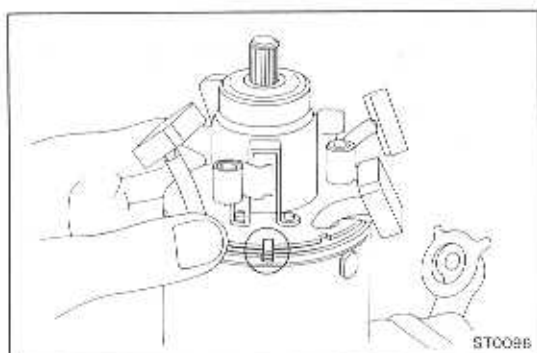

2. INSTALL BRUSH HOLDER AND BRUSHES [2.0 kW TYPE]

(a) Place the brush holder on the armature shaft and align the tab of the holder with the notch of the field frame.

(b) Using a screwdriver, hold the brush spring back, and install the brush into the brush holder. Install the four brushes.

NOTE: Make sure that the positive lead wires are not grounded.

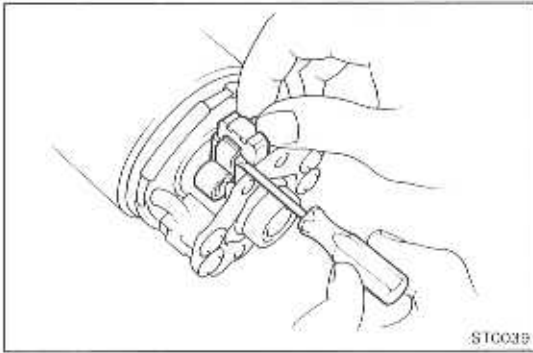
**[2.5 kW TYPE]**

- (a) Place the brush holder on the armature shaft.
- (b) Using a screwdriver, hold the brush spring back and install the brush into the brush holder. Install the four brushes.

NOTE: Check that the positive lead wires are not grounded.

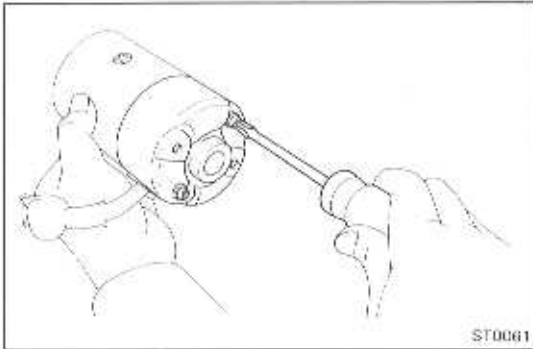

- (c) Install the end cover with the two screws.

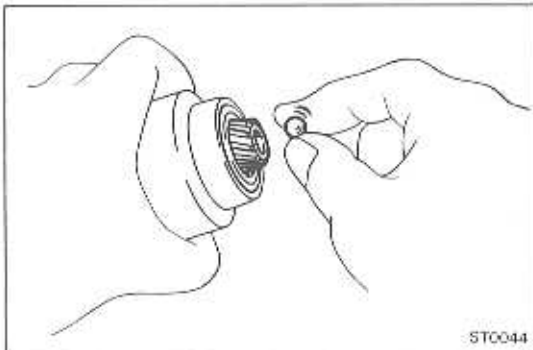
**3. INSERT STEEL BALL INTO CLUTCH SHAFT HOLE**

Apply grease to the ball, and insert it into the clutch shaft hole.

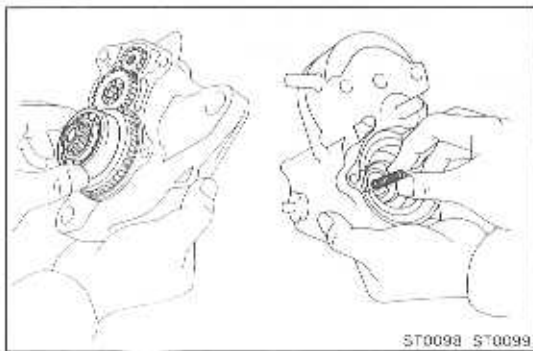

**4. [2.0 kW TYPE]
INSTALL IDLE GEAR, BEARING, PINION GEAR AND
RETURN SPRING TO STARTER HOUSING AND
MAGNETIC SWITCH ASSEMBLY**

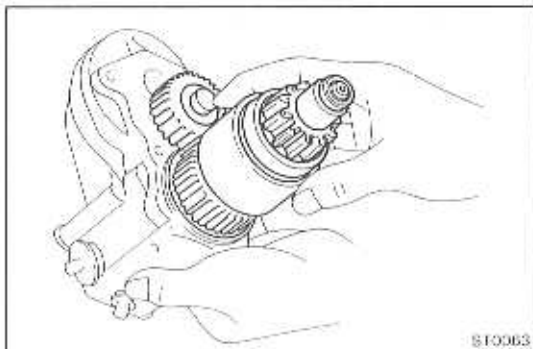

**[2.5 kW TYPE]
INSTALL RETURN SPRING, STARTER HOUSING,
PLATE WASHER, IDLE GEAR AND BEARING TO
MAGNETIC SWITCH ASSEMBLY**

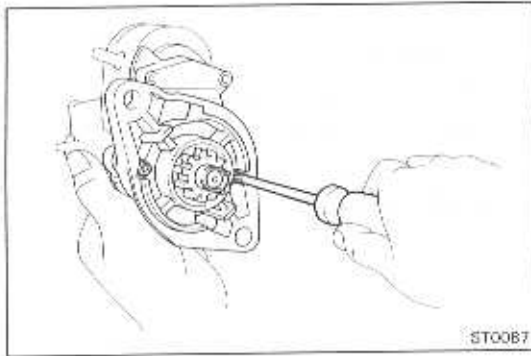

**5. INSTALL STARTER HOUSING
[2.0 kW TYPE]**

Install the starter housing to the magnetic switch assembly with the two screws.

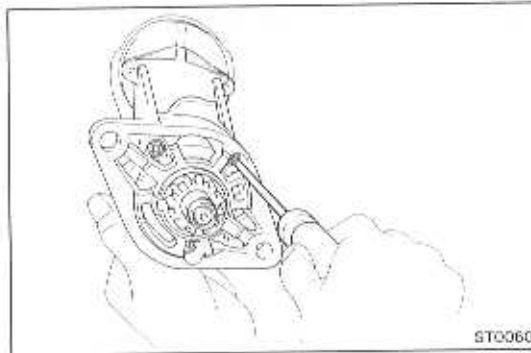

[2.5 kW TYPE]

Install the starter housing to the magnetic switch assembly with the three screws.

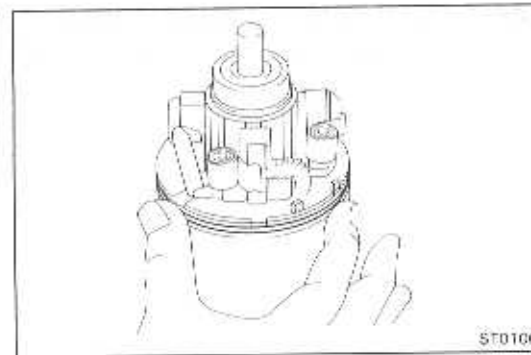

**6. INSTALL FIELD FRAME WITH ARMATURE IN
MAGNETIC SWITCH
[2.0 kW TYPE]**

(a) Place the O-ring on the field frame.

(b) Align the bolt anchor of the field frame with the mark on the magnetic switch assembly and insert the field frame with the armature.

(c) Install the two bolts with the plate washers and O-rings.

(d) Connect the lead wire to the magnetic switch terminal.

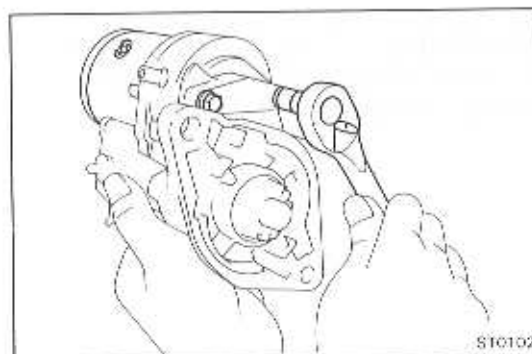
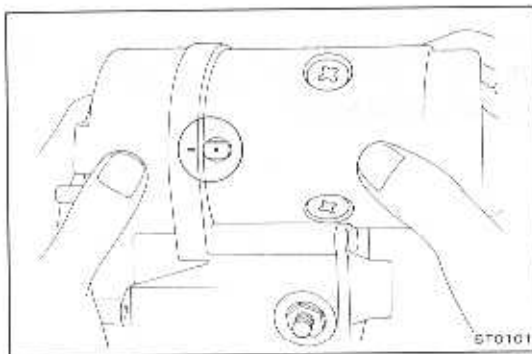

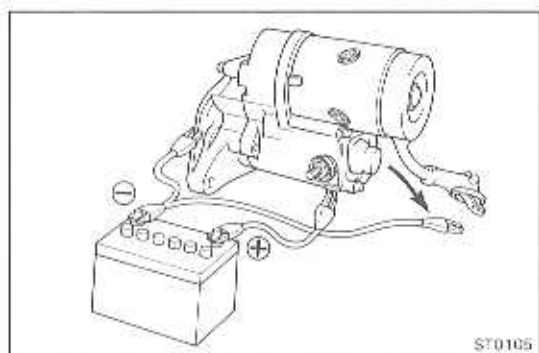
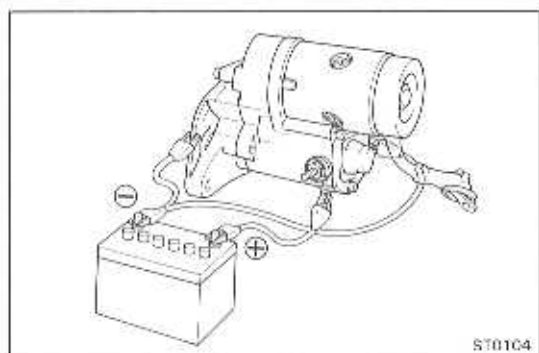
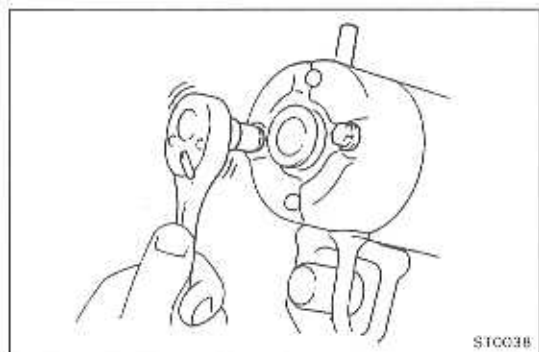
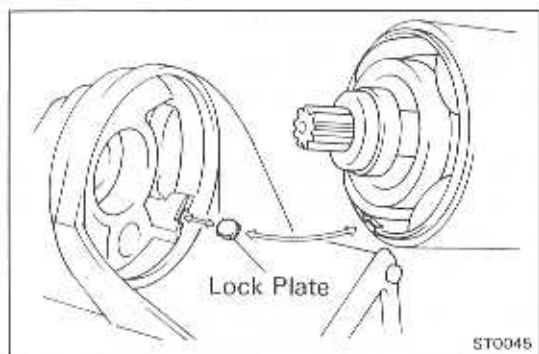
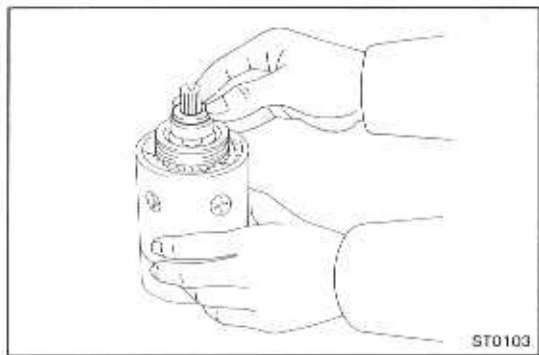
**[2.5 kW TYPE]**

(a) Place the felt seal on the armature shaft.

(b) Place the lock plate on the magnetic switch.

(c) Align the lock plate with the notch on the field frame and insert the field frame with the armature.

(d) Install the two through bolts with the plate washers and O-rings.

(e) Connect the lead wire to the magnetic switch terminal.

PERFORMANCE TEST OF STARTER

CAUTION: These tests must be performed within 3 to 5 seconds to avoid burning out the coil.

1. PERFORM PULL-IN TEST

(a) Disconnect the lead wire from terminal C.

(b) Connect the battery to the magnetic switch as shown. Check that the plunger moves outward.

If the plunger does not move, replace the magnetic switch.

2. PERFORM HOLD-IN TEST

While connected as above with the plunger out, disconnect the negative lead from terminal C. Check that the plunger remains out.

If the plunger returns inward, replace the magnetic switch.

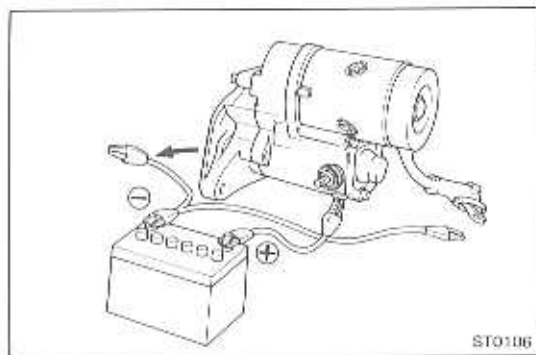

ST0106

3. INSPECT PLUNGER RETURN

Disconnect the negative lead from the switch body. Check that the plunger returns inward.

If the plunger does not return, replace the magnetic switch.

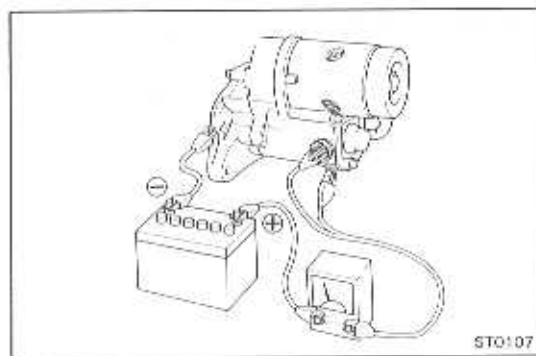

ST0107

4. PERFORM NO-LOAD PERFORMANCE TEST

- (a) Connect the lead wire to terminal C.
- (b) Connect the battery and an ammeter to the starter as shown.
- (c) Check that the starter rotates smoothly and steadily with the pinion moving out. Check that the ammeter reads the specified current.

Specified current:

2.0 kW type less than 120 A at 11.5 V
 2.5 kW type less than 180 A at 11.0 V

STARTER RELAY

LOCATION

LH 11: Under the instrument panel on the passenger side.

LF, LN, LS, LX: On the left fender apron in the engine compartment.

LH 51, 61, 71: Under the combination meter

LY: Under the instrument panel on the passenger side.

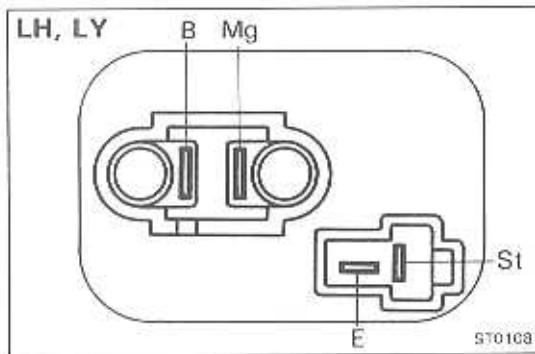

INSPECTION OF STARTER RELAY

INSPECT STARTER RELAY

(a) Using an ohmmeter, check for continuity between the following terminals:

- E ↔ St Continuity
- B ↔ Mg No continuity

(b) Apply battery voltage between terminals E and St.

- B ↔ Mg Continuity

If continuity is not as specified, replace the relay.

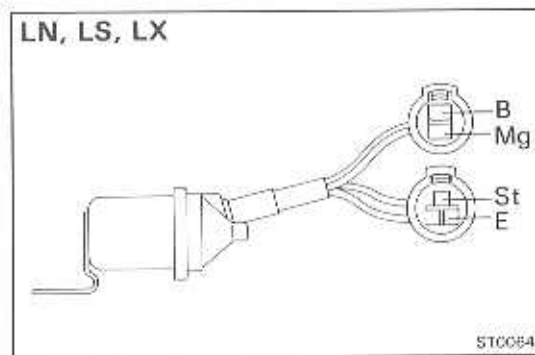
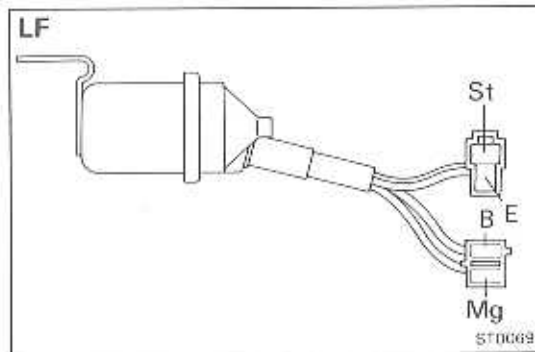

CHARGING SYSTEM

	Page
PRECAUTIONS	CH-2
TROUBLESHOOTING	CH-2
CHARGING SYSTEM CIRCUIT	CH-3
ON-VEHICLE INSPECTION	CH-5
ALTERNATOR	CH-8
ALTERNATOR REGULATOR	CH-18
CHARGE LIGHT RELAY	CH-20
MAIN RELAY	CH-20

PRECAUTIONS

1. Check that the battery cables are connected to the correct terminals.
2. Disconnect the battery cables when the battery is given a quick charge.
3. Do not perform tests with a high voltage insulation resistance tester.
4. Never disconnect the battery when the engine is running.

TROUBLESHOOTING

Problem	Possible cause	Remedy	Page
Charge light does not light with starter switch at "ON" and engine not running	Fuse blown	Check fuses ● Fuse A: LF WIPER-GAUGE LH11 (Indonesia) TURN LH11 (ex. Indonesia) TURN-GAUGE LH51, 61, 71, LN, LX IGN LY METER ● Fuse B: LH11 (Indonesia), LH51, 61, 71, LN, LS, LX, LY CHARGE ● Fuse C: ex. LF ENGINE LF IG-TURN	CH-3, 4
	Light burned out	Replace light	
	Wiring connection loose	Tighten loose connections	
	Alternator regulator faulty	Check regulator	CH-20
	Charge light relay faulty	Check relay	CH-18
	IC regulator faulty	Replace IC regulator	CH-9
Discharge warning light does not go out with engine running (battery requires frequent recharging)	Drive belt loose or worn	Adjust or replace drive belt	CH-5
	Battery cables loose, corroded or worn	Repair or replace cables	
	Fuse blown	Check fuse C: ex. LF ENGINE LF IG-TURN	CH-3
	Main relay faulty (w/o IC regulator)	Check main relay	CH-20
	Fusible link blown	Replace fusible link	
	Alternator regulator, charge light relay, IC regulator or alternator faulty	Check charging system	CH-5
	Wiring faulty	Repair wiring	

CHARGING SYSTEM CIRCUIT

w/o IC Regulator [LF, LH11 (Indonesia), LY]

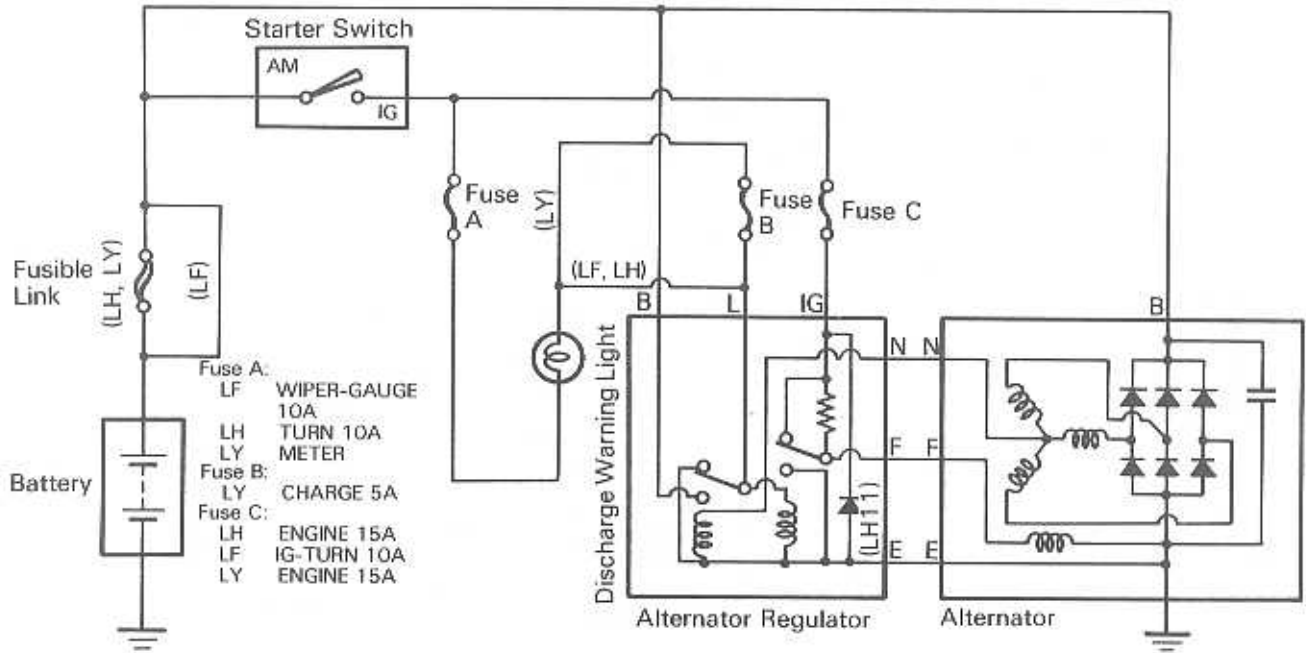

w/o IC Regulator [LH11 (ex. Indonesia), LH51, 61, 71]

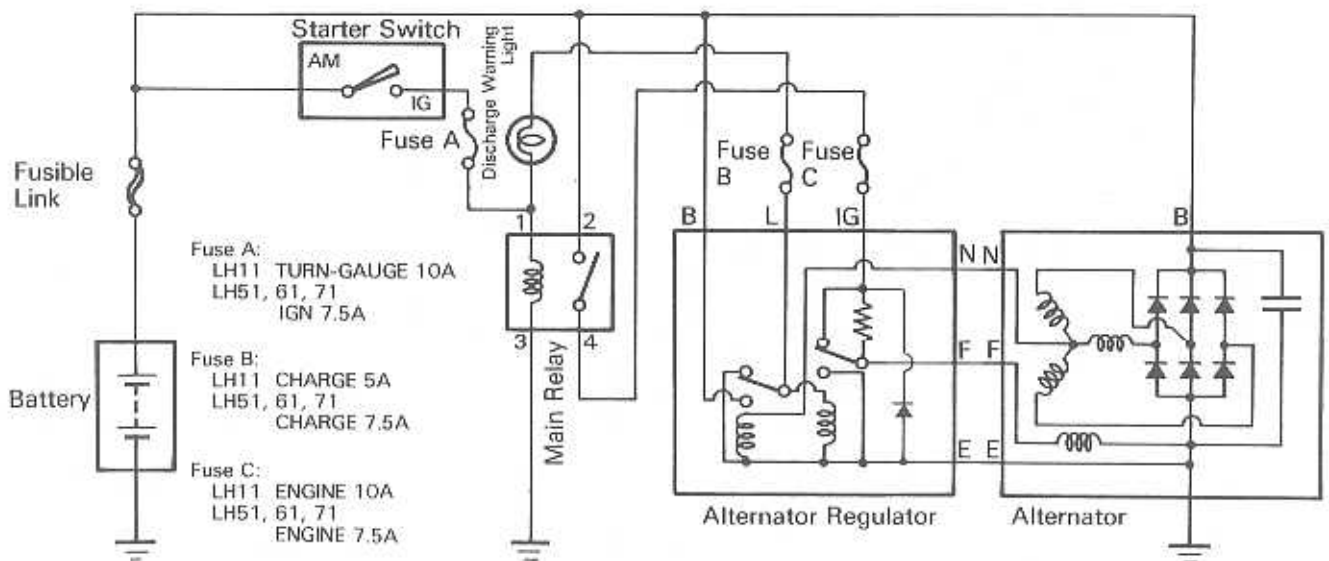

CHARGING SYSTEM CIRCUIT (Cont'd)

w/o IC Regulator [LN, LS]

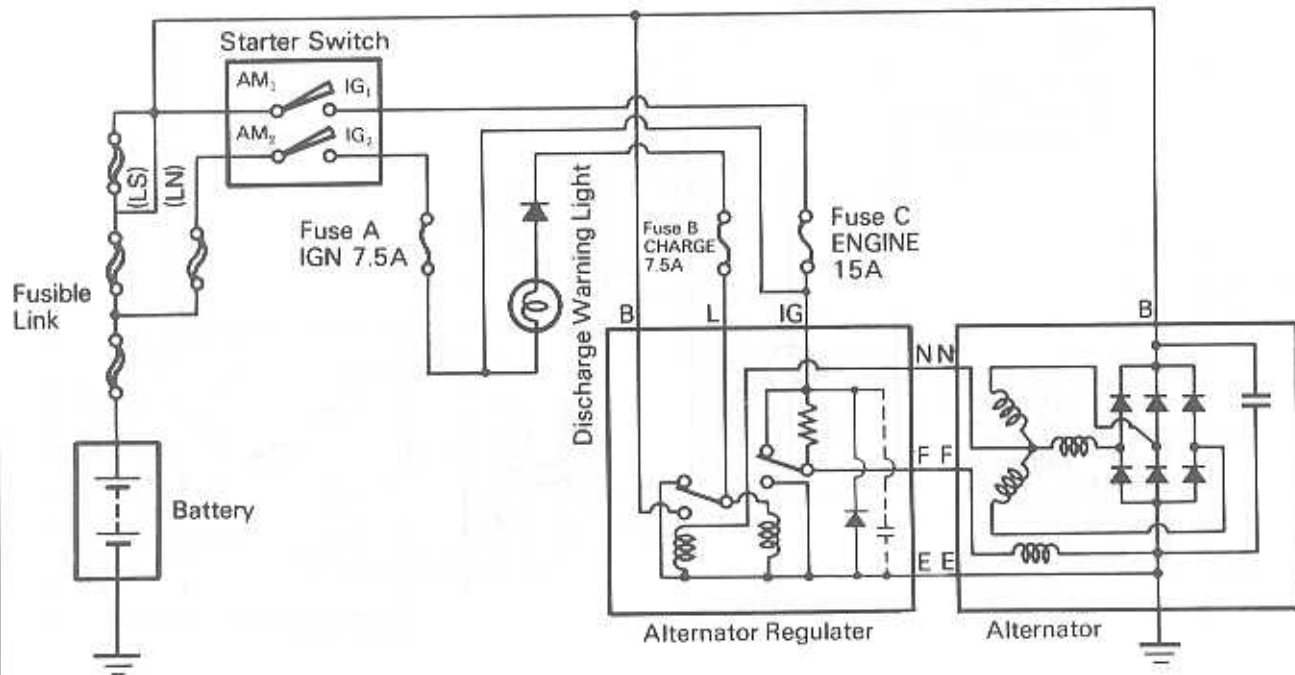

w/ IC Regulator [LX]

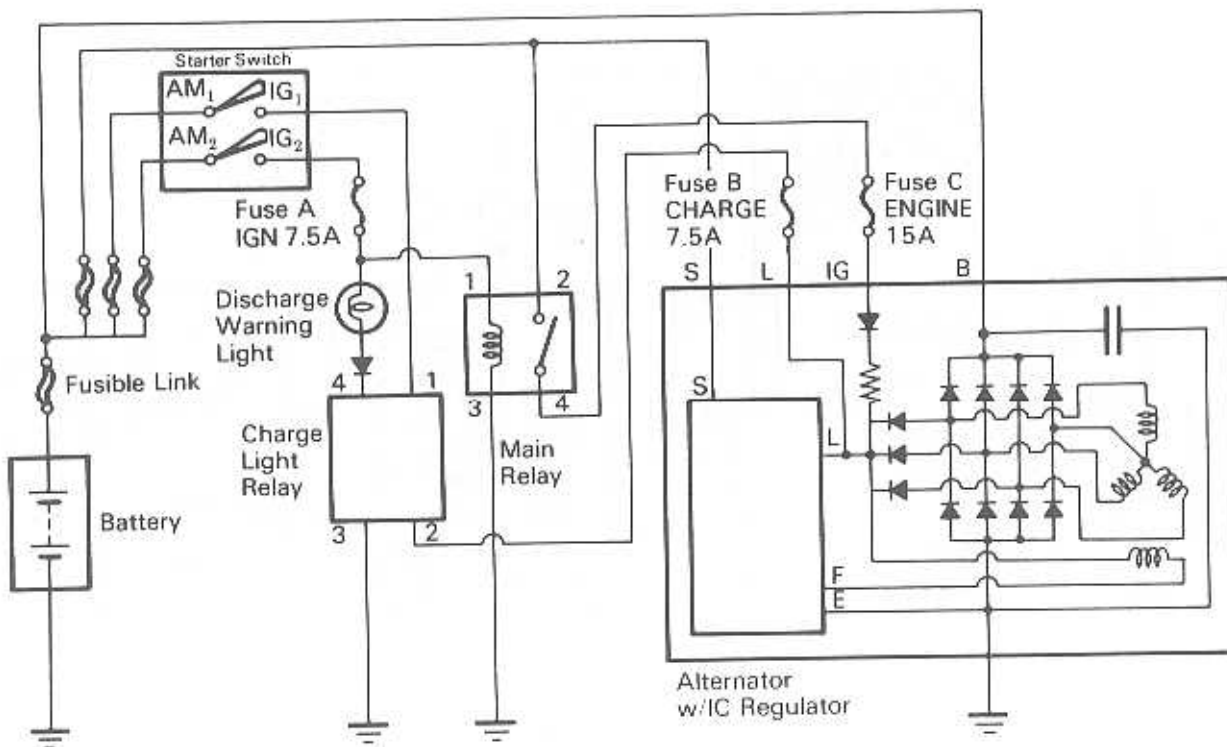

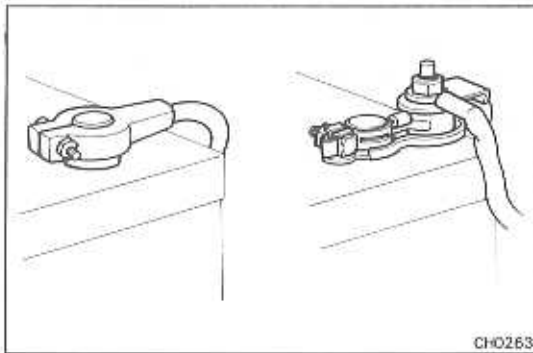
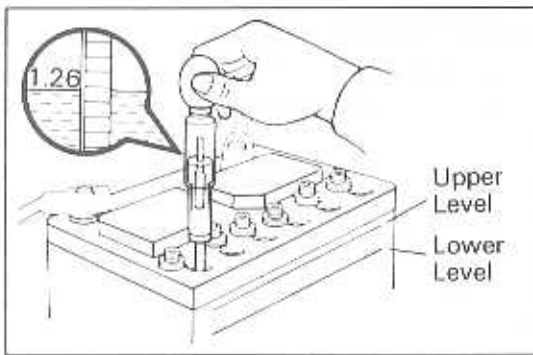

CH0263

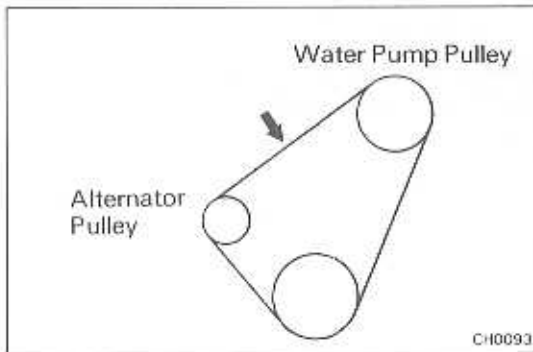

CH0093

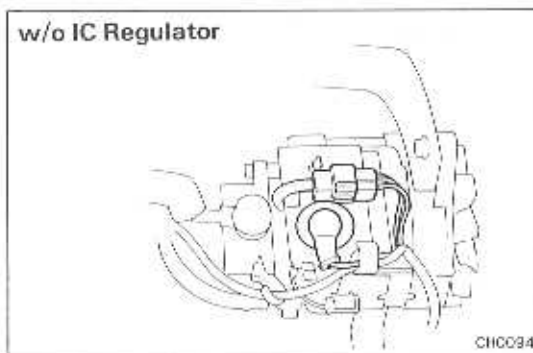

CH0094

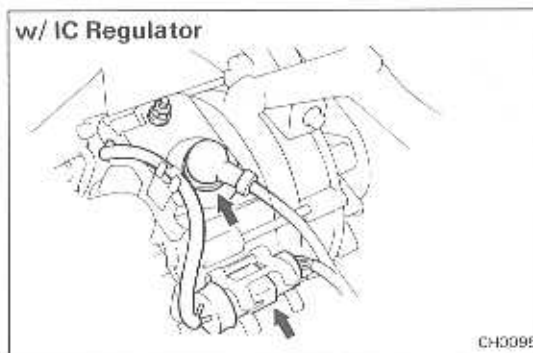

CH0095

ON-VEHICLE INSPECTION

1. INSPECT BATTERY SPECIFIC GRAVITY

- (a) Check the specific gravity of each cell.

Standard specific gravity:

When fully charged at 20°C (68°F)

1.25 – 1.27 (ex. NX110, 120, 200, 125D38L)

1.27 – 1.29 (NX110, 120, 200, 125D38L)

- (b) Check the electrolyte quantity of each cell.
If insufficient, refill with distilled (or purified) water.

2. CHECK BATTERY TERMINALS, FUSIBLE LINKS AND FUSES

- (a) Check that the battery terminals are not loose or corroded.
(b) Check the fusible link and fuses for continuity.

3. INSPECT DRIVE BELT

Check the drive belt deflection by pressing on the belt at the points indicated in the figure with 10 kg (22.0 lb, 98 N) of pressure.

Drive belt deflection:

New belt 7 – 10 mm (0.28 – 0.39 in.)

Used belt 10 – 15 mm (0.39 – 0.59 in.)

If necessary, adjust the drive belt deflection.

NOTE:

- "New belt" refers to a belt which has never been used.
- "Used belt" refers to a belt which has been used on a running engine for 5 minutes or more.

4. VISUALLY CHECK ALTERNATOR WIRING AND LISTEN FOR ABNORMAL NOISES

- (a) Check that the wiring is in good condition.
(b) Check that there are no abnormal noise from the alternator while the engine is running.

5. INSPECT CHARGE LIGHT CIRCUIT

- (a) Warm up the engine and then turn it off.
(b) Turn off all accessories.
(c) Turn the starter switch to "ON". Check that the charge light is lit.
(d) Start the engine. Check that the light goes out.

If the light does not operate as described, troubleshoot the charge light circuit.

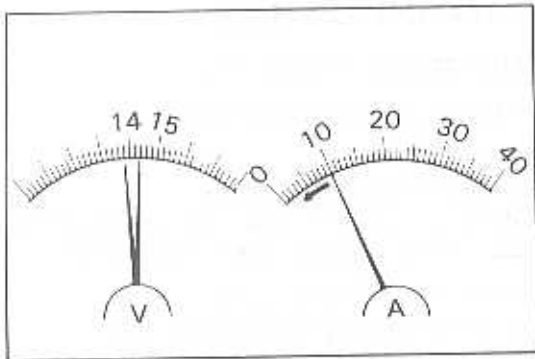

6. INSPECT CHARGING CIRCUIT WITHOUT LOAD

NOTE: If a battery/alternator tester is available, connect the tester to the charging circuit as per the manufacturer's instructions.

- (a) If a tester is not available, connect a voltmeter and ammeter to the charging circuit as follows:
- Disconnect the wire from terminal B of the alternator and connect the wire to the negative terminal of the ammeter.
 - Connect the test lead from the positive terminal of the ammeter to terminal B of the alternator.
 - Connect the positive lead of the voltmeter to terminal B of the alternator.
 - Ground the negative lead of the voltmeter.

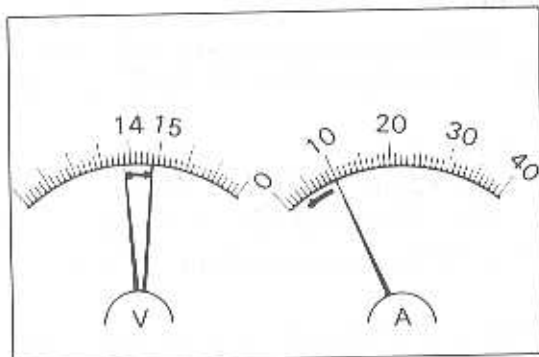

- (b) Check the charging circuit as follows:

With the engine running from idle to 2,000 rpm, check the reading on the ammeter and voltmeter.

[w/o IC REGULATOR]

Standard amperage: Less than 10A
Standard voltage: 13.8 – 14.8V

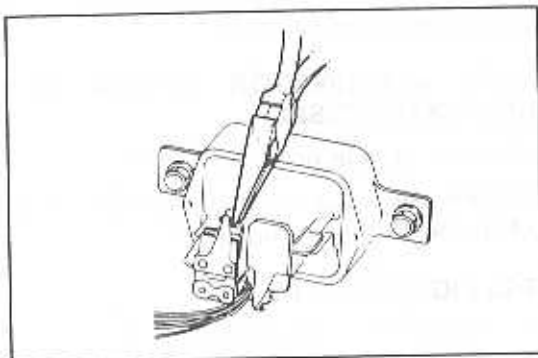

If the reading is not within standard voltage, adjust the regulator or replace it.

[w/ IC REGULATOR]

Standard amperage: Less than 10A
Standard voltage: 13.8 – 14.4V (25°C or 77°F)

If the voltage reading is more than standard voltage, replace the IC regulator.

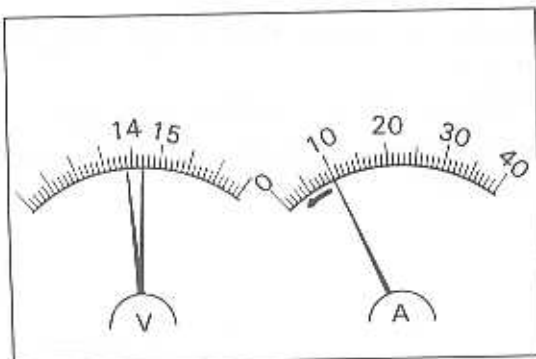

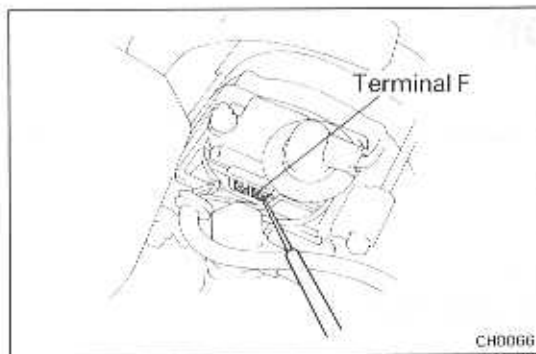

If the voltage reading is less than standard voltage, check the IC regulator and alternator as follows:

- Remove the brush holder cover and connect the terminal B wire to the original position.

CAUTION: Battery voltage is applied to terminal B, so disconnect the battery before beginning work.

- With terminal F grounded, start the engine and check the reading on the voltmeter.

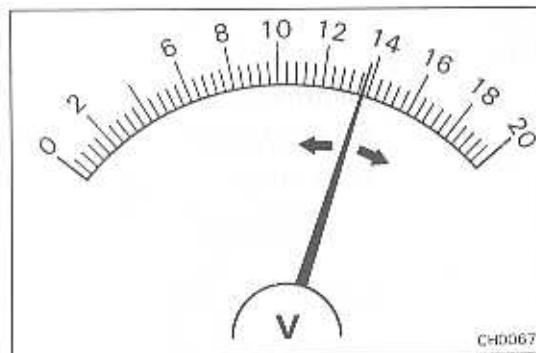

If the voltage reading is more than standard voltage, replace the IC regulator.

If the voltage reading is less than standard voltage, check the alternator.

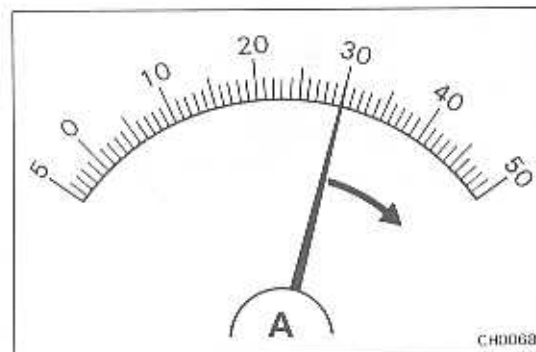

7. CHECK CHARGING CIRCUIT WITH LOAD

- With the engine running at 2,000 rpm, turn on the high beam headlights and place the heater fan control switch at "HI".
- Check the reading on the ammeter.

Standard amperage: More than 30A

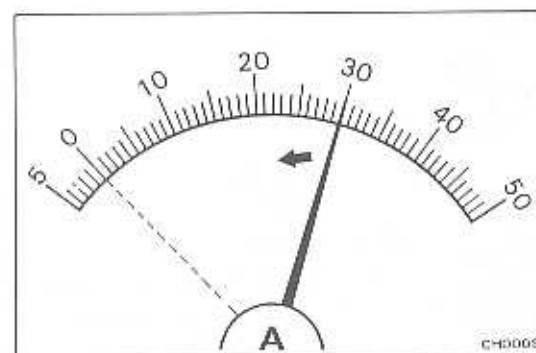

If the ammeter reading is less than 30A, repair the alternator. (See page CH-8)

NOTE: If the battery is fully charged, the indication will sometimes be less than 30A.

ALTERNATOR COMPONENTS

w/o IC Regulator (w/ Small Vacuum Pump)

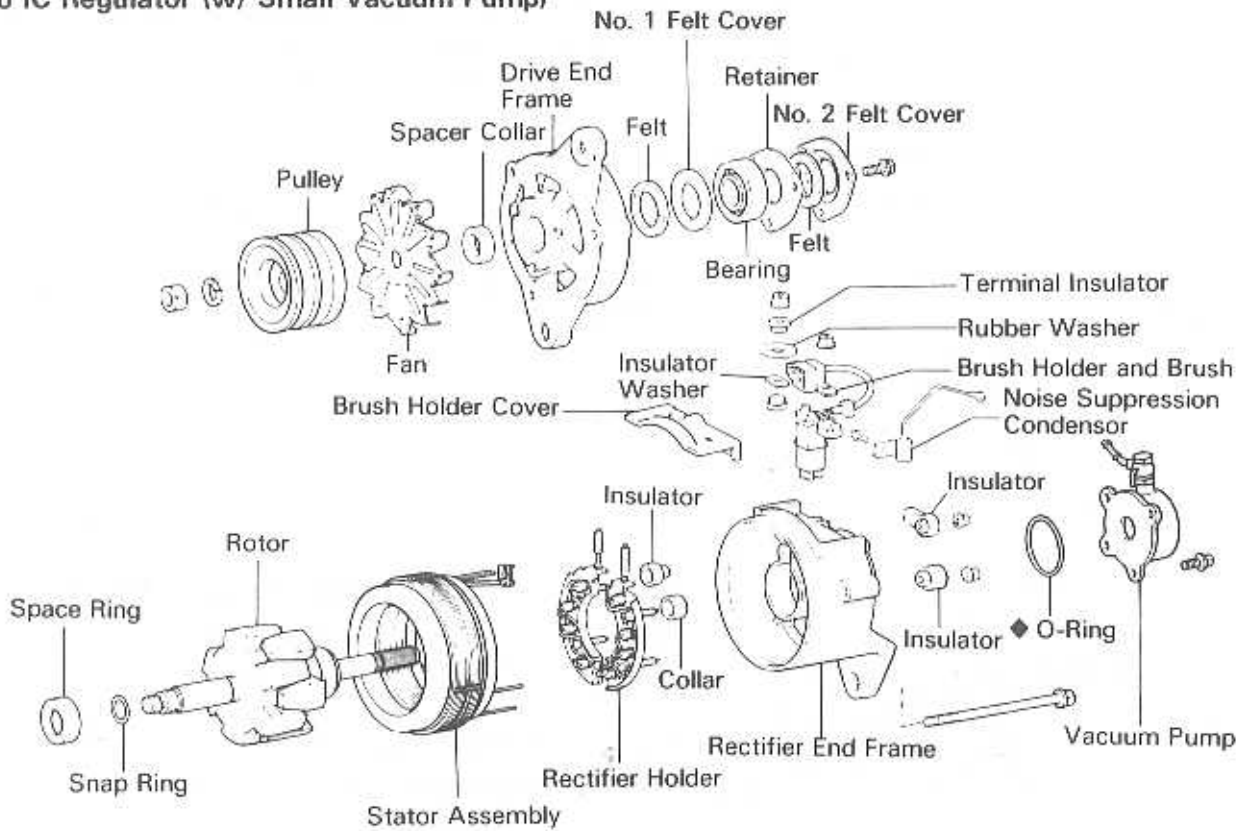

w/o IC Regulator (w/ Large Vacuum Pump)

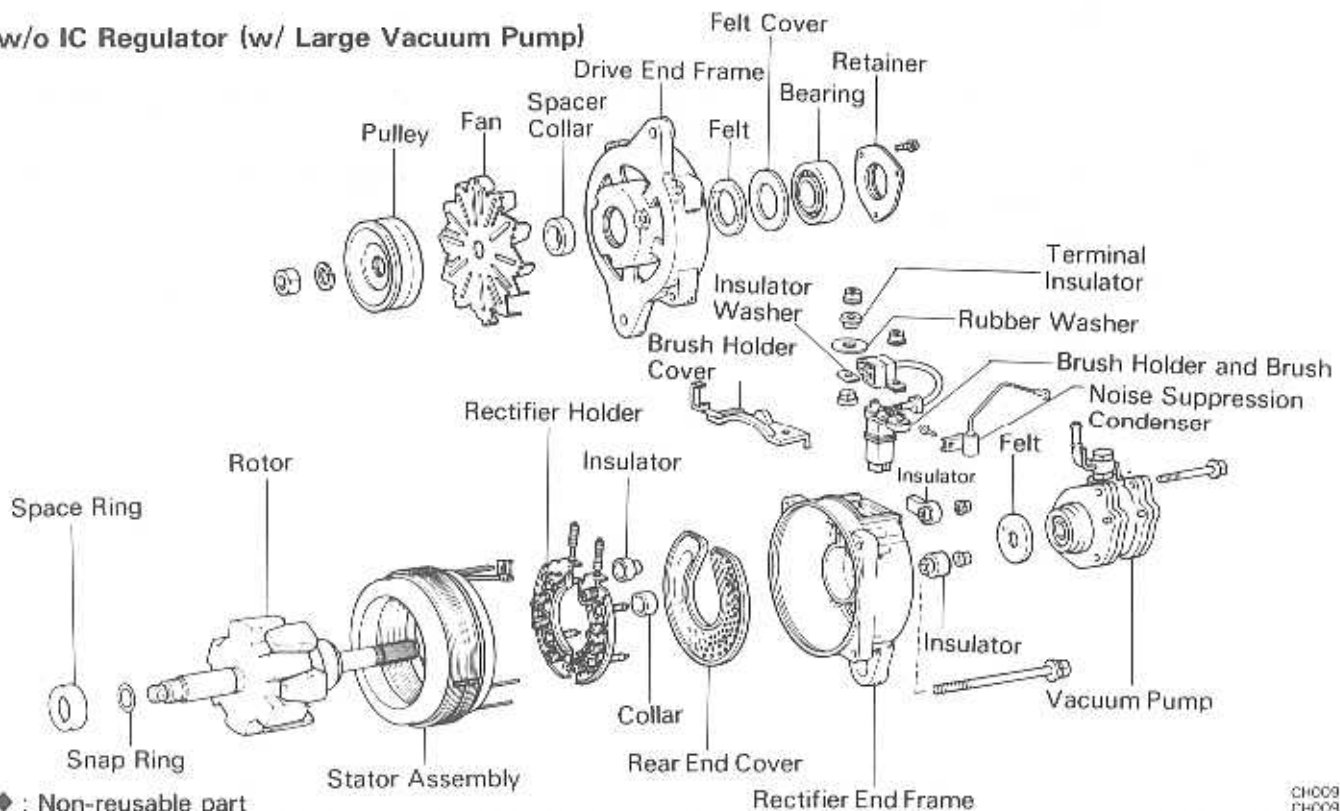

◆ : Non-reusable part

COMPONENTS (Cont'd)

W/ IC Regulator

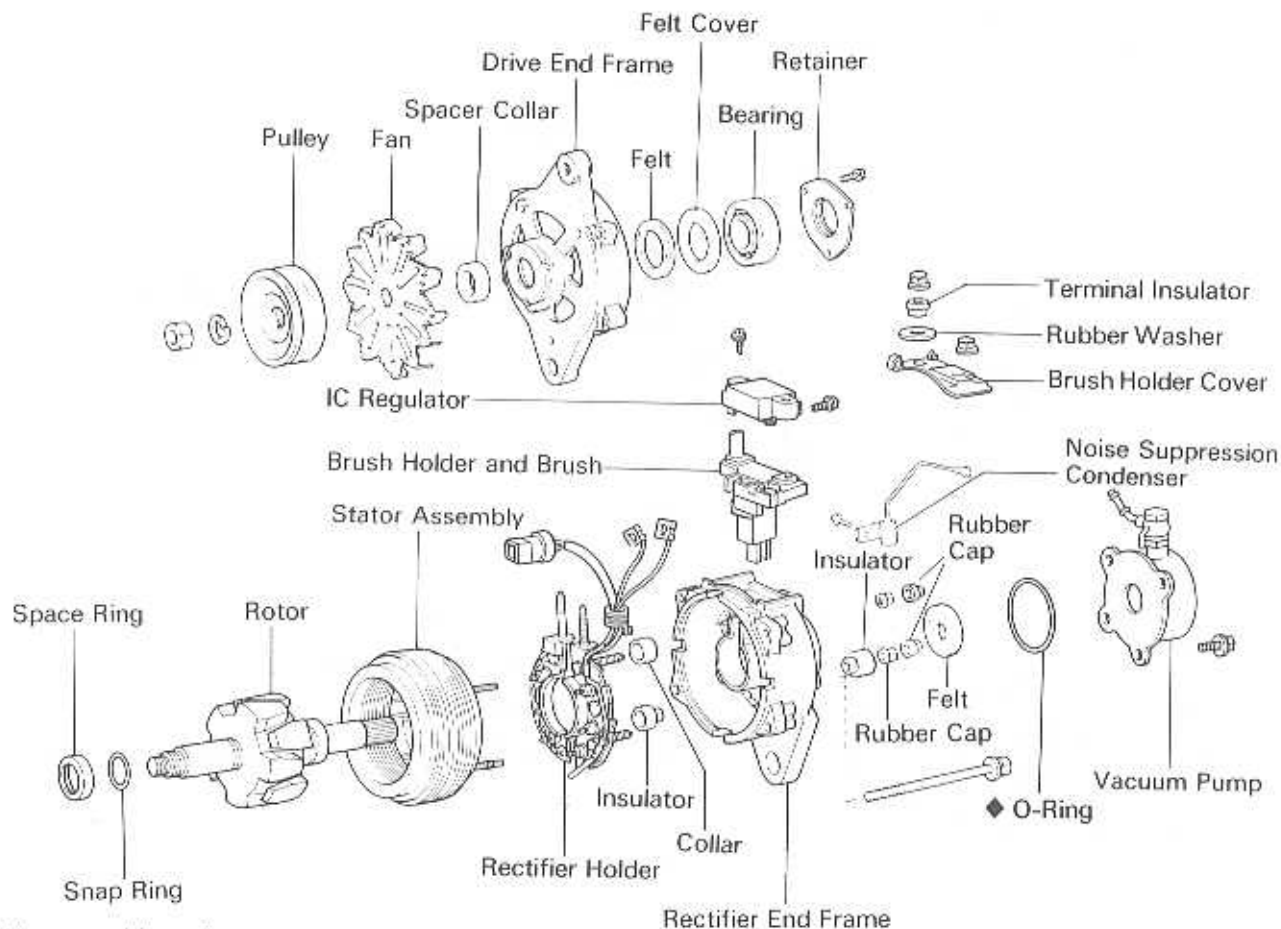

◆ : Non-reusable part

CH0098

DISASSEMBLY OF ALTERNATOR

1. REMOVE VACUUM PUMP
[w/ Small Vacuum Pump]

Remove the three bolts, vacuum pump and O-ring.

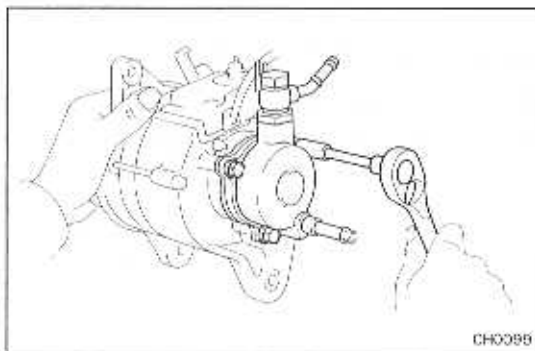

CH0099

[w/ Large Vacuum Pump]

Remove the three through bolts, vacuum pump and felt.

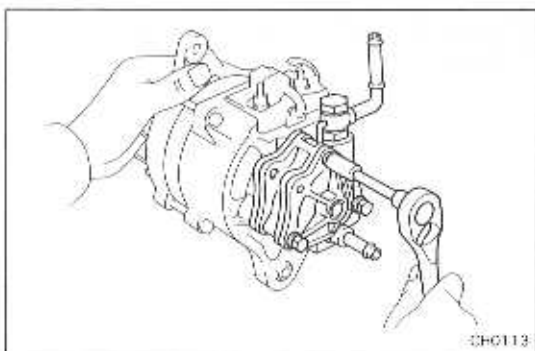

CH0113

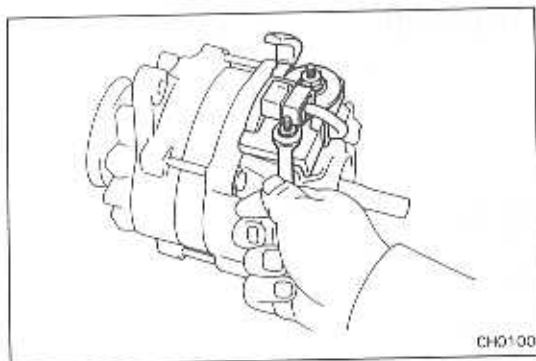

2. REMOVE BRUSH HOLDER COVER
[w/o IC Regulator]

Remove the two nuts, terminal insulator, rubber washer, wire clamp, cover and insulator washer.

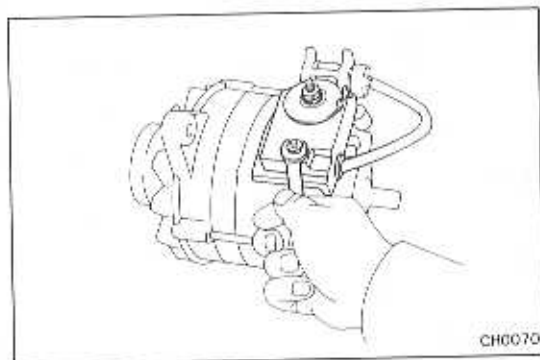

[w/ IC Regulator]

Remove the two nuts, terminal insulator, rubber washer and cover.

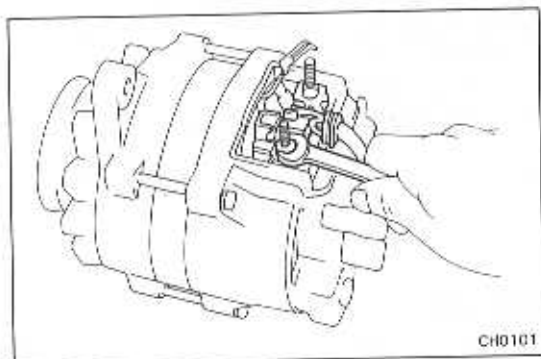

3. [w/o IC REGULATOR]
REMOVE BRUSH HOLDER

- (a) Disconnect the lead wire.
- (b) Remove the nut and brush holder.

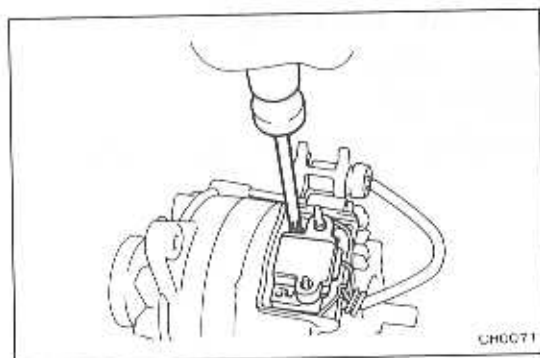

[w/ IC REGULATOR]
REMOVE BRUSH HOLDER AND IC REGULATOR

- (a) Remove the screw and disconnect the blue lead wire.
- (b) Pull out the brush holder with the IC regulator from the rectifier holder.

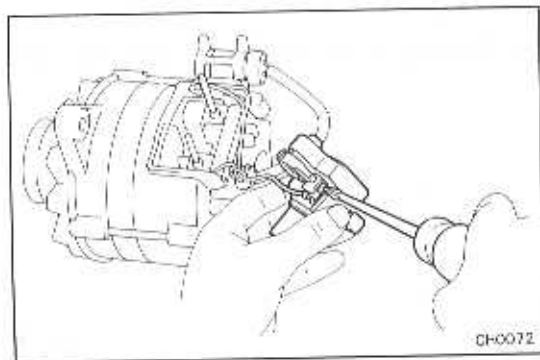

- (c) Remove the screw and disconnect the lead wire from the brush holder.

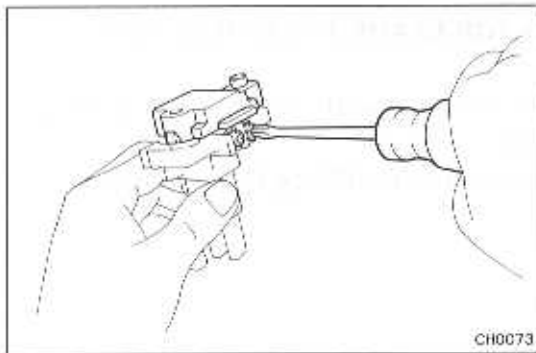

- (d) Remove the two screws and separate the IC regulator and brush holder.

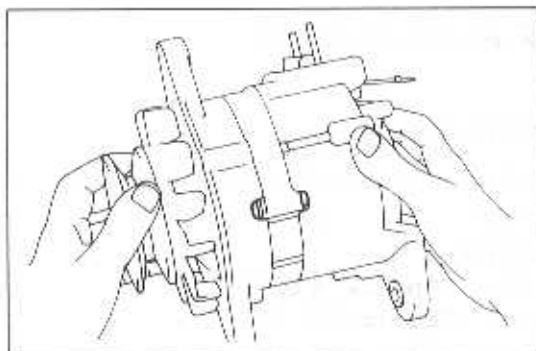

4. REMOVE DRIVE END FRAME WITH ROTOR FROM STATOR

- (a) **[w/ Small Vacuum Pump]**
Remove the three through bolts.
[w/ Large Vacuum Pump]
Remove the four through bolts.

- (b) Remove the end frame with the rotor.

NOTE: If necessary, lightly tap the rotor shaft with a plastic-face hammer.

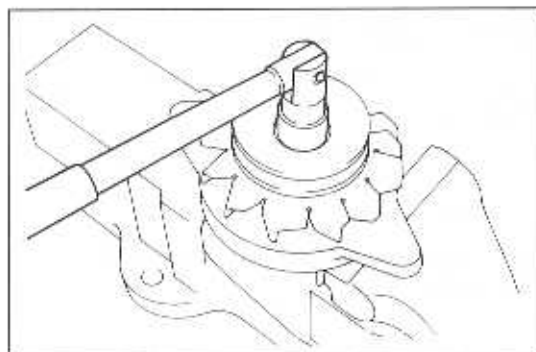

5. REMOVE PULLEY AND FAN

- (a) Mount the rotor in a soft jaw vise.
(b) Remove the pulley nut, spring washer pulley and fan.

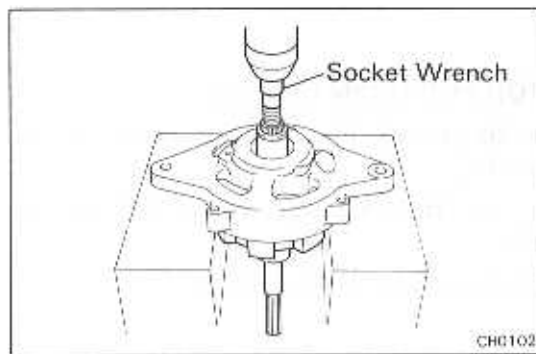

6. REMOVE ROTOR

- (a) Using a socket wrench and press, press out the rotor, spacer ring and collar.
(b) Remove the snap ring from the rotor shaft.

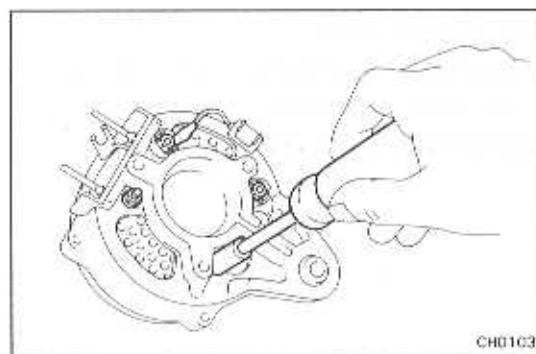

7. REMOVE STATOR WITH RECTIFIER HOLDER

- (a) **[w/ IC Regulator]**
Remove the two rubber caps.
(b) Remove the four nuts, two terminal insulators and stator with the rectifier holder.
(c) **[w/o IC Regulator (w/ Small Vacuum Pump)]**
Remove the rear end cover from the rectifier holder.
(d) Remove the two insulators and two collars from the rectifier holder studs.

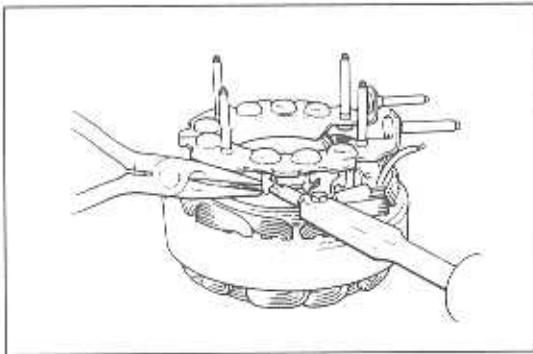

8. UNSOLDER STATOR LEADS FROM RECTIFIER HOLDER

Hold the rectifier terminal with needle-nose pliers and unsolder the leads.

CAUTION: Protect the rectifiers from heat.

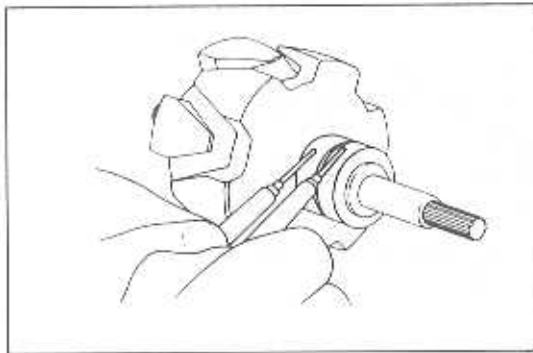

INSPECTION OF ALTERNATOR

Rotor

1. INSPECT ROTOR FOR OPEN CIRCUIT

Using an ohmmeter, check that there is continuity between the slip rings.

Standard resistance:

w/o IC Regulator Approx. 4.0 Ω

w/ IC Regulator Approx. 2.9 Ω

If there is no continuity, replace the rotor.

2. INSPECT ROTOR FOR GROUND

Using an ohmmeter, check that there is no continuity between the slip ring and rotor.

If there is continuity, replace the rotor.

3. INSPECT SLIP RINGS

Check that the slip rings are not rough or scored. If necessary, replace the rotor.

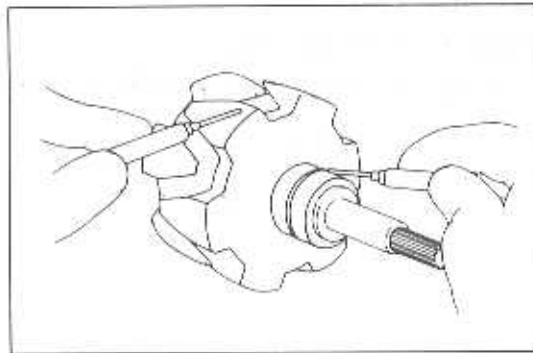

Stator

1. INSPECT STATOR FOR OPEN CIRCUIT

Using an ohmmeter, check that there is continuity between the coil leads.

NOTE: At this time, the meeting wires should be connected with solder.

If there is no continuity, replace the stator.

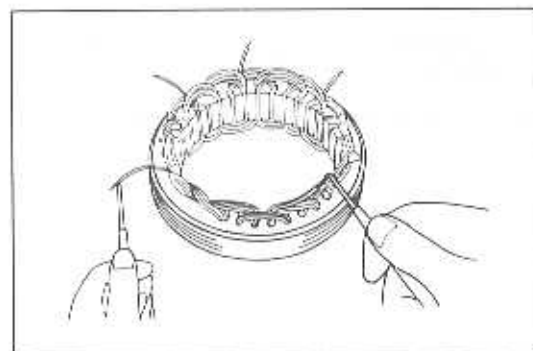

2. INSPECT ROTOR FOR GROUND

Using an ohmmeter, check that there is no continuity between the coil leads and stator core.

If there is continuity, replace the stator.

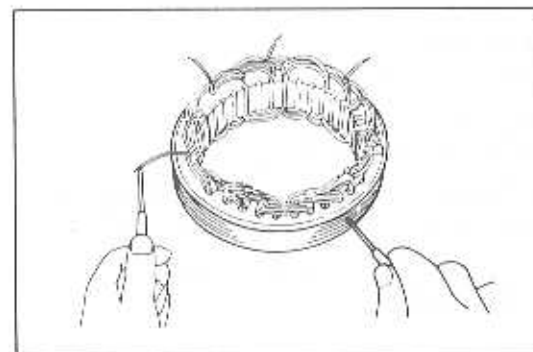

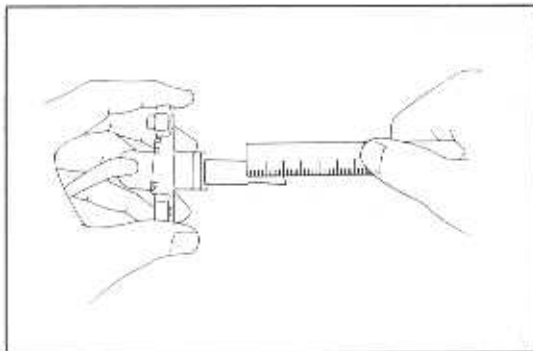

Brush and Brush Holder

1. INSPECT BRUSH LENGTH

Using a scale, measure into the brush length.

Standard length: 20 mm (0.79 in.)

Minimum length: 5.5 mm (0.217 in.)

If the brush length is less than minimum, replace the brush.

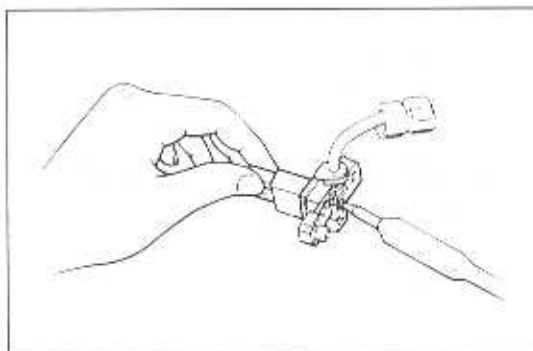

2. IF NECESSARY, REPLACE BRUSH

(a) Unsolder and remove the brush and spring.

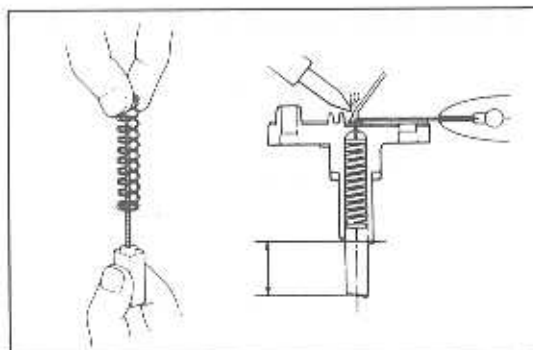

(b) Insert the brush wire through the spring.

(c) Install the brush in the brush holder.

(d) Solder the wire to the brush holder at the standard length.

Standard length: 20 mm (0.79 in.)

(e) Check that the brush moves smoothly in the brush holder.

(f) Cut off any excess wire.

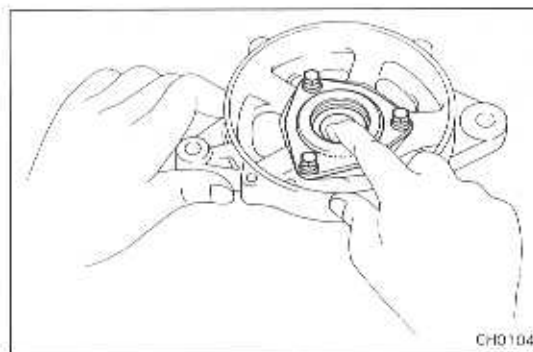

Bearing

1. INSPECT BEARING

Check the bearing for roughness.

If rough, replace the bearing.

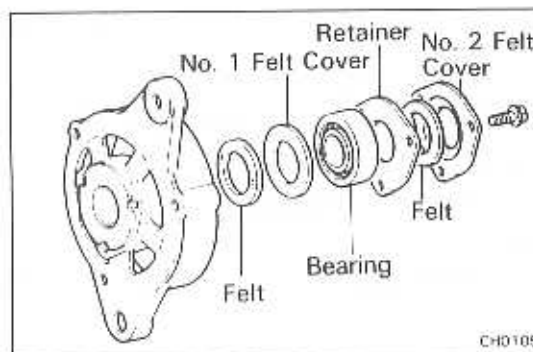

2. IF NECESSARY, REPLACE BEARING

(a) Remove the following parts:

- (1) Three bolts
- (2) No. 2 felt cover (w/ Small vacuum pump)
- (3) Felt (w/ Small vacuum pump)
- (4) Retainer
- (5) Bearing
- (6) No. 1 felt cover
- (7) Felt

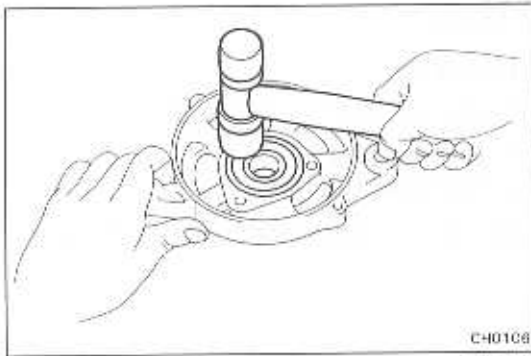

(b) Install the following parts:

- (1) Felt
- (2) No.1 felt cover
- (3) Bearing
If necessary, lightly tap the bearing with a plastic-face hammer.
- (4) Retainer
- (5) Felt (w/ Small vacuum pump)
- (6) No. 2 felt cover (w/ Small vacuum pump)
- (7) Three bolts

ASSEMBLY OF ALTERNATOR

(See page CH-8)

1. SOLDER EACH STATOR LEAD TO RECTIFIER HOLDER

Hold the rectifier terminal with needle-nose pliers while soldering the leads.

CAUTION: Protect the rectifiers from heat.

2. ASSEMBLE RECTIFIER END FRAME AND RECTIFIER HOLDER

- (a) Place the two inner terminal insulators on the positive side studs.
- (b) Place the collars on the negative side studs.

(c) [w/o IC Regulator (w/ Large Vacuum Pump)]
Place the rear end cover on the studs.

- (d) Install the rectifier end frame on the rectifier holder.
- (e) Check that the wires are not touching the case.

(f) Place the two outer terminal insulators on the positive side studs.

(g) Install the lead wire of the noise suppression condenser on the top positive side studs. (w/ Noise suppression condenser)

(h) Install the four nuts on the studs.

(i) [w/ IC Regulator]
Install the two rubber caps on the positive side studs.

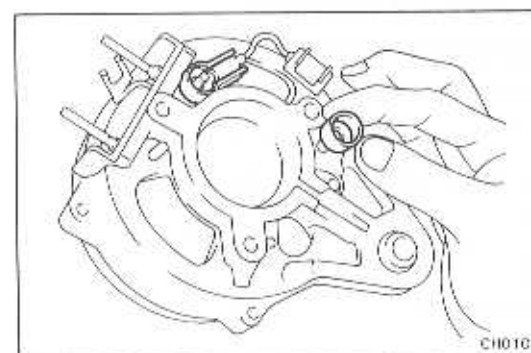
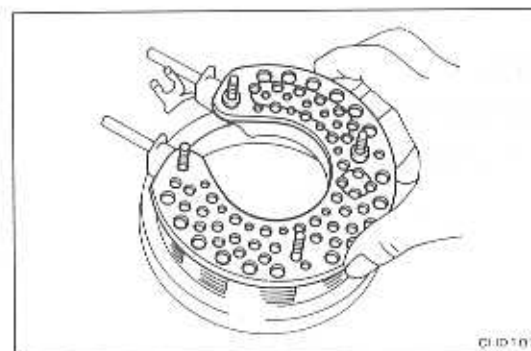
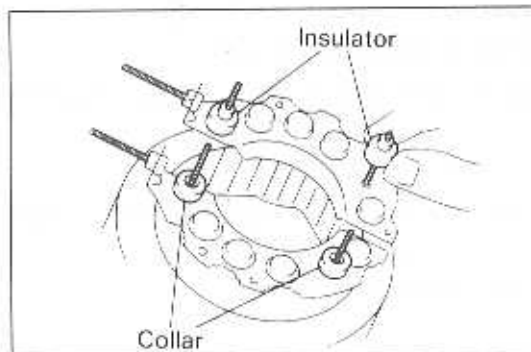
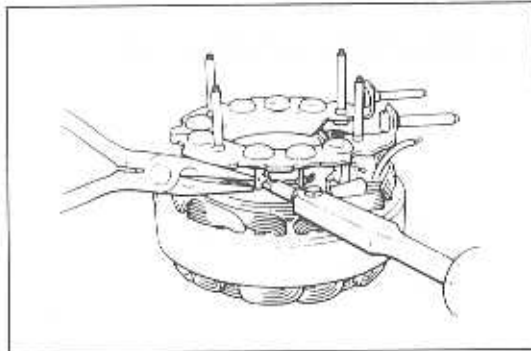

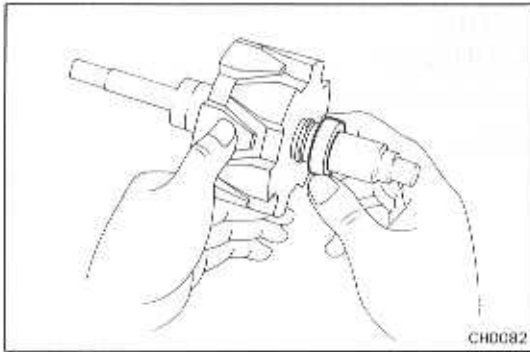

3. INSTALL ROTOR

- (a) Install the snap ring on rotor shaft groove.
- (b) Install the space ring on the rotor shaft.

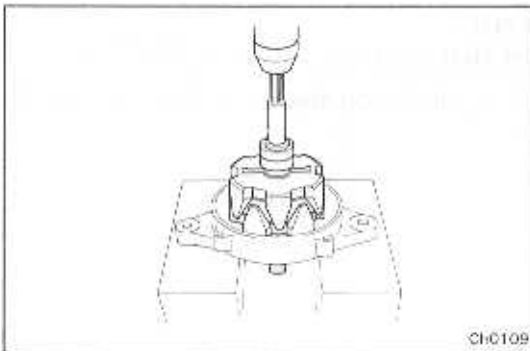

- (c) Using a press, press in the rotor.

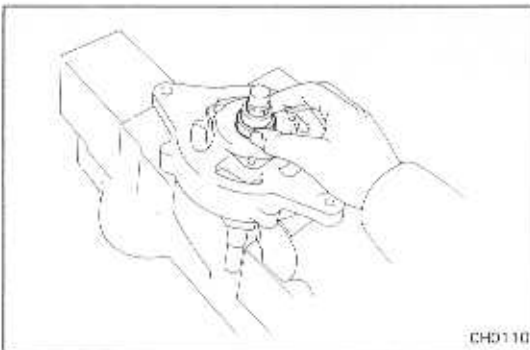

- (d) Install the spacer collar.

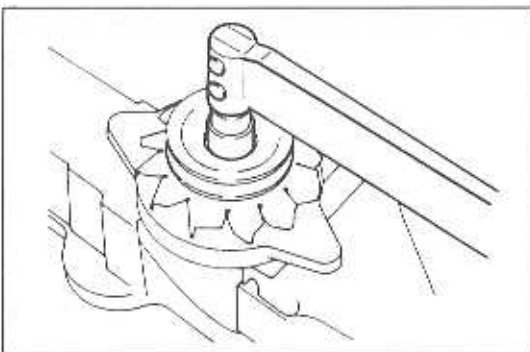

4. INSTALL FAN AND PULLEY

- (a) Mount the rotor in a soft-jaw vise.
- (b) Slide the fan, pulley and spring washer onto the shaft.
- (c) Install and torque the pulley nut.

Torque: 900 kg-cm (65 ft-lb, 88 N·m)

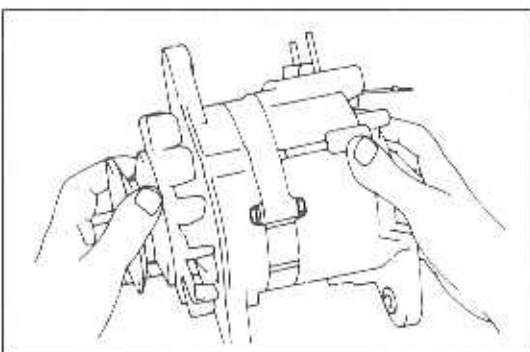

5. ASSEMBLE DRIVE END FRAME AND RECTIFIER END FRAME

- (a) Assemble the drive end frame and rectifier end frame.
- (b) [w/ Small Vacuum Pump]
Install the three through bolts.
[w/ Large Vacuum Pump]
Install the four through bolts.
- (c) Make sure the rotor rotates smoothly.

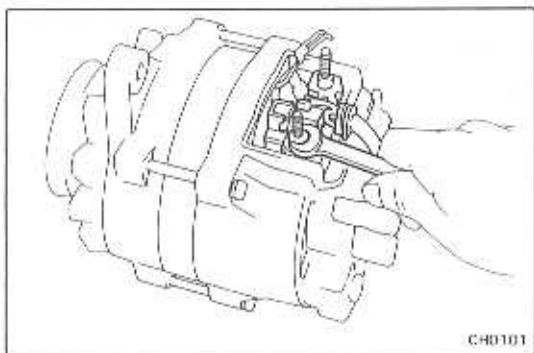

6. [w/o IC REGULATOR]
INSTALL BRUSH HOLDER

- (a) Install the brush holder with the nut.
- (b) Connect the lead wire to terminal B.

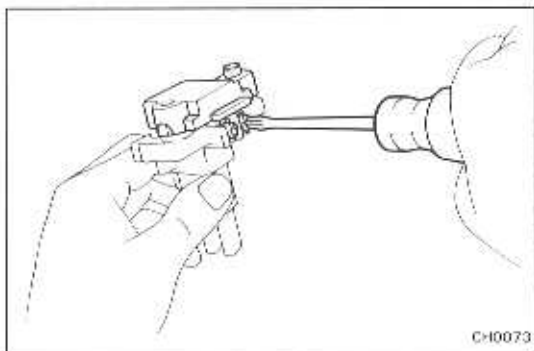

[w/ IC REGULATOR]
INSTALL BRUSH HOLDER AND IC REGULATOR

- (a) Install the IC regulator on the brush holder with the two screws.

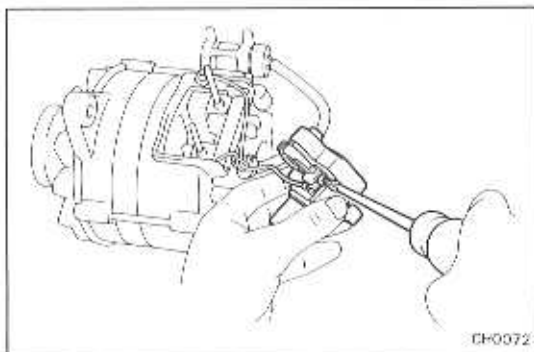

- (b) Connect the white lead wire to the terminal of the IC regulator with the screw.

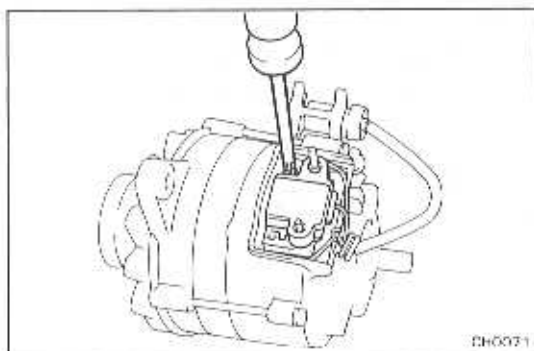

- (c) Install the brush holder and blue lead wire with the screw.

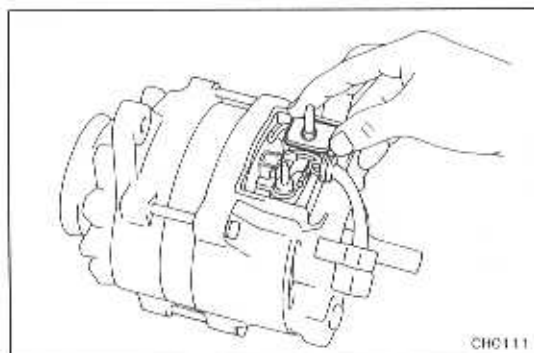

7. **INSTALL BRUSH HOLDER COVER**
 [w/o IC Regulator]

- (a) Place the insulator washer on terminal B.

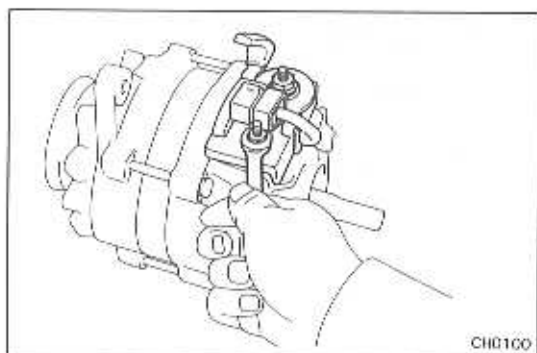

- (b) Place the cover on the rectifier end frame.
- (c) Place the terminal insulator and rubber washer on terminal B.
- (d) Place the wire clamp on terminal E.
- (e) Install the two nuts.

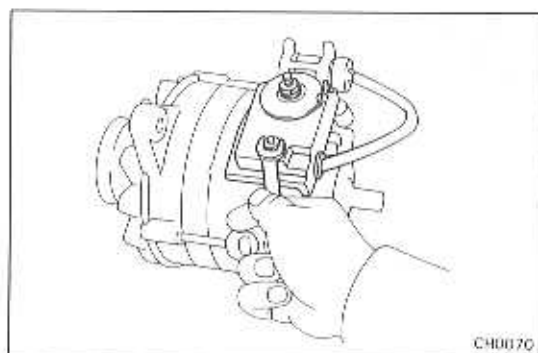

[w/ IC Regulator]

- (a) Place the cover on the rectifier end frame.
- (b) Place the terminal insulator and rubber washer on terminal B.
- (c) Install the two nuts.

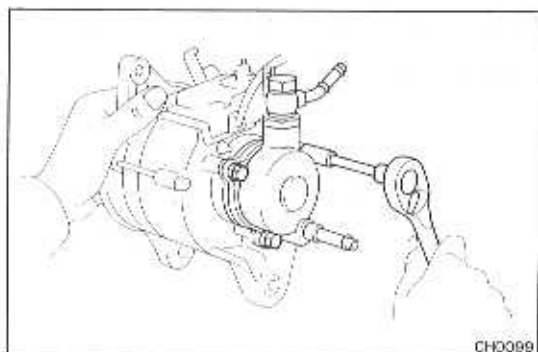

8. INSTALL VACUUM PUMP
[w/ Small Vacuum Pump]

- (a) Place a new O-ring on the rectifier end frame.
- (b) Install the vacuum pump with the three bolts. Torque the bolts.

Torque: 80 kg-cm (69 in.-lb, 7.8 N·m)

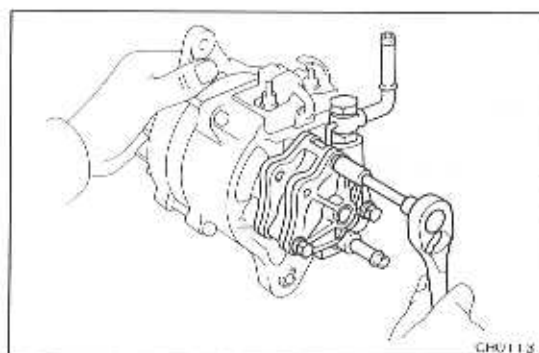

[w/ Large Vacuum Pump]

- (a) Place the felt on the rectifier end frame.
- (b) Install the vacuum pump with the three through bolts. Torque the bolts.

Torque: 80 kg-cm (69 in.-lb, 7.8 N·m)

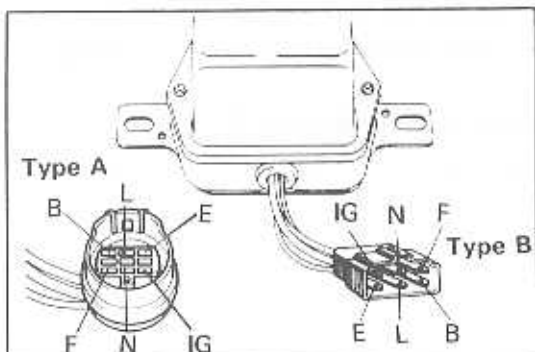

ALTERNATOR REGULATOR

INSPECTION OF ALTERNATOR REGULATOR

1. DISCONNECT REGULATOR CONNECTOR
2. REMOVE TWO MOUNTING BOLTS AND REGULATOR

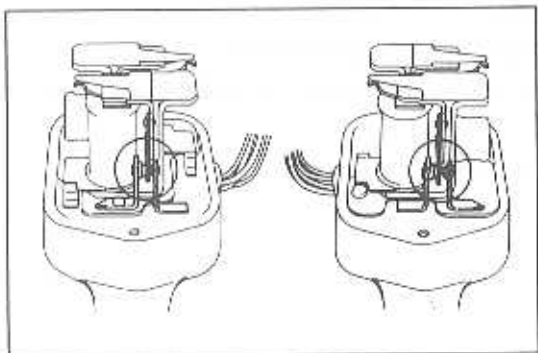

3. INSPECT POINT SURFACES FOR BURN OR DAMAGE
If defective, replace the regulator.

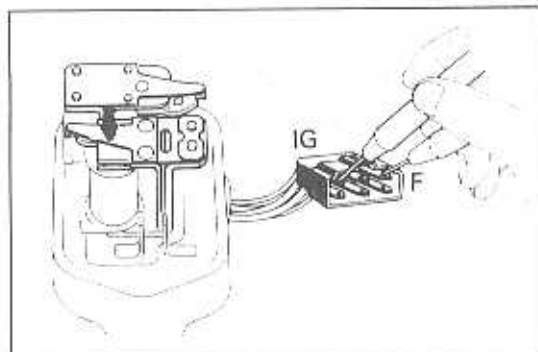

4. MEASURE RESISTANCE BETWEEN TERMINALS

- (a) Using an ohmmeter, measure the resistance between terminals IG and F.

Resistance (voltage regulator):

At rest 0 Ω
Pulled in Approx. 11 Ω

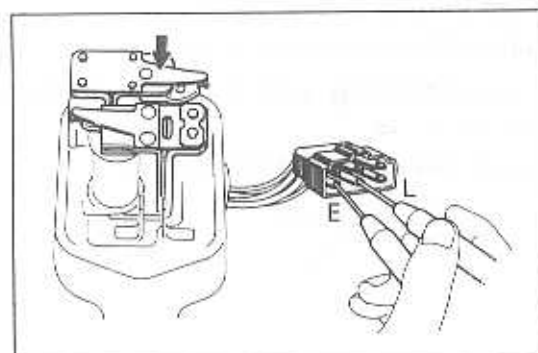

- (b) Using an ohmmeter, measure the resistance between terminals L and E.

Resistance (voltage relay):

At rest 0 Ω
Pulled in Approx. 100 Ω

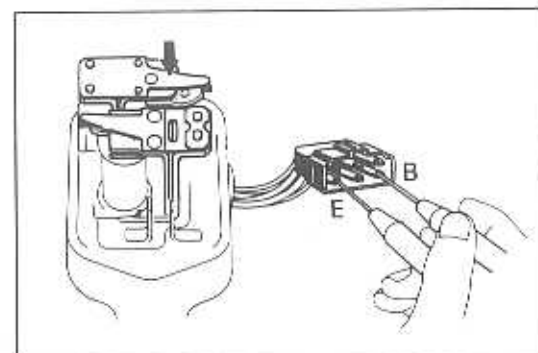

- (c) Using an ohmmeter, measure the resistance between terminals B and E.

Resistance (voltage relay):

At rest Infinity
Pulled in Approx. 100 Ω

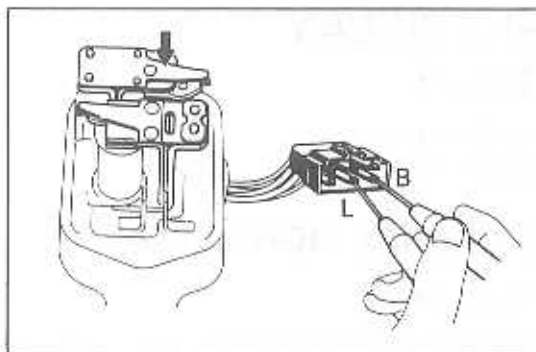

- (d) Using an ohmmeter, measure the resistance between terminals B and L.

Resistance (voltage relay):

At rest Infinity
 Pulled in 0 Ω

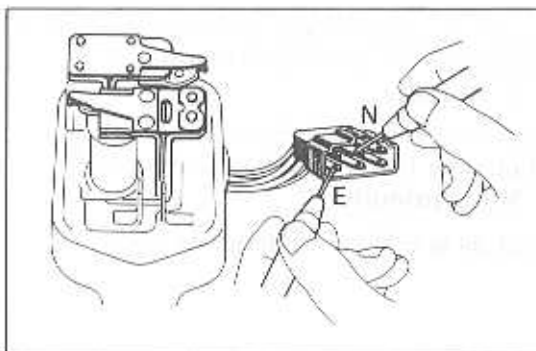

- (e) Using an ohmmeter, measure the resistance between terminals N and E.

Resistance: Approx. 24 Ω

If any of the above checks are not as specified, replace the alternator regulator.

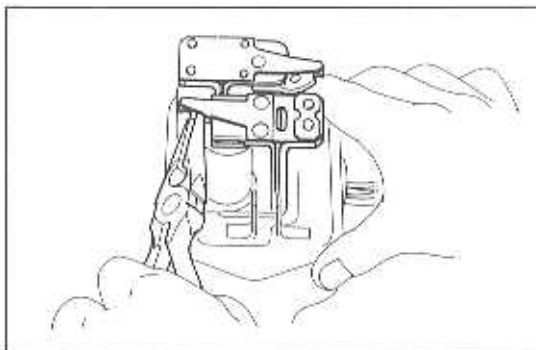

VOLTAGE ADJUSTMENT OF ALTERNATOR REGULATOR

1. TO ADJUST VOLTAGE REGULATOR, BEND REGULATOR ADJUSTING ARM

Regulating voltage: 13.8 – 14.8 V

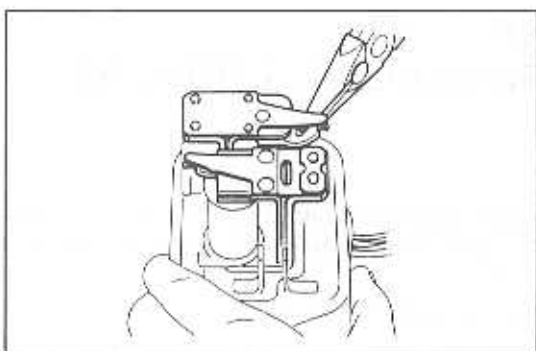

2. TO ADJUST VOLTAGE RELAY, BEND RELAY ADJUSTING ARM

Relay actuating voltage: 4.0 – 5.8 V

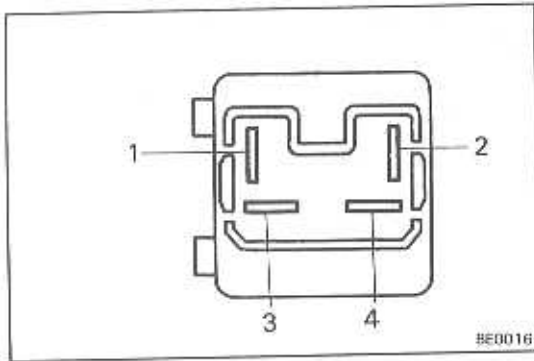

CHARGE LIGHT RELAY [w/ IC Regulator]

LOCATION: LHD In the left cowl.
RHD In the right cowl.

INSPECTION OF CHARGE LIGHT RELAY

INSPECT CHARGE LIGHT RELAY

Apply battery voltage between terminals 1, 2 and 3.

• 3 ↔ 4

Battery positive (+) terminal to terminal 1 and 2

Battery negative (-) terminal to terminal 3

Continuity

Battery positive (+) terminal to terminal 1

Battery negative (-) terminal to terminal 3

No continuity

If continuity is not as specified, replace the relay.

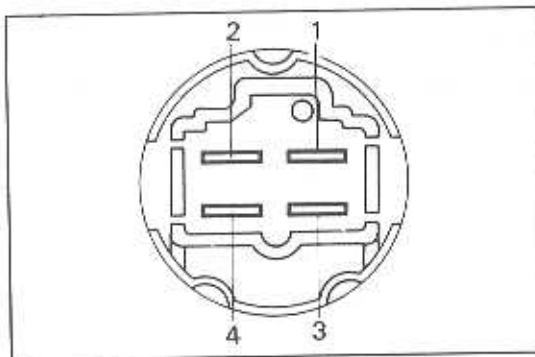

MAIN RELAY [LH11 (ex. Indonesia), LH51, 61, 71, LX]

LOCATION

LH11: Under the instrument panel on the driver's side.

LH51, 61, 71: Under the instrument panel in the relay box.

LX: In the engine compartment relay box.

INSPECTION OF MAIN RELAY

INSPECT MAIN RELAY

(a) Using an ohmmeter, check for continuity between the following terminals:

• 1 ↔ 3 **Continuity**

• 2 ↔ 4 **No continuity**

(b) Apply battery voltage between terminals 1 and 3.

• 2 ↔ 4 **Continuity**

If continuity is not as specified, replace the relay.

BODY ELECTRICAL SYSTEM

	Page
TIMING BELT WARNING	BE-2

BE

TIMING BELT WARNING

IF TIMING BELT WARNING LIGHT LIGHTS

NOTE: The timing warning light will come on every 100,000 km (60,000 miles).

1. REPLACE TIMING BELT (See page EM-20)

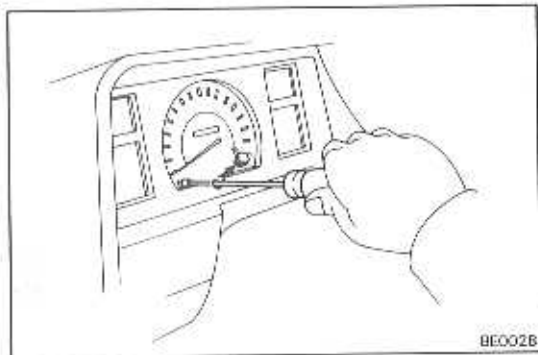

2. TURN OFF WARNING RESET SWITCH
 - (a) Remove the grommet from the speedometer.
 - (b) Turn off the warning light by pushing the warning reset switch.
 - (c) Install the grommet.

IF REPLACING TIMING BELT BEFORE WARNING LIGHT COMES ON

NOTE: Be sure to reset the timing belt interval counter back to the "0" position.

1. REMOVE SPEEDOMETER FROM COMBINATION METER

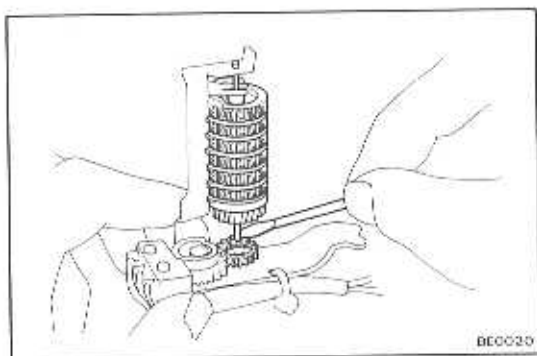

2. SET INTERVAL COUNTER [LS]

- (a) Remove the interval counter with the total counter.
- (b) Remove the E-ring and total counter.

NOTE: Do not touch the number wheels of the total counter.

- (c) Set the interval counter gear and interval switch as shown.

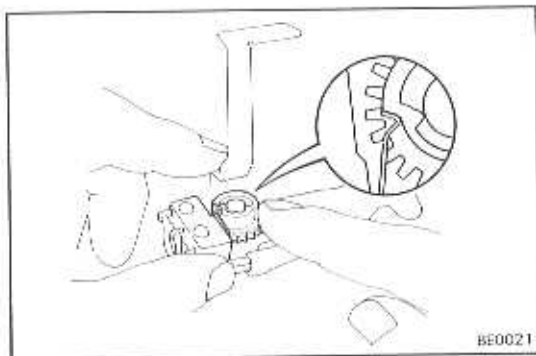

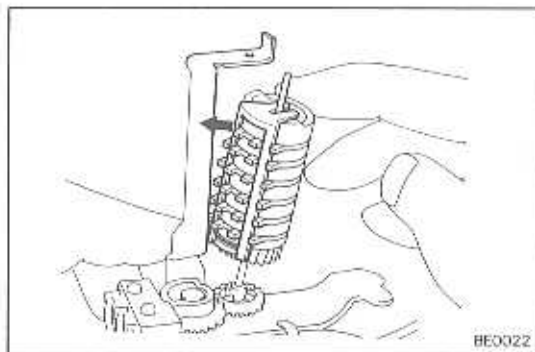

- (d) Align the claw of the total counter and bracket, and assemble.
- (e) Attach the turn gear and install the E-ring.

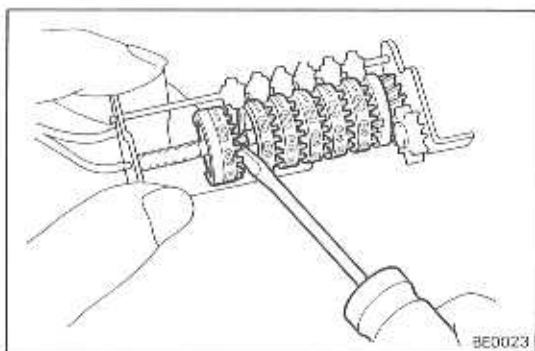

[LH51, 61, 71, LN]

- (a) Remove the interval counter assembly.
- (b) Set the number wheels so all the numbers facing the speedometer panel are at zero.
- (c) Install the interval counter assembly.

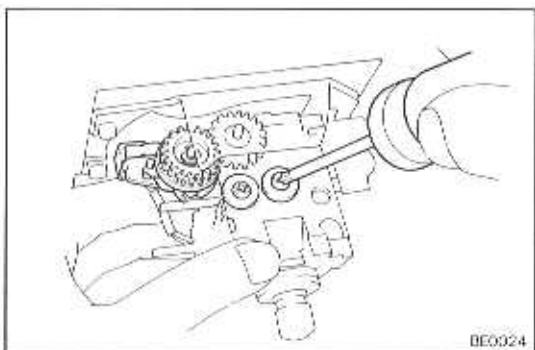

[LF, LH11, LX, LY]

- (a) Loosen the mount screws and disconnect the interval counter gear from the turn gear.

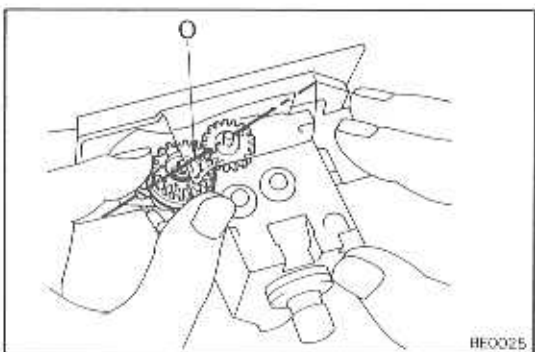

- (b) Align the 0 of the interval counter gear with the turn gear as shown.
- (c) Attach the interval counter gear to the turn gear and tighten the mount bolts.

3. INSTALL SPEEDOMETER

4. START ENGINE AND CHECK THAT WARNING LIGHT GOES OUT

If the timing belt warning light lights, turn off the warning light.

CAUTION: If replacing the speedometer but not the timing belt, set the new interval counter in the same position as the previous one.

SERVICE SPECIFICATIONS

	Page
ENGINE MECHANICAL	A-2
FUEL SYSTEM	A-6
COOLING SYSTEM	A-12
LUBRICATION SYSTEM	A-13
STARTING SYSTEM	A-13
CHARGING SYSTEM	A-14

ENGINE MECHANICAL

Specifications

Drive belt deflection with 10 kg or 22 lb					
Water pump - Alternator	New belt		7 - 10 mm		0.28 - 0.39 in.
	Used belt		10 - 14 mm		0.39 - 0.55 in.
Crankshaft - PS vane Pump	New belt		8 - 10 mm		0.31 - 0.39 in.
	Used belt		10 - 14 mm		0.39 - 0.55 in.
Crankshaft - A/C compressor	New Belt		13 - 17 mm		0.51 - 0.67 in.
	Used Belt		17 - 23 mm		0.67 - 0.91 in.
Engine oil capacity	Drain and refill				
	w/o Oil filter change		4.8 liters	5.1 USqt	4.2 Imp.qt
	w/ Oil filter change		5.8 liters	6.1 USqt	5.1 Imp.qt
	Dry fill		6.5 liters	6.9 USqt	5.7 Imp.qt
Valve clearance	at hot	IN	0.25 mm		0.0098 in.
		EX	0.36 mm		0.0142 in.
Injection timing					
Plunger stroke	at 0°TDC	L	0.94 - 1.06 mm		0.0370 - 0.0417 in.
		2L w/o ACSD	1.06 - 1.22 mm		0.0417 - 0.0480 in.
		w/ ACSD	0.82 - 0.98 mm		0.0323 - 0.0386 in.
		2L-T	0.75 - 0.87 mm		0.0295 - 0.0343 in.
Injection order			1 - 3 - 4 - 2		
Idle speed	M/T (ex. LX)		700 rpm		
	M/T (LX) & A/T		800 rpm		
Maximum speed	L, 2L (ex. LS Hong Kong & Singapore, Australia LY & LN56), 2L-T		4,900 rpm		
	2L (LS Hong Kong & Singapore, Australia LY & LN56)		4,500 rpm		
Compression pressure at 250 rpm	STD	L, 2L-T	30.0 kg/cm ²	427 psi	2,942 kPa
		2L	32.0 kg/cm ²	455 psi	3,138 kPa
	Limit		20.0 kg/cm ²	284 psi	1,961 kPa
Pressure difference between each cylinder			Less than 5.0 kg/cm ² (71 psi, 490 kPa)		
Timing belt tension spring	Free length		39.7 - 40.7 mm		1,563 - 1,602 in.
	Installed tension	at 52 mm (2.05 in.)	4.0 kg	8.8 lb	39 N
Cylinder head	Cylinder block surface warpage				
	Limit		0.2 mm		0.008 in.
	Intake manifold surface warpage				
	Limit		0.2 mm		0.008 in.
	Exhaust manifold surface warpage				
	Limit		0.2 mm		0.008 in.
Valve seat	Refacing angle		30°, 45°, 65°		
		Contacting angle	45°		
		Contacting width	1.2 - 1.6 mm		0.047 - 0.063 in.
Valve guide	Inner diameter		8.51 - 8.53 mm		0.3350 - 0.3358 in.
	Outer diameter	STD type	14.028 - 14.041 mm		0.5523 - 0.5528 in.
		O/S type 0.05	14.078 - 14.091 mm		0.5543 - 0.5548 in.

1988 (on) 7.4 DIESEL 84 - 96

Specifications (Cont'd)

Valve	Valve overall length	STD	IN	122.95 mm	4.8405 in.
			EX	122.75 mm	4.8327 in.
		Limit	IN	122.45 mm	4.8209 in.
			EX	122.25 mm	4.8130 in.
	Valve face angle			44.5°	
	Stem diameter		IN	8.473 – 8.489 mm	0.3336 – 0.3342 in.
			EX	8.454 – 8.470 mm	0.3328 – 0.3335 in.
	Stem clearance	STD	IN	0.021 – 0.057 mm	0.0008 – 0.0022 in.
			EX	0.040 – 0.076 mm	0.0016 – 0.0030 in.
		Limit	IN	0.10 mm	0.0039 in.
			EX	0.12 mm	0.0047 in.
Valve head margin thickness	Limit	IN	0.9 mm	0.035 in.	
		EX	1.0 mm	0.039 in.	
Valve spring	Free length		47.98 mm	1.8890 in.	
	Installed tension at 39.3 mm (1.547 in.)		29.2 kg 64.4 lb 286 N		
	Squareness	Limit	2.0 mm	0.079 in.	
Valve rocker arm and shaft	Rocker arm inside diameter	STD	18.500 – 18.521 mm	0.7283 – 0.7292 in.	
	Shaft diameter	STD	18.464 – 18.483 mm	0.7269 – 0.7277 in.	
	Arm to shaft oil clearance	STD	0.017 – 0.057 mm	0.0007 – 0.0022 in.	
		Limit	0.1 mm	0.004 in.	
Camshaft	Thrust clearance	STD	0.055 – 0.155 mm	0.0022 – 0.0061 in.	
		Limit	0.3 mm	0.012 in.	
	Journal oil clearance	STD	0.022 – 0.074 mm	0.0009 – 0.0029 in.	
		Limit	0.1 mm	0.004 in.	
	Journal diameter	STD	34.969 – 34.985 mm	1.3767 – 1.3774 in.	
			U/S 0.125	34.844 – 34.860 mm	1.3718 – 1.3724 in.
			U/S 0.250	34.719 – 34.735 mm	1.3669 – 1.3675 in.
	Circle runout	Limit	0.1 mm	0.039 in.	
	Cam lobe height	Limit	IN L, 2L	46.76 mm	1.8409 in.
			2L-T	46.29 mm	1.8224 in.
		EX	47.25 mm	1.8602 in.	
Combustion chamber	Protrusion		0.01 – 0.07 mm	0.0004 – 0.0028 in.	
	Combustion chamber shim thickness		0.05 mm	0.0020 in.	
			0.10 mm	0.0039 in.	
			0.15 mm	0.0059 in.	
			0.20 mm	0.0079 in.	

Specifications (Cont'd)

Cylinder block and cylinder	Warpage	Limit	0.2 mm	0.008 in.		
	Cylinder bore					
	STD sized piston	STD	L	90.000 – 90.030 mm	3.5433 – 3.5445 in.	
			2L, 2L-T	92.000 – 92.030 mm	3.6220 – 3.6232 in.	
		Limit	L	90.23 mm	3.5524 in.	
			2L, 2L-T	92.23 mm	3.6311 in.	
	O/S sized piston	STD	L	90.500 – 90.530 mm	3.5630 – 3.5642 in.	
			2L, 2L-T	92.500 – 92.530 mm	3.6417 – 3.6429 in.	
		Limit	L	90.73 mm	3.5720 in.	
			2L, 2L-T	92.73 mm	3.6508 in.	
Piston and piston ring	Piston diameter					
	STD sized piston	L	89.955 – 89.985 mm	3.5415 – 3.5427 in.		
			91.940 – 91.970 mm	3.6197 – 3.6209 in.		
	O/S sized piston	L	90.455 – 90.485 mm	3.5612 – 3.5624 in.		
			92.440 – 92.470 mm	3.6394 – 3.6405 in.		
	Piston to cylinder clearance	STD	L	0.035 – 0.055 mm	0.0014 – 0.0022 in.	
			2L, 2L-T	0.050 – 0.070 mm	0.0020 – 0.0028 in.	
			Limit	0.14 mm	0.0055 in.	
	Piston ring land to piston ring clearance	L	No. 1 ring	0.010 – 0.055 mm	0.0004 – 0.0022 in.	
			2L, 2L-T	0.020 – 0.065 mm	0.0008 – 0.0026 in.	
			No. 2 ring	0.040 – 0.100 mm	0.0016 – 0.0039 in.	
	Oil ring			0.030 – 0.070 mm	0.0012 – 0.0028 in.	
	Piston ring end gap	STD	L	No. 1 ring	0.30 – 0.57 mm	0.0118 – 0.0224 in.
				2L, 2L-T	0.35 – 0.62 mm	0.0138 – 0.0244 in.
		Maximum	L	No. 2 ring	1.30 mm	0.051 in.
				2L, 2L-T	0.20 – 0.52 mm	0.0079 – 0.0205 in.
		Maximum	L	No. 2 ring	0.20 – 0.47 mm	0.0079 – 0.0185 in.
				2L, 2L-T	1.12 mm	0.044 in.
	Oil ring (Side rail)	STD	Maximum	No. 2 ring	1.07 mm	0.042 in.
				Oil ring (Side rail)	0.20 – 0.52 mm	0.0079 – 0.0205 in.
				1.12 mm	0.044 in.	
	Piston pin installing temperature			60 – 70°C	140 – 158 °F	
Connecting rod	Thrust clearance	STD	Limit	0.08 – 0.20 mm	0.0031 – 0.0079 in.	
			Limit	0.3 mm	0.012 in.	
	Pin to bushing oil clearance	STD	Limit	0.004 – 0.012 mm	0.0002 – 0.0005 in.	
			Limit	0.05 mm	0.0020 in.	
	Rod bend [per 100 mm (3.94 in.)]	Limit	Limit	0.05 mm	0.0020 in.	
			Limit	0.15 mm	0.0059 in.	

Specifications (Cont'd)

Crankshaft	Thrust clearance	STD		0.04 – 0.25 mm	0.0016 – 0.0098 in.
		Limit		0.3 mm	0.012 in.
	Thrust washer thickness				
		STD size		2.430 – 2.480 mm	0.0957 – 0.0976 in.
		O/S 0.125		2.493 – 2.543 mm	0.0981 – 0.1001 in.
		O/S 0.250		2.555 – 2.605 mm	0.1006 – 0.1026 in.
	Main journal oil clearance				
		STD		0.034 – 0.065 mm	0.0013 – 0.0026 in.
		Limit		0.1 mm	0.004 in.
	Main journal diameter				
		STD		61.985 – 62.000 mm	2.4403 – 2.4409 in.
	Main journal finished diameter				
		U/S 0.25		61.735 – 61.750 mm	2.4305 – 2.4311 in.
		U/S 0.50		61.385 – 61.500 mm	2.4167 – 2.4213 in.
	Crank pin oil clearance				
		STD		0.036 – 0.064 mm	0.0014 – 0.0025 in.
		Limit		0.1 mm	0.004 in.
	Crank pin diameter	STD	L, 2L 2L-T	52.988 – 53.000 mm 54.988 – 55.000 mm	2.0861 – 2.0866 in. 2.1649 – 2.1654 in.
	Crank pin finished diameter				
		U/S 0.25	L, 2L 2L-T	52.738 – 52.750 mm 54.738 – 54.750 mm	2.0763 – 2.0768 in. 2.1550 – 2.1555 in.
	U/S 0.50	L, 2L 2L-T	52.488 – 52.500 mm 54.488 – 54.500 mm	2.0665 – 2.0669 in. 2.1452 – 2.1457 in.	
Circle runout	Limit		0.1 mm	0.039 in.	
Taper and out-of-round					
Main journal and crank pin	Limit		0.02 mm	0.0008 in.	

Torque Specifications

Part tightend		kg-cm	Ft-lb	N-m
No. 2 idler pulley x Oil pump body		400	29	39
Injection pump drive pulley x Drive shaft		650	47	64
Camshaft timing pulley x Camshaft		1,000	72	98
No. 1 idler pulley x Oil pump body		195	14	19
Glow plug x Cylinder head		130	9	13
Crankshaft pulley x Crankshaft		1,400	101	137
Camshaft bearing cap x Cylinder head		195	14	19
Valve rocker support x Cylinder head		195	14	19
Cylinder head x Cylinder block		1,200	87	118
Camshaft oil seal retainer x Cylinder head		185	13	18
Exhaust manifold x Cylinder head	L, 2L 2L-T	400 530	29 38	39 52
Exhaust manifold x Insulator		120	9	12
Water outlet housing x Cylinder head		195	14	19
Intake manifold x Cylinder head		240	17	24
RH engine hanger x Cylinder head		380	27	37
Connecting rod cap x Connecting rod		600	43	59
Main bearing cap x Cylinder block		1,050	76	103
Oil Check Valve x Cylinder block		260	19	25

Tightening Torque (Cont'd)

Tightening part		kg-cm	ft-lb	N·m
Rear oil seal retainer x Cylinder block		130	9	13
Rear end plate x Cylinder block		120	9	12
Water pump x Oil pump body		195	14	19
Water outlet x Water outlet housing		195	14	19
Oil pump body x Cylinder block		195	14	19
Oil pump body x Injection pump		210	15	21
Oil pan x Cylinder block	Bolt	80	69 in.-lb	8
	Nut	175	13	17
Oil cooler x Oil filter bracket		145	10	14
Oil filter bracket x Cylinder block	Bolt	195	14	19
	Nut	210	15	21
Relief valve plug x Oil filter bracket		370	27	36
Oil pan drain plug		400	29	39
Injection nozzle x Cylinder head		700	51	69
Nozzle leakage pipe x Injection nozzle		500	37	49
Injection pipe x Injection nozzle and pump		250	18	25
Fuel outlet pipe x Injection pump		230	17	23
Fuel inlet pipe x Injection pump		230	17	23

FUEL SYSTEM

Fuel heater	Resistance at 20°C (68°F)	Approx. 0.73 ± 0.29 Ω
Injection nozzle	Nozzle type (Stamped on nozzle assembly)	
	L	ND-DN4SDND90
	2L, 2L-T (ex. LS Hong Kong & Singapore)	ND-DN4SDND133
	2L (LS Hong Kong & Singapore)	ND-DN4SDND139
	Nozzle opening pressure	
	Inspection	
	Reused nozzle	
	L, 2L (ex. LS Hong Kong & Singapore), 2L-T	105 – 125 kg/cm ² (1,493 – 1,778 psi, 10,297 – 12,258 kPa)
	2L (LS Hong Kong & Singapore)	145 – 168 kg/cm ² (2,062 – 2,389 psi, 14,220 – 16,475 kPa)
	New nozzle	
	L, 2L (ex. LS Hong Kong & Singapore), 2L-T	115 – 125 kg/cm ² (1,636 – 1,778 psi, 11,278 – 12,258 kPa)
	2L (LS Hong Kong & Singapore)	160 – 168 kg/cm ² (2,276 – 2,389 psi, 15,691 – 16,475 kPa)
	Adjustment	
	L, 2L (ex. LS Hong Kong & Singapore), 2L-T	110 – 125 kg/cm ² (1,565 – 1,778 psi, 10,787 – 12,258 kPa)
	2L (LS Hong Kong & Singapore)	160 – 168 kg/cm ² (2,276 – 2,389 psi, 15,691 – 16,475 kPa)

FUEL SYSTEM (Cont'd)

Injection nozzle (Cont'd)	Adjusting shim thickness		0.70 mm	0.0276 in.
			0.75 mm	0.0295 in.
			0.80 mm	0.0315 in.
			0.85 mm	0.0335 in.
			0.90 mm	0.0354 in.
			0.95 mm	0.0374 in.
			1.00 mm	0.0394 in.
			1.05 mm	0.0413 in.
			1.10 mm	0.0433 in.
			1.15 mm	0.0453 in.
			1.20 mm	0.0472 in.
			1.25 mm	0.0492 in.
			1.30 mm	0.0512 in.
			1.35 mm	0.0531 in.
			1.40 mm	0.0551 in.
			1.45 mm	0.0571 in.
			1.50 mm	0.0591 in.
			1.55 mm	0.0610 in.
			1.60 mm	0.0630 in.
			1.65 mm	0.0650 in.
1.70 mm	0.0669 in.			
1.75 mm	0.0689 in.			
1.80 mm	0.0709 in.			
1.85 mm	0.0728 in.			
1.90 mm	0.0748 in.			
1.95 mm	0.0768 in.			
Injection pump	Direction of rotation		Clockwise as seen from drive side	
	Cam lift of face camplate	L, 2L-T 2L	2.2 mm	0.315 in.
			2.5 mm	0.098 in.
	Injection order		1-3-4-2 (A-B-C-D)	
	Adjusting lever moving angle			
	L		30 - 36°	
	2L A/T & LX70		41 - 51°	
	2L M/T & LX71 (ex. LS Hong Kong & Singapore)		43 - 49°	
	LS Hong Kong & Singapore		40 - 46°	
	Roller height variation		0.02 mm	0.0008 in.
	Plunger spring squareness Limit		2.0 mm	0.079 in.
	Pickup sensor resistance		600 - 800 Ω	
	Governor shaft protrusion		1.0 - 2.0 mm	0.039 - 0.079 in.
	Flyweight holder thrust clearance		0.15 - 0.35 mm	0.0059 - 0.0138 in.
	Plunger spring shim thickness		0.5 mm	0.020 in.
		0.8 mm	0.031 in.	
		1.0 mm	0.039 in.	
		1.2 mm	0.047 in.	
		1.5 mm	0.057 in.	
		1.8 mm	0.071 in.	
		2.0 mm	0.079 in.	
Plunger adjusting shim thickness		1.9 mm	0.075 in.	
		2.0 mm	0.079 in.	
		2.1 mm	0.083 in.	
		2.2 mm	0.087 in.	
		2.3 mm	0.091 in.	

FUEL SYSTEM (Cont'd)

Injection pump (Cont'd)	Plunger adjusting shim thickness (Cont'd)	2.4 mm	0.094 in.
		2.5 mm	0.098 in.
		2.6 mm	0.102 in.
		2.7 mm	0.106 in.
		2.8 mm	0.110 in.
		2.9 mm	0.114 in.
	Governor gear adjusting washer thickness	1.05 mm	0.0413 in.
		1.25 mm	0.0492 in.
		1.45 mm	0.0571 in.
		1.65 mm	0.0650 in.
		1.85 mm	0.0728 in.
	Governor sleeve plug head thickness	3.3 mm	0.130 in.
		3.4 mm	0.134 in.
		3.5 mm	0.138 in.
3.6 mm		0.142 in.	
3.7 mm		0.146 in.	
3.8 mm		0.150 in.	
3.9 mm		0.154 in.	
4.0 mm		0.157 in.	
Injection pipe	Overall length	477 – 483 mm	18.8 – 19.0 in.
	Outside diameter	6 mm	0.2 in.
	Inside diameter	2.2 mm	0.09 in.

Injection Pump Adjustment and Test

Preparations of pump tester	Test nozzle type	DN12SD12			
	Test nozzle opening pressure	145 – 155 kg/cm ² (2,062 – 2,205 psi, 14,220 – 15,200 kPa)			
	Injection pipe	Outer diameter	6.0 mm	0.236 in.	
		Inner diameter	2.0 mm	0.079 in.	
		Length	840 mm	33.07 in.	
		Minimum bending radius	More than 25 mm (0.98 in.)		
	Fuel temperature	40 – 45°C	104 – 113°F		
Fuel feeding pressure	0.2 kg/cm ²	2.8 psi	20 kPa		
Fuel cut solenoid voltage	6V				
Pump inner pressure	Item	Pump rpm	Inner pressure kg/cm ² (psi,kPa)		
	2L LS Hong Kong & Singapore	400	2.2 – 2.8 (31 – 40, 216 – 275)		
		1,850	5.8 – 6.4 (82 – 91, 569 – 628)		
	LN56 & LY Australia	400	2.2 – 2.8 (31 – 40, 216 – 275)		
		2,000	6.2 – 6.8 (88 – 97, 608 – 667)		
	Others	400	2.2 – 2.8 (31 – 40, 216 – 275)		
2,200		6.7 – 7.3 (95 – 104, 657 – 716)			

Injection Pump Adjustment and Test (Cont'd)

Overflow volume	Item		Pump rpm	Overflow volume cc/min (cu. in./min.)		
	2L	LS Hong Kong & Singapore		1,850	330 - 750	(20.1 - 45.8)
		LY & LN56 Australia	2,000	350 - 770	(21.4 - 47.0)	
	Others		2,200	370 - 800	(22.6 - 48.8)	
Automatic timer	Item		Pump rpm	Piston stroke mm (in.)		
	L			800	0.8 - 1.6	(0.031 - 0.063)
			1,200	2.4 - 3.2	(0.094 - 0.126)	
			2,000	5.6 - 6.4	(0.220 - 0.252)	
			2,300	6.36 - 7.16	(0.2504 - 0.2819)	
	LX		800	2.0 - 2.8	(0.079 - 0.110)	
			1,200	3.6 - 4.4	(0.142 - 0.173)	
			2,000	6.8 - 7.6	(0.268 - 0.299)	
			2,300	7.6 - 8.4	(0.299 - 0.331)	
	2L	LS Hong Kong & Singapore	800	0.8 - 1.6	(0.031 - 0.063)	
				1,200	2.4 - 3.2	(0.094 - 0.126)
				1,750	4.55 - 5.35	(0.1791 - 0.2106)
	2L	LN56 & LY Australia	800	0.8 - 1.6	(0.031 - 0.063)	
				1,200	2.4 - 3.2	(0.094 - 0.126)
				1,900	5.2 - 6.0	(0.205 - 0.236)
	2L	Others	800	0.8 - 1.6	(0.031 - 0.063)	
				1,200	2.4 - 3.2	(0.094 - 0.126)
				2,000	5.6 - 6.4	(0.220 - 0.252)
				2,300	6.36 - 7.16	(0.2504 - 0.2819)
	2L-T		800	1.9 - 2.7	(0.075 - 0.106)	
			1,200	3.3 - 4.1	(0.130 - 0.161)	
			2,000	6.1 - 6.9	(0.240 - 0.272)	
			2,300	6.76 - 7.58	(0.2661 - 0.2984)	
Full-load injection volume	Item		Adjusting lever angle	Pump rpm	No. of measuring strokes	Injection volume cc (cu in.)
	L		Plus 9.0 - 19.0°	1,200	200	7.54 - 7.86 (0.46 - 0.48)
	2L	ex. LS Hong Kong & Singapore	Plus 23.5 - 33.5°	1,200	200	9.34 - 9.66 (0.57 - 0.59)
		LS Hong Kong & Singapore	Plus 20.5 - 30.5°	1,200	200	9.24 - 9.56 (0.56 - 0.58)
	2L-T		Plus 23.5 - 33.5°	1,200	200	10.4 - 13.60 (0.63 - 0.83)

Injection Pump Adjustment and Test (Cont'd)

Maximum speed	Item		Adjusting lever angle		Pump rpm	No. of measuring stroke	Injection volume cc (cu. in.)		Remarks				
	Injection volume	L		Plus	9.0 – 19.0°	2,450	200	3.9 – 4.5 (0.24 – 0.27)		Adjust			
2,250						200	5.7 – 6.9 (0.35 – 0.42)		Check				
2,700						200	Less than 1.3 (0.08)		Check				
2L						ex. LS Hong Kong & Singapore	Plus	23.5 – 33.5°	2,450	200	3.8 – 5.4 (0.23 – 0.33)		Adjust
									2,250	200	6.8 – 8.0 (0.41 – 0.49)		Check
		2,700	200	Less than 1.3 (0.08)					Check				
2L		LS Hong Kong & Singapore	Plus	20.5 – 30.5°	2,250	200	3.8 – 5.4 (0.23 – 0.33)		Adjust				
					2,000	200	7.4 – 8.6 (0.45 – 0.52)		Check				
					2,500	200	Less than 1.3 (0.08)		Check				
2L-T *			Plus	23.5 – 33.5°	2,450	200	3.2 – 5.2 (0.20 – 0.32)		Adjust				
					2,250	200	6.7 – 8.5 (0.41 – 0.52)		Check				
					2,700	200	Less than 1.3 (0.08)		Check				
Injection volume		L		Plus	9.0 – 19.0°	1,200	200	7.54 – 7.86 (0.46 – 0.48)		0.4 (0.02)	Basic full-load injection volume		
						100	200	8.2 – 12.0 (0.50 – 0.73)		0.8 (0.05)	Volume during starting		
						350	200	7.0 – 9.6 (0.43 – 0.59)		0.5 (0.03)	–		
	500					200	6.3 – 7.3 (0.38 – 0.45)		0.5 (0.03)	–			
	2,100					200	6.5 – 7.4 (0.40 – 0.45)		0.5 (0.03)	–			
	2L	LN56 & LY Australia	Plus	23.5 – 33.5°	1,200	200	9.34 – 9.66 (0.57 – 0.59)		0.4 (0.02)	Basic full-load injection volume			
					100	200	8.6 – 12.4 (0.52 – 0.76)		0.8 (0.05)	Volume during starting			
					500	200	7.2 – 8.2 (0.44 – 0.50)		0.5 (0.03)	–			
					2,000	200	7.8 – 8.7 (0.48 – 0.53)		0.5 (0.03)	–			

* Apply 0.48 kg/cm² (6.8 psi, 47 kPa) Pressure

Injection Pump Adjustment and Test (Cont'd)

Injection volume (cont'd)	Item		Adjusting lever angle	Pump rpm	No. of measuring strokes	Injection volume cc (cu. in.)	Variation limit cc (cu. in.)	Remarks
2L	LS Hong Kong & Singapore	Plus 20.5 – 30.5°	1,200	200	9.24 – 9.56 (0.56 – 0.58)	0.4 (0.02)	Basic full-load injection volume	
			100	200	6.6 – 10.4 (0.40 – 0.63)	0.8 (0.05)	Volume during starting	
			500	200	7.6 – 8.6 (0.46 – 0.52)	0.5 (0.03)	—	
			1,850	200	8.1 – 9.0 (0.49 – 0.55)	0.5 (0.03)	—	
	M/T, ex. LS Hong Kong, Singapore & Australia (LN 56 & LY)	Plus 23.5 – 33.5°	1,200	200	9.34 – 9.66 (0.57 – 0.59)	0.4 (0.02)	Basic full-load injection volume	
			100	200	8.6 – 12.4 (0.52 – 0.76)	0.8 (0.05)	Volume during starting	
			500	200	7.2 – 8.2 (0.44 – 0.50)	0.5 (0.03)	—	
			2,100	200	7.6 – 8.5 (0.46 – 0.52)	0.5 (0.03)	—	
			350	200	7.7 – 10.3 (0.47 – 0.63)	0.5 (0.03)	—	
	A/T & LX, ex. LS Hong Kong & Singapore	Plus 23.5 – 33.5°	1,200	200	9.34 – 9.66 (0.57 – 0.59)	0.4 (0.02)	Basic full-load injection volume	
			100	200	8.6 – 12.4 (0.52 – 0.76)	0.8 (0.05)	Volume during starting	
			500	200	7.2 – 8.2 (0.44 – 0.50)	0.5 (0.03)	—	
			2,100	200	7.6 – 8.5 (0.46 – 0.52)	0.5 (0.03)	—	
	2L-T	Plus 23.5 – 33.5°	* ₁ 1,200	200	10.04 – 10.36 (0.61 – 0.63)	0.4 (0.02)	Basic full-load injection volume	
			100	200	10.2 – 13.6 (0.62 – 0.83)	0.8 (0.05)	Volume during Starting	
			* ₂ 500	200	7.3 – 8.1 (0.45 – 0.49)	0.5 (0.03)	—	
* ₁ 2,100			200	10.0 – 11.2 (0.61 – 0.68)	0.5 (0.03)	—		
Full-load minimum injection volume (2L-T only)	Pump rpm	No. of measuring strokes		Injection volume cc (cu.in.)				
	1,200	200		7.9 – 8.7 (0.48 – 0.53)				
Boost compensator characteristic (2L-T only)	Pump rpm	No. of measuring strokes		Injection volume cc (cu.in.)				
	1,200	200		8.3 – 9.1 (0.51 – 0.56)				
Boost compensator characteristic tendency (2L-T only)	Pump rpm	Pressure kg/cm ² (psi, KPa)	No. of measuring strokes	Injection volume cc (cu.in.)		Hysteresis cc (cu.in.)		
	1,200	0.88 (12.5, 86)	200	7.6 – 9.0 (0.46 – 0.55)		—		
	1,200	0.61 (8.7, 60)	200	9.9 – 10.5 (0.60 – 0.64)		Less than 0.6 (0.04)		
	1,200	0.34 (4.8, 33)	200	9.6 – 10.2 (0.59 – 0.62)		—		
	1,200	0.14 (2.0, 14)	200	8.3 – 9.1 (0.51 – 0.56)		Less than 0.3 (0.02)		
1,200	0 (0, 0)	200	7.9 – 8.7 (0.48 – 0.53)		—			

*₁ Apply 0.48 kg/cm² (6.8 psi, 47 kpa) Pressure

*₂ Apply 0.04 kg/cm² (0.57 psi, 3.9 kpa) pressure

Injection Pump Adjustment and Test (Cont'd)

Load sensing timer	Item		Pump rpm	No. of measuring strokes	Injection volume cc (cu. in.)		Remarks		
	L		1,200	200	Full injection volume minus 1.4 (0.09) ± 0.4 (0.02)		Set to starting point		
2L		1,200	200						
2L-T		1,750	200						
L		1,200	200	2.6 – 3.0	(0.16 – 0.18)	Check ending point			
2L		1,200	200	6.2 – 6.6	(0.38 – 0.40)				
2L-T		1,750	200	7.3 – 7.7	(0.45 – 0.47)				
Item		Pump rpm		Timer piston fluctuation mm (in.)		Remarks			
L	w/o HAC	1,200		1.2 – 1.6	(0.047 – 0.063)	Check			
2L	w/ HAC	1,200		0.8 – 1.2	(0.031 – 0.047)				
2L-T		1,750		1.2 – 1.6	(0.047 – 0.063)				
Idle speed	Item		Adjusting lever angle	Pump rpm	No. of measuring strokes	Injection volume cc (cu. in.)	Variation limit cc (cu. in.)	Remarks	
	L		Minus 14.0 – 24.0°	350	200	1.1 – 2.1 (0.07 – 0.13)	–	Adjust	
				525	200	Less than 0.3 (0.02)	–	Check	
	2L	M/T, ex. LX	Minus 12.5 – 22.5°	350	200	1.3 – 2.3 (0.08 – 0.14)	0.34 (0.021)	Adjust	
				525	200	Less than 0.3 (0.02)	–	Check	
		A/T & LX		Minus 13.5 – 21.5°	400	200	A=1.3 – 2.3 (0.08 – 0.14)	0.34 (0.021)	Adjust
					375	200	A add 0.36 (0.022)	–	Check
				475	200	A subtract 0.7 – 1.7 (0.04 – 0.10)	–	Check	
	2L-T		Minus 13.5 – 21.5°	400	200	A=1.4 – 2.4 (0.09 – 0.15)	0.34 (0.021)	Adjust	
				375	200	A add 0.36 (0.02)	–	Check	
				525	200	A subtract 0.7 – 1.7 (0.04 – 0.10)	–	Check	
				650	200	Less than 0.4 (0.02)	–	Check	

COOLING SYSTEM

Coolant capacity (w/ Heater)	LF, LH, LN	10.6 liters	11.2 US qt	9.3 imp. qt
	LS	8.8 liters	9.3 US qt	7.7 imp. qt
	LX	9.0 liters	9.5 US qt	8.0 imp. qt
	LY	9.7 liters	10.3 US qt	8.5 imp. qt
Thermostat	Valve opening temperature	86 – 90°C 187 – 194°F		
	Valve lift at 100°C (212°F)	More than 8 mm (0.31 in.)		
Radiator	Relief valve opening pressure	STD	0.75 – 1.05 kg/cm ² (10.7 – 14.9 psi, 74 – 103 kPa)	
	Limit		0.6 kg/cm ² 8.5 psi 59 kPa	

LUBRICATION SYSTEM

Oil Pressure		at idle at 3000 rpm	More than 0.3 kg/cm ² (4.3 psi, 29 kPa) 2.5 – 6.0 kg/cm ² (36 – 85 psi, 245 – 588 kPa)
Oil pump	Body clearance	STD	0.06 – 0.15 mm 0.0024 – 0.0059 in.
		Limit	0.20 mm 0.0079 in.
	Tip clearance	STD	0.15 – 0.21 mm 0.0059 – 0.0083 in.
		Limit	0.30 mm 0.0118 in.
	Side clearance	STD	0.03 – 0.09 mm 0.0012 – 0.0035 in.
		Limit	0.15 mm 0.0059 in.

STARTING SYSTEM

Pre-heating system	Light lighting time			
	Super glow type			
	at 20°C (68°F)	L, 2L 2L-T	Approx. 2 seconds Approx. 1.5 seconds	
	Variable delay type			
at 20°C (68°F)		9 – 15 seconds		
Fixed delay type				
at minus 25 – 60°C (minus 13 – 140°F)		20.0 – 20.5 seconds		
Starter	Rated voltage and output power		12V 2.0 kW 12V 2.5kW	
	No-load characteristic	Ampere	Less than 120A at 11.5V Less than 180A at 11.0V	
		rpm	More than 4,000 rpm More than 3,500 rpm	
	Brush length	STD	15.0 – 15.5 mm (0.591 – 0.610 in.)	20.5 – 21.0 mm (0.807 – 0.827 in.)
		Limit	9.5 mm 0.374 in.	13.0 mm 0.512 in.
	Spring installed load		2.7 – 3.3 kg (6.0 – 7.3 lb,	3.2 – 4.0 kg (7.1 – 8.8 lb,
			26 – 32 N)	31 – 39 N)
	Commutator	Diameter	STD	35 mm 1.38 in.
			Limit	34 mm 1.34 in.
	Undercut depth	STD	0.7 – 0.9 mm (0.028 – 0.035 in.)	0.7 – 0.9 mm (0.028 – 0.035 in.)
		Limit	0.2 mm 0.008 in.	0.2 mm 0.008 in.
	Circle runout	Limit	0.05 mm 0.0020 in.	0.05 mm 0.0020 in.

CHARGING SYSTEM

Battery specific gravity when fully charged at 20°C (68°F)			
		ex. NX110, 120, 200, 125D38L	1.25 – 1.27
		NX 110, 120, 200, 125D38L	1.27 – 1.29
Alternator	Rated output		12V40A, 12V45A, 12V50A, 12V55A, 12V60A
	Rotor coil resistance	w/o IC regulator	Approx. 4.0 Ω
		w/ IC regulator	Approx. 2.9 Ω
	Brush length	STD	20 mm
Limit		5.5 mm	0.217 in.
Alternator regulator	Regulator voltage	w/o IC regulator	13.8 – 14.8 V
		w/ IC regulator	13.8 – 14.4 V

TOYOTA L, 2L ENGINE REPAIR MANUAL FOR 2L-T ENGINE DESTINATIONS

NOTE: The following sections contain only the points which differ from the previous sections of this manual.

ENGINE MECHANICAL

EM

FUEL SYSTEM

FU

SERVICE SPECIFICATION (For 2L-T Engine)

A

ENGINE MECHANICAL

	Page
TURBOCHARGER DIAGNOSIS	EM-2
TURBOCHARGER ELECTRICAL SYSTEM DIAGNOSIS	EM-4
TURBOCHARGER	EM-5

TURBOCHARGER DIAGNOSIS

INSUFFICIENT ACCELERATION, LACK OF POWER OR EXCESSIVE FUEL CONSUMPTION

NOTE: Before troubleshooting the turbocharger, first check the valve clearance, injection timing, etc.

(Possible Cause)	(Check Procedure and Correction Method)
1. INSUFFICIENT TURBOCHARGING PRESSURE	Check turbocharging pressure (See page EM-6). If not within the standard shown below, begin diagnosis from item 2. Standard pressure: 0.41 – 0.54 kg/cm ² (5.8 – 7.7 psi, 40 – 53 kPa)
2. RESTRICTED INTAKE AIR SYSTEM	Check intake air system, and repair or replace parts as necessary. (See page EM-6)
3. LEAK IN INTAKE AIR SYSTEM	Check intake air system, and repair or replace parts as necessary. (See page EM-6)
4. RESTRICTED EXHAUST SYSTEM	Check exhaust system, and repair or replace parts as necessary, (See page EM-6)
5. LEAK IN EXHAUST SYSTEM	Check exhaust system, and repair or replace parts as necessary. (See page EM-6)
6. ERRATIC TURBOCHARGER OPERATION	Check rotation of impeller wheel. If it does not turn or turns with heavy drag, replace the turbocharger assembly. Check axial play of bearing shaft. If not within limits, replace the turbocharger assembly. Standard clearance: 0.13 mm (0.0051 in.) or less

ABNORMAL NOISE

(Possible Cause)

(Check Procedure and Correction Method)

1. TURBO INSULATOR RESONANCE

Check for loose, improperly installed or deformed insulator mount bolts, and repair or replace as necessary.

2. EXHAUST PIPE LEAKING OR VIBRATING

Check of deformed exhaust pipe, loose mount bolts or damaged gasket, and repair or replace as necessary.

3. ERRATIC TURBOCHARGER OPERATION

Refer to item 6 of insufficient acceleration, lack of power or excessive fuel consumption.

EXCESSIVE OIL CONSUMPTION OR WHITE EXHAUST

(Possible Cause)

(Check Procedure and Correction Method)

FAULTY TURBOCHARGER SEAL

Check for oil leakage in exhaust system.

- Remove the turbine elbow from the turbocharger and check for excessive carbon deposits on the turbine wheel. Excessive carbon deposits would indicate a faulty turbocharger.

Check for oil leakage in intake air system.

- Check for axial play in impeller wheel, and replace the turbocharger if necessary.
(See page EM-10).

CAUTION: There is some oil mist from the PCV in the blow by gas, so care must be taken not to diagnosis this as an oil leakage from the turbocharger.

TURBOCHARGER ELECTRICAL SYSTEM DIAGNOSIS

Troubleshooting of Turbocharger Indicator Light and Warning Light Operation

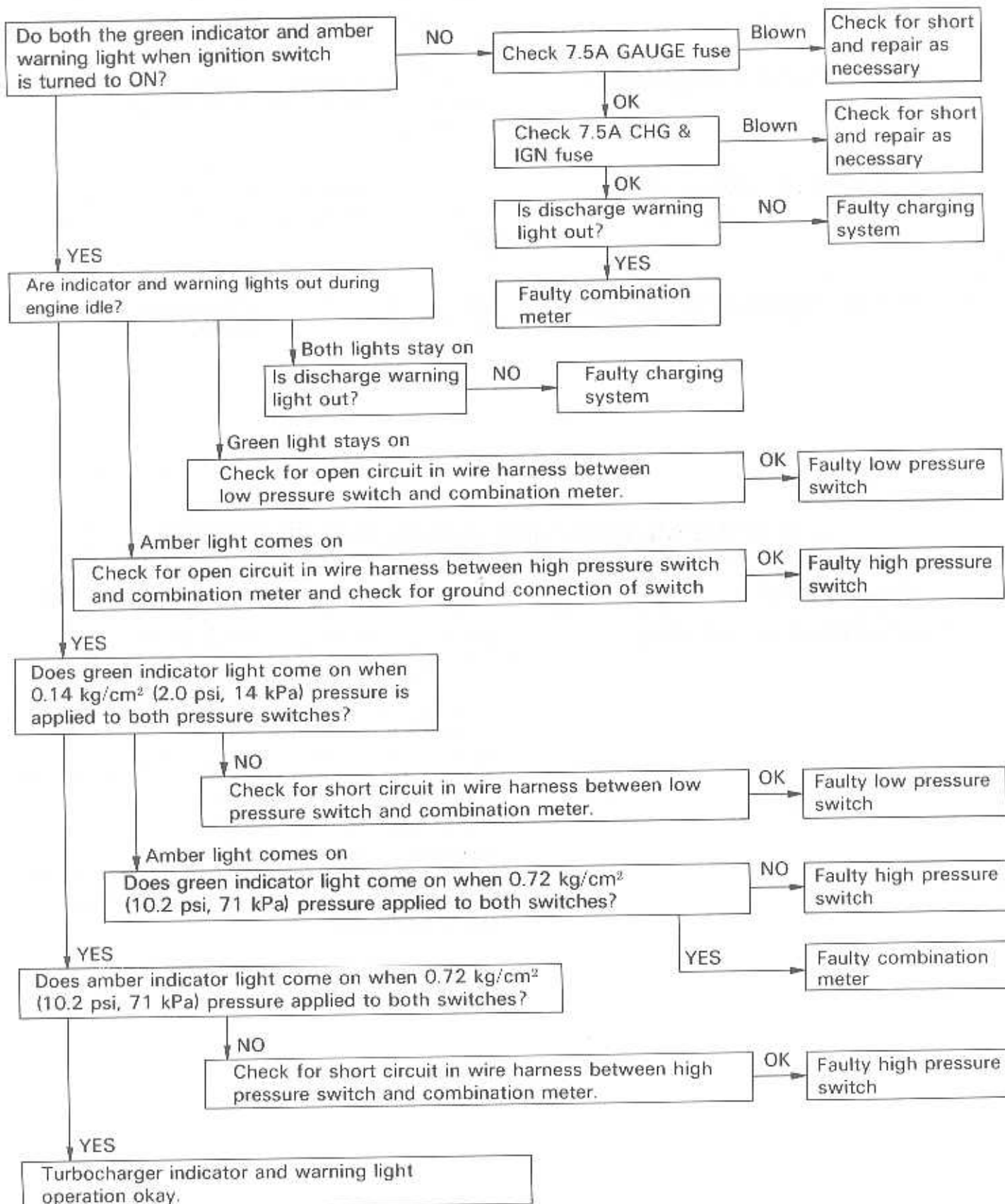

TURBOCHARGER

CAUTION:

- Do not stop the engine immediately after high-speed or uphill driving or pulling trailers. Keep the engine running at idle for 20 – 120 seconds depending on the driving condition.
- Avoid sudden racing or acceleration immediately after starting a cold engine.
- If the turbocharger is defective and must be replaced, first check for the cause of the defect in reference to the following items and replace parts if necessary:

Engine oil level and quality

Conditions under which the turbocharger was used

Oil lines leading to the turbocharger

- Use caution when removing and reinstalling the turbocharger assembly. Do not drop it or bang it against anything, and never grasp it by easily-deformed parts such as the actuator or rod when moving it.
- Before removing the turbocharger, plug the intake and exhaust ports and oil inlet to prevent entry of dirt or other foreign material.
- If replacing the turbocharger, check for accumulation of sludge particles in the oil pipes and, if necessary, replace the oil pipes.
- Completely remove the gaskets adhered to the lubrication oil pipe flange and turbocharger oil flange.
- If replacing bolts or nuts, do so only with the specified new ones to guard against breakage or deformation.
- If replacing the turbocharger, put in 20 cc (1.2 cu in.) of oil in the oil inlet of the new one and turn the impeller by hand to spread oil to the bearing.

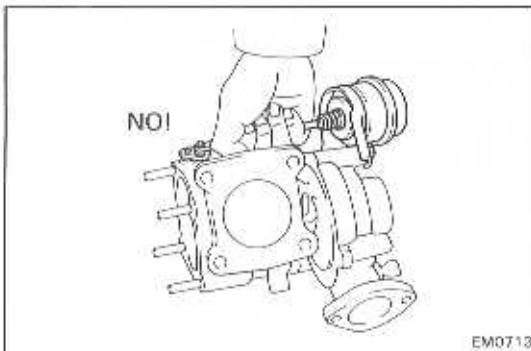

EM0713

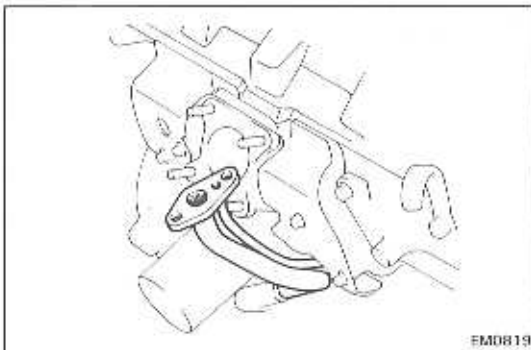

EM0819

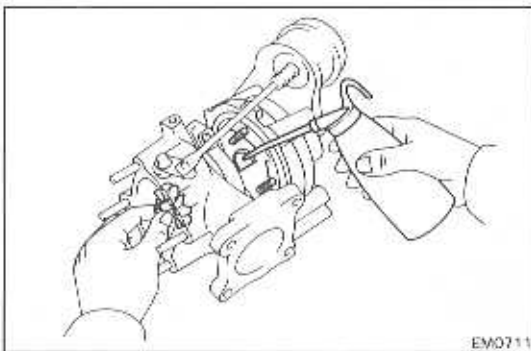

EM0711

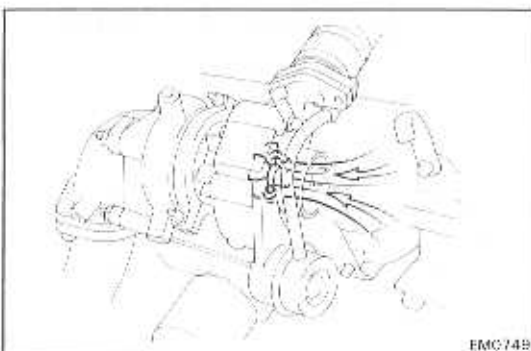

EMC74B

- If the engine is run with the air cleaner, case cover and hose removed, foreign material entering will damage the wheels which run at extremely high speed.
- If the engine was replaced or overhauled, shut off fuel and glow function after reassembly and crank the engine for 30 seconds to spread oil throughout. Then, allow the engine to idle for 60 seconds.

ON-VEHICLE INSPECTION OF TURBOCHARGER

1. INSPECT INTAKE AIR SYSTEM

Check for leakage or clogging between the air cleaner and turbocharger inlet and between the turbocharger outlet and cylinder head.

- Clogged air cleaner Clean or replace the element
- Hoses collapsed or deformed Repair and replace
- Leakage from connections Check each connection and repair
- Cracks in components Check and replace

2. INSPECT EXHAUST SYSTEM

Check for leakage or clogging between the cylinder head and turbocharger inlet and between the turbocharger outlet and exhaust pipe.

- Deformed components Repair or replace
- Foreign material in passages Remove
- Leakage from components Repair or replace
- Cracks in components Check and replace

3. INSPECT OPERATION OF ACTUATOR AND WASTE GATE VALVE

- (a) Disconnect the actuator hose.
- (b) Using a turbocharger pressure gauge (SST), apply about 0.58 kg/cm² (8.2 psi, 57 kPa) of pressure to the actuator hose and check that the rod moves 0.25 mm (0.0098 in.) or more.

If less, replace the turbocharger assembly.

SST 09992-00240

CAUTION: Never apply more than 0.7 kg/cm² (10.0 psi, 69 kPa) of pressure to the actuator.

4. CHECK TURBOCHARGING PRESSURE

- (a) Connect a 3-way union to the boost compensator pressure hose and install a turbocharger pressure gauge (SST) to it.

SST 09992-00240

- (b) While driving with the engine running at 2,400 rpm or more (throttle valve fully open in first gear), check the turbocharging pressure.

Standard pressure: 0.41 – 0.54 kg/cm²
(5.8 – 7.7 psi, 40 – 53 kPa)

If the pressure is less than that specified, first check the intake air and exhaust systems and the relief valve for leakage. If there is no leakage, replace the turbocharger assembly.

If the pressure is above specification, first check if the actuator hose is disconnected or cracked. If not, replace the turbocharger assembly.

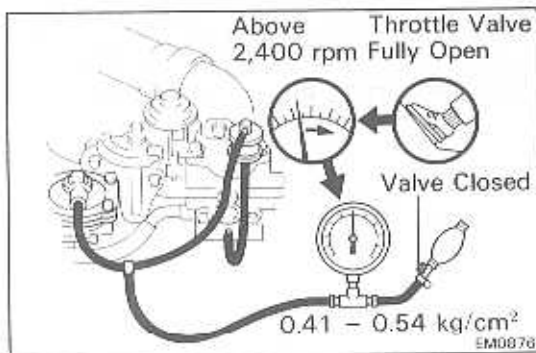
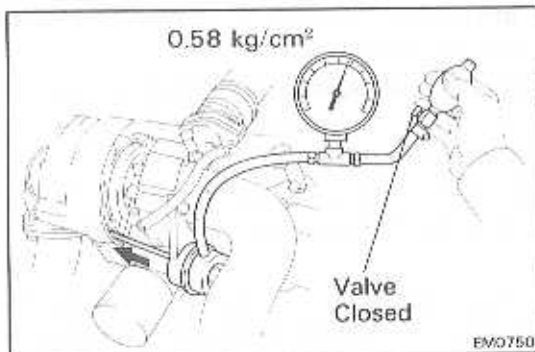

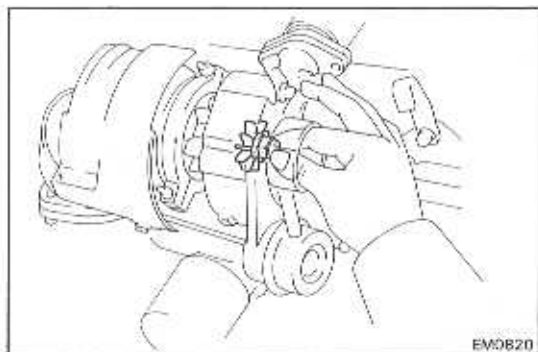
**5. INSPECT IMPELLER WHEEL ROTATION**

- (a) Disconnect the air cleaner hose.
- (b) Grasp the edge of the impeller wheel and turn it. Check that it turns smoothly.

If it does not turn or if it turns with drag, replace the turbocharger assembly.

COMPONENTS

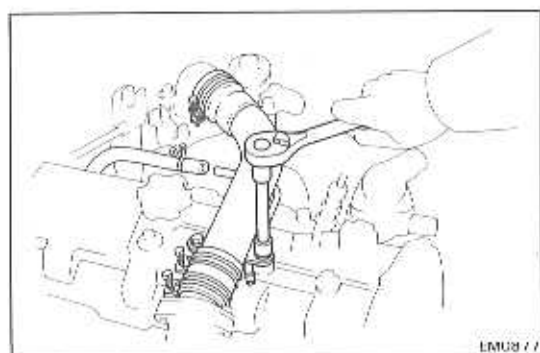
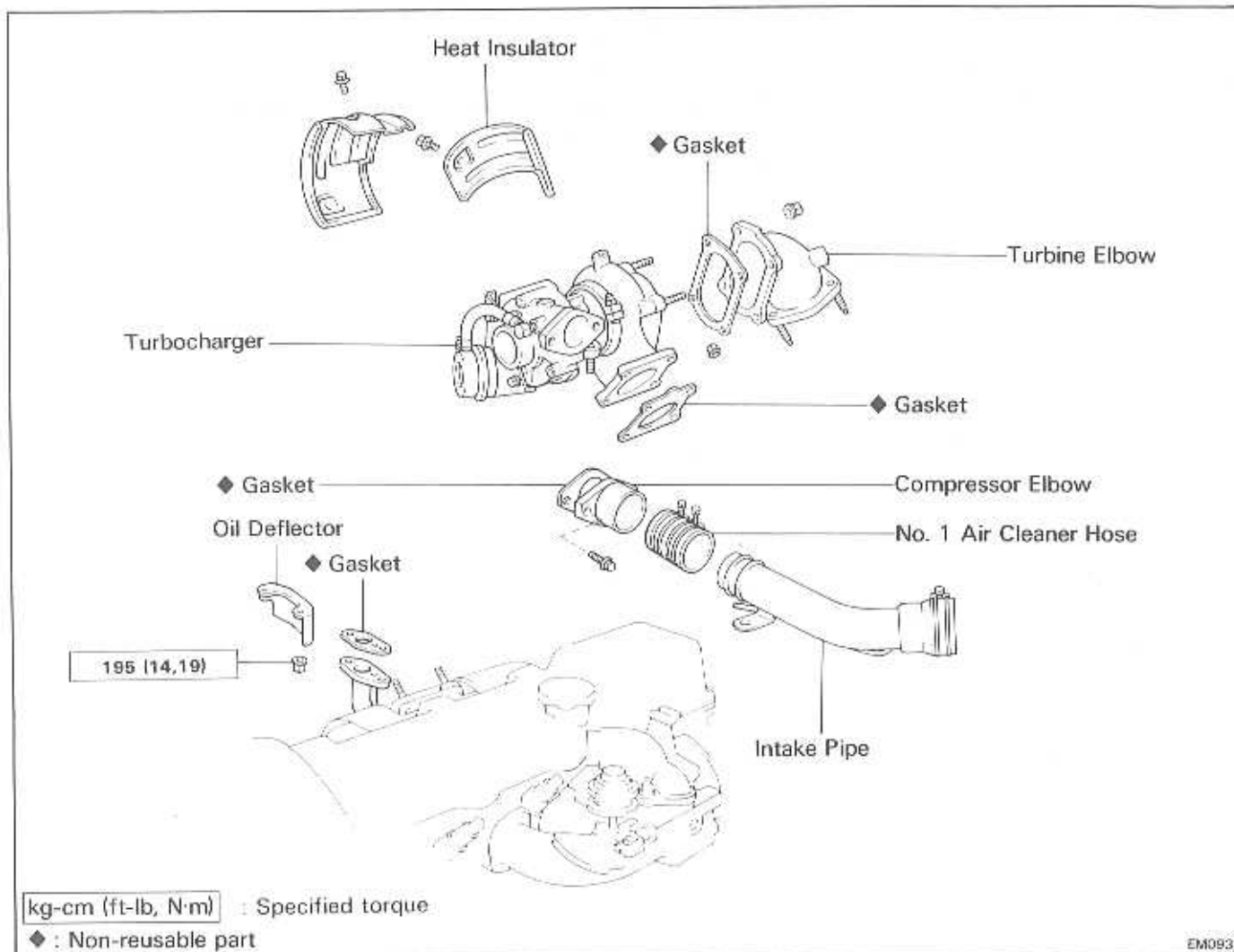

REMOVAL OF TURBOCHARGER

1. DISCONNECT ACCELERATOR CABLE

2. REMOVE AIR INTAKE PIPE

- Disconnect the PCV hoses from the air intake pipe.
- Loosen the three clamps.
- Remove the two bolts and air intake pipe.
- Remove the No.1 air cleaner hose.

3. REMOVE COMPRESSOR ELBOW

Remove the two bolts and disconnect the compressor elbow and gasket.

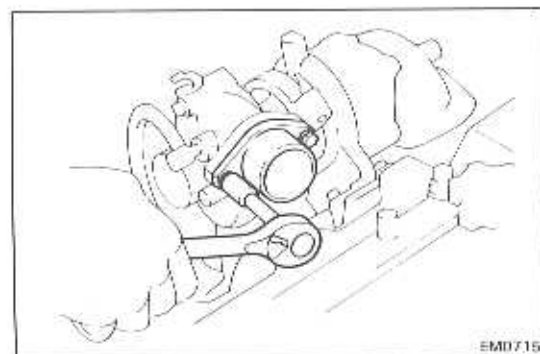

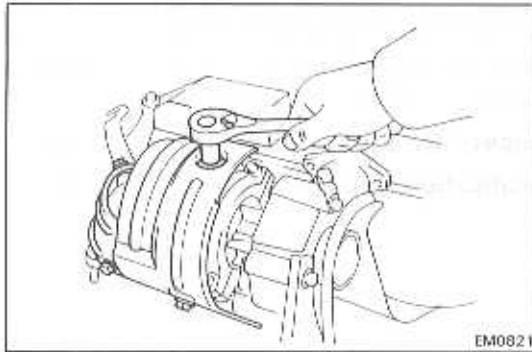

EM0821

4. REMOVE TURBOCHARGER HEAT INSULATORS

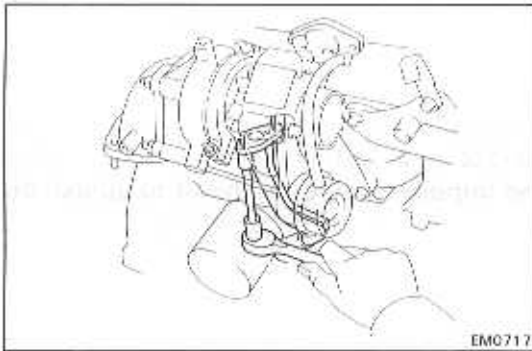

EM0717

5. REMOVE TURBOCHARGER OIL PIPE FLANGE NUTS

Remove the two nuts and oil deflector.

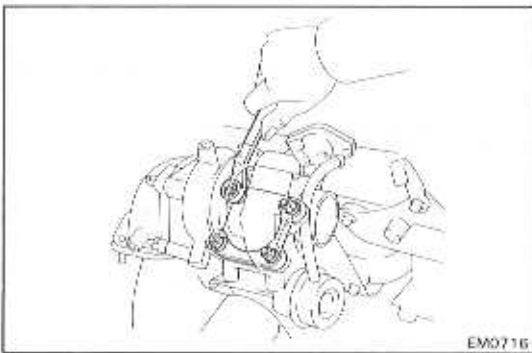

EM0716

6. REMOVE TURBOCHARGER FROM EXHAUST MANIFOLD

Remove the four nuts and remove the turbocharger, gasket and oil pipe gasket.

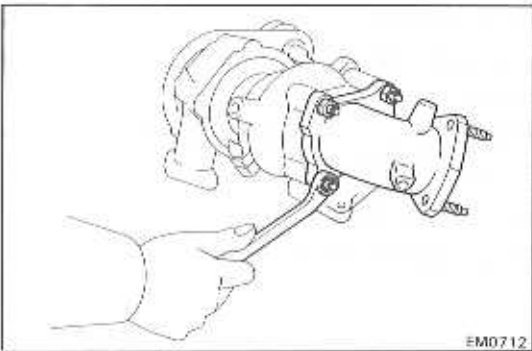

EM0712

7. REMOVE TURBINE ELBOW

Remove the four nuts, washers, turbine elbow and gasket.

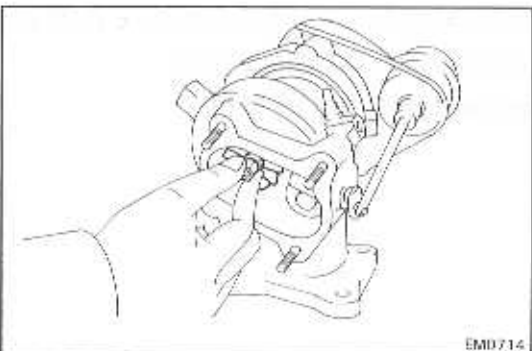

EM0714

INSPECTION OF TURBOCHARGER

1. INSPECT IMPELLER WHEEL ROTATION

Grasp the edge of the turbine wheel and turn it. Check that the impeller wheel turns smoothly.

If the impeller wheel does not turn or if it turns with a drag, replace the turbocharger assembly.

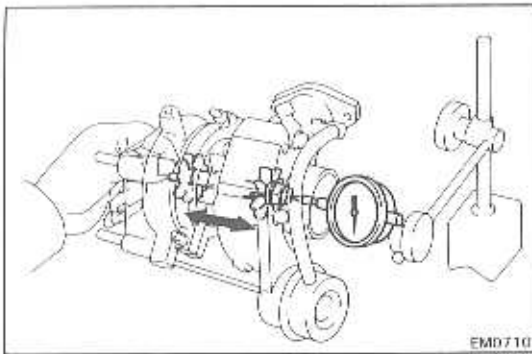

EM0710

2. INSPECT AXIAL PLAY OF SHAFT BEARING

Insert a dial gauge into the intake side, hold the turbine wheel edge by hand and check the axial play.

Standard clearance: 0.13 mm (0.0051 in.) or less

If not within specification, replace the turbocharger assembly.

INSTALLATION OF TURBOCHARGER

(See page EM-8)

CAUTION: After replacing a turbocharger assembly, pour about 20 cc (1.2 cu in.) of new oil into the oil inlet and then turn the impeller wheel by hand to splash oil on the bearing.

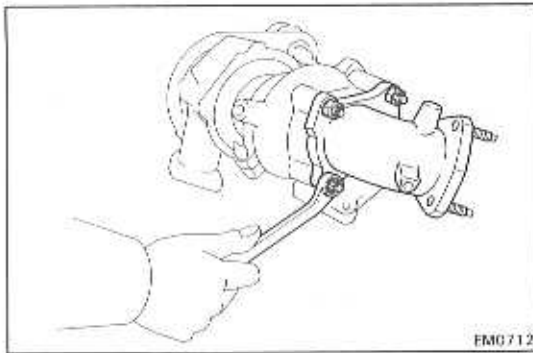

FM0712

1. INSTALL TURBINE ELBOW

Install the gasket and turbine elbow with the four nuts and washers.

Torque: 260 kg-cm (19 ft-lb, 25 N·m)

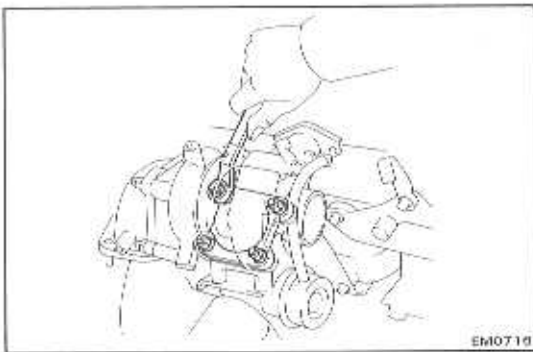

EM0719

2. INSTALL TURBOCHARGER

(a) Place a new gasket with the protrusion on the side of the cylinder head.

(b) Install the turbocharger, with a new oil pipe gasket, to the exhaust manifold and oil pipe.

(c) Install and torque the nuts.

Torque: 530 kg-cm (38 ft-lb, 52 N·m)

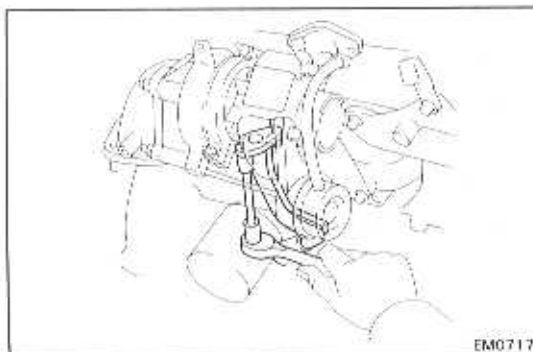

EM0717

3. INSTALL TURBOCHARGER OIL PIPE FLANGE NUTS

(a) Install the oil deflector and flange nuts.

Torque: 195 kg-cm (14 ft-lb, 19 N·m)

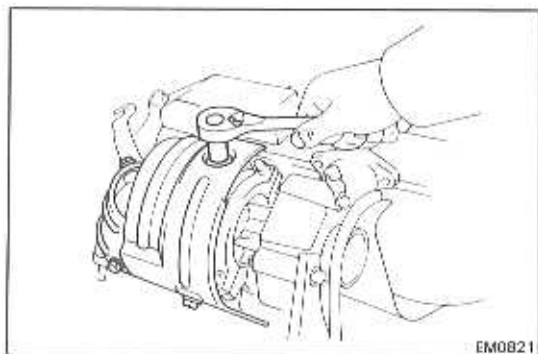

EM0821

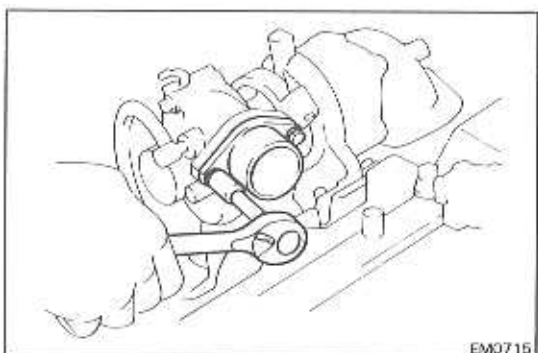
4. INSTALL TURBOCHARGER HEAT INSULATORS

EM0715

5. INSTALL COMPRESSOR ELBOW

Install a new gasket and the compressor elbow with the two bolts. Torque the bolts.

Torque: 120 kg-cm (9 ft-lb, 12 N·m)

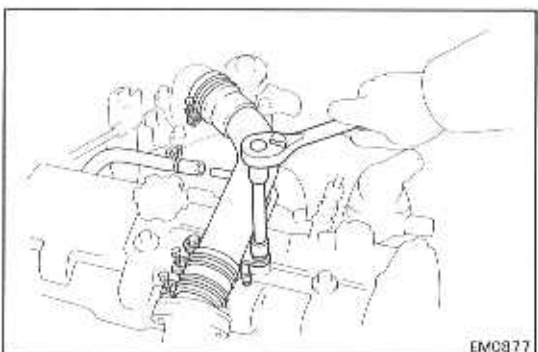

EM0877

6. INSTALL AIR INTAKE PIPE

(a) Install the No. 1 air cleaner hose to the compressor elbow.

(b) Install the air intake pipe with the three clamps and two bolts.

Torque: 120 kg-cm (9 ft-lb, 12 N·m)

(c) Connect the PCV hoses.

7. CONNECT ACCELERATOR CABLE

FUEL SYSTEM

	Page
FUEL HEATER	FU-2
INJECTION PUMP	FU-4

FUEL HEATER SYSTEM CIRCUIT

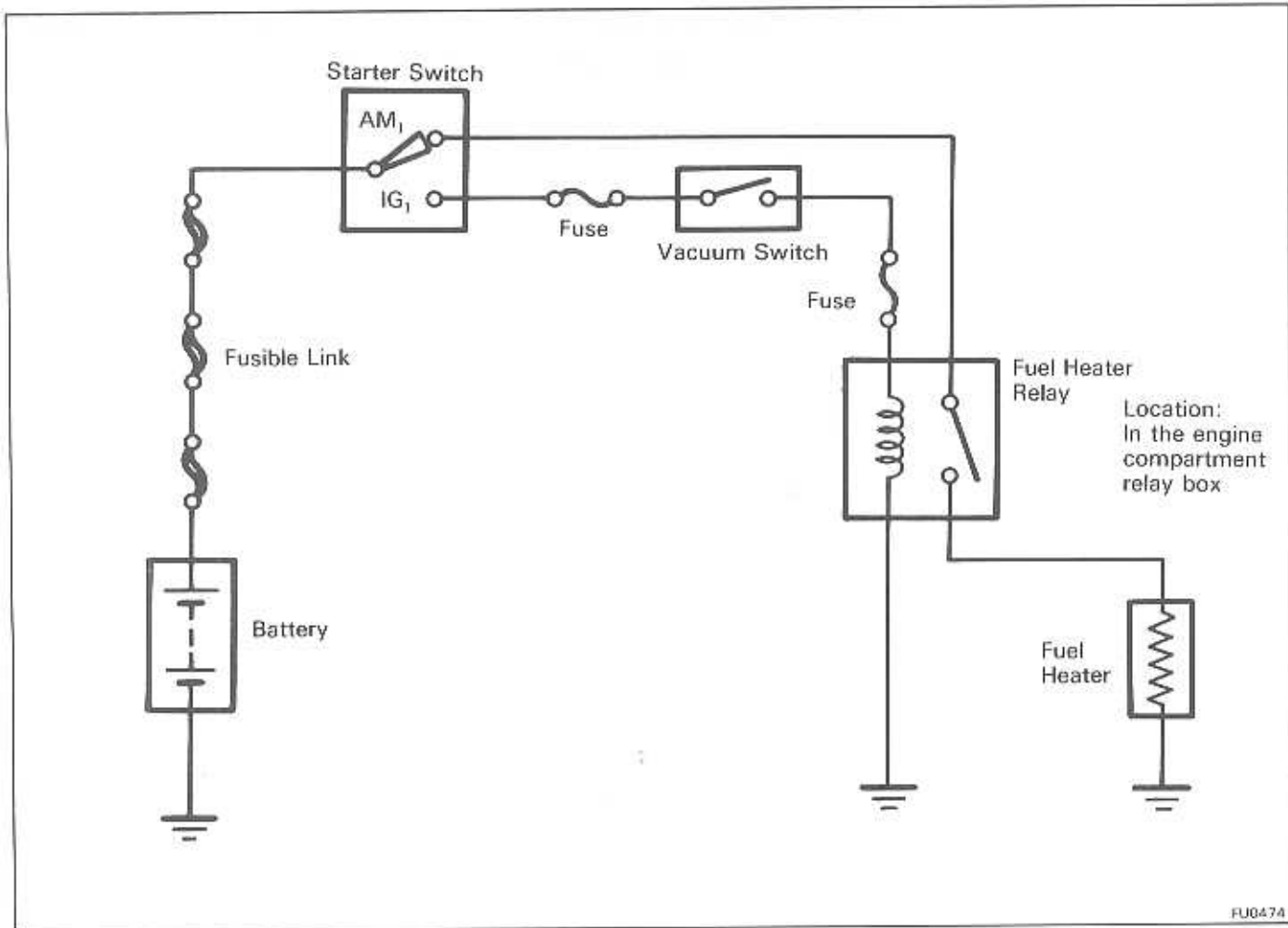

FU0474

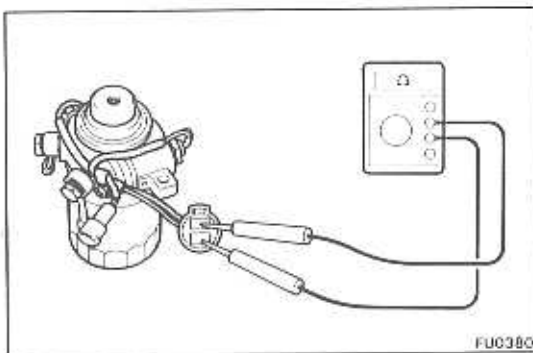

FU0380

INSPECTION OF FUEL HEATER

1. INSPECT FUEL HEATER

Using an ohmmeter, measure the resistance between the terminals.

Resistance: More than 0.7 Ω at 20°C (68°F)

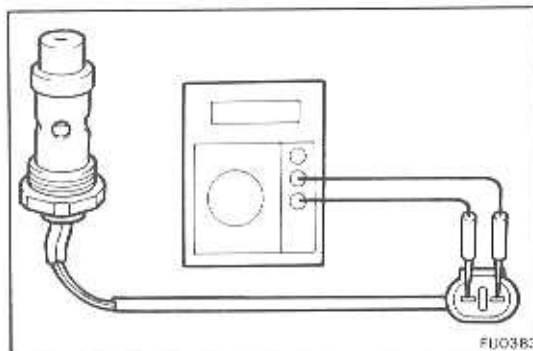

FU0383

2. INSPECT VACUUM SWITCH

(a) Using an ohmmeter, check that there is no continuity between the switch terminal and switch body.

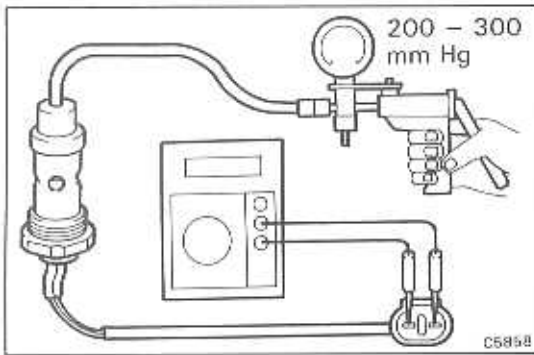

- (b) With a vacuum of 250 ± 50 mmHg (9.84 ± 1.97 in.Hg, 33.3 ± 6.67 kPa) or above. Check that there is continuity between the switch terminal and switch body.

If continuity is not as specified, replace the switch.

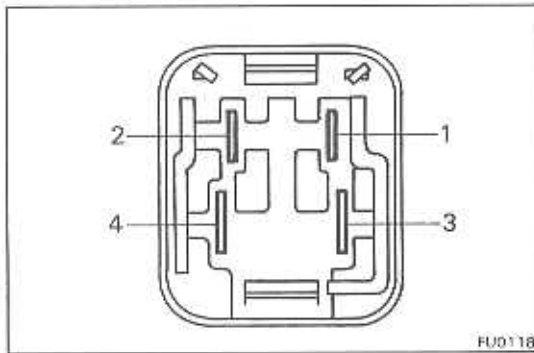

3. INSPECT FUEL HEATER RELAY

LOCATION: In the engine compartment relay box.

- (a) Using an ohmmeter, check for continuity between the following terminals:

- 3 → 4 **Continuity**
- 1 → 2 **No continuity**

- (b) Apply battery voltage between terminals 3 and 4.

- 1 → 2 **Continuity**

If continuity is not as specified, replace the relay.

INJECTION PUMP COMPONENTS

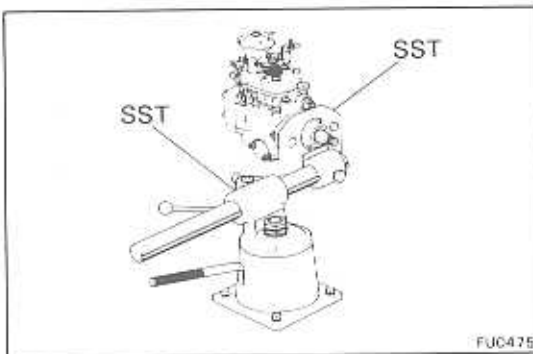
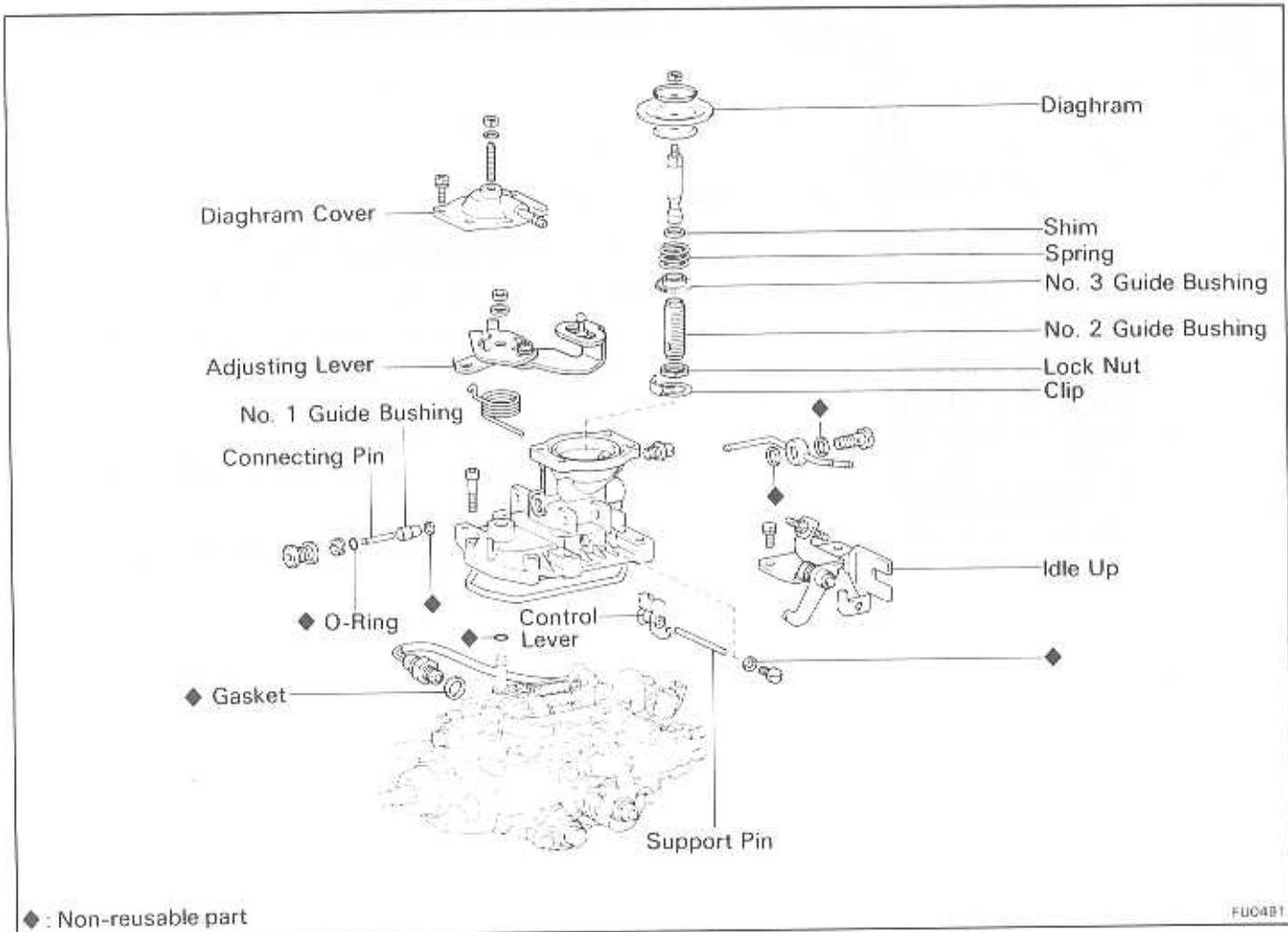

DISASSEMBLY OF BOOST COMPENSATOR

1. MOUNT INJECTION PUMP TO STAND (SST) FOR DISASSEMBLY

SST 09241-76022 and 09245-54010

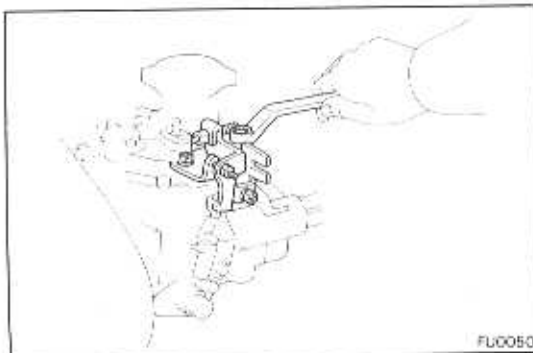

2. REMOVE IDLE-UP

Remove the three bolts and idle-up

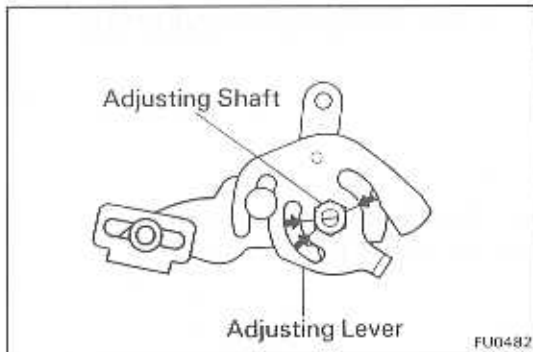

3. REMOVE ADJUSTING LEVER

- (a) Place matchmarks on the governor adjusting shaft and adjusting lever.
- (b) Remove the nut and adjusting lever.

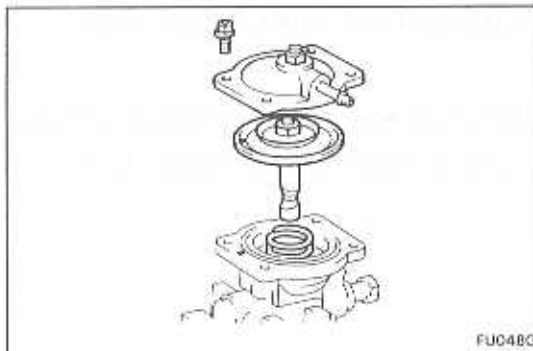

4. REMOVE BOOST COMPENSATOR DIAPHRAGM

- (a) Remove the four bolts and diaphragm cover.
- (b) Remove the diaphragm, boost compensator shim and spring.

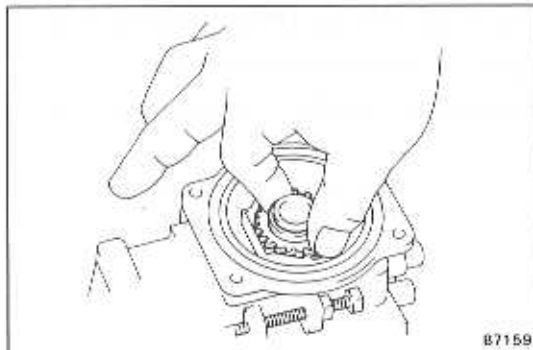

5. REMOVE NO. 3 GUIDE BUSHING

Turn the guide bushing counterclockwise to remove it.

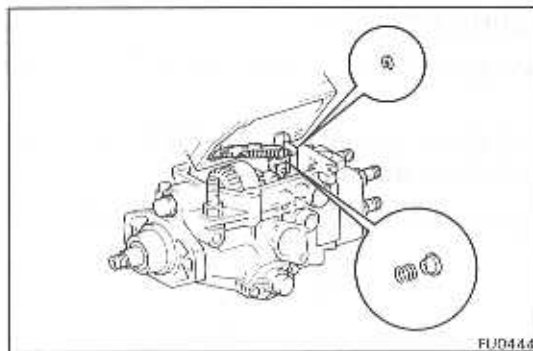

6. REMOVE GOVERNOR COVER

Remove the E-ring, governor spring seat, damper spring and governor spring.

CAUTION: Be careful not to lose the lever support spring.

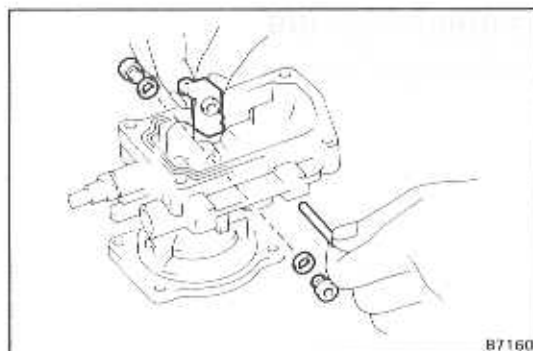

7. REMOVE CONTROL LEVER FROM GOVERNOR COVER

- (a) Using an allen wrench, remove the two bolts and the gaskets.
- (b) Remove the support pin and control lever.

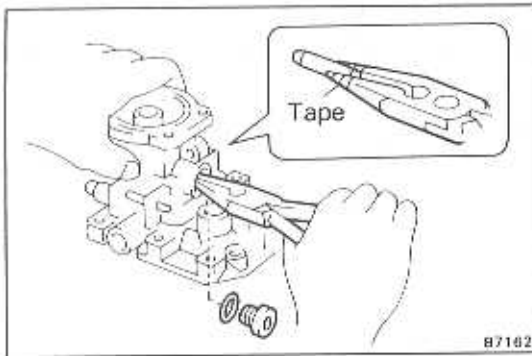

8. REMOVE CONNECTING PIN FROM GOVERNOR COVER

- (a) Using an allen wrench, remove the screw plug with the gasket.
- (b) Using pliers, pull out the connecting pin.

CAUTION: Tape the tip of the pliers, and be careful not damage the connecting pin.

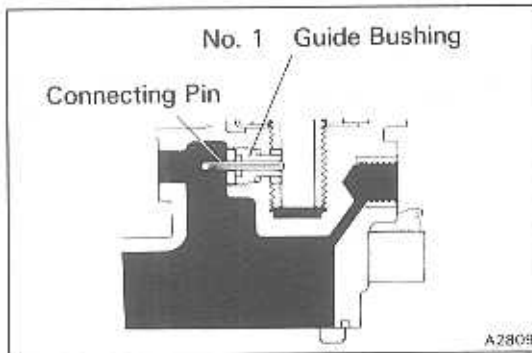

ASSEMBLY OF BOOST COMPENSATOR

(See page FU-4)

1. INSTALL CONNECTING PIN TO GOVERNOR COVER

Insert the connecting pin into the No. 1 guide bushing.

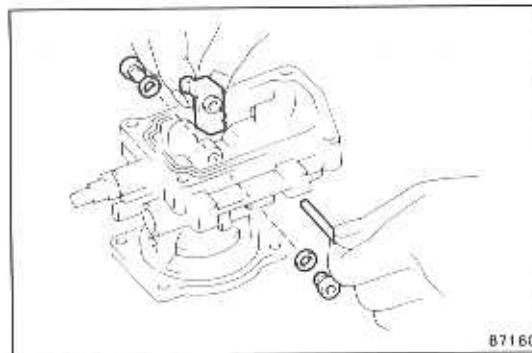

2. INSTALL CONTROL LEVER TO GOVERNOR COVER

- (a) Install the control lever and support pin.
- (b) Using an allen wrench, install the two bolts with the gaskets.

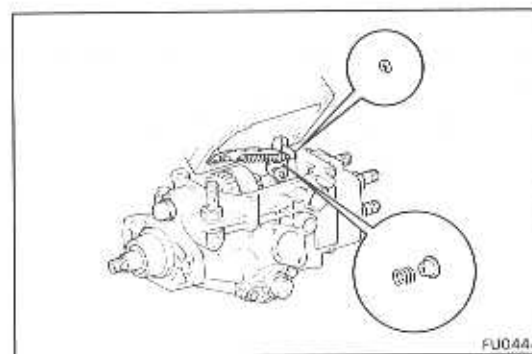

3. INSTALL GOVERNOR COVER

- (a) Install a new gasket into the groove of the governor cover.
- (b) Install the damper spring and governor spring seat and connect them with the E-ring.
- (c) Install the governor cover with the four bolts.

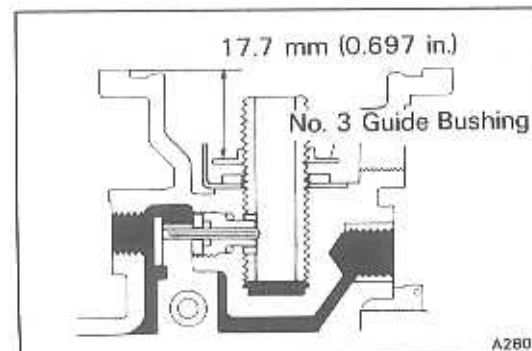

4. INSTALL NO. 3 GUIDE BUSHING

Install and adjust the guide bushing as shown.

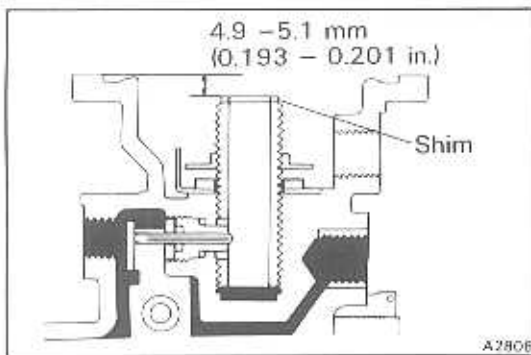

5. SELECT BOOST COMPENSATOR SHIMS

- Place the shims on the No. 2 guide bushing.
- Using calipers, measure the dimension as shown.

If the dimension is not within specification, select and install the correct shims.

NOTE: Shims are available in 8 sizes, in increments of 0.2 mm (0.008 in.), from 1.9 mm (0.075 in.) to 3.3 mm (0.130 in.).

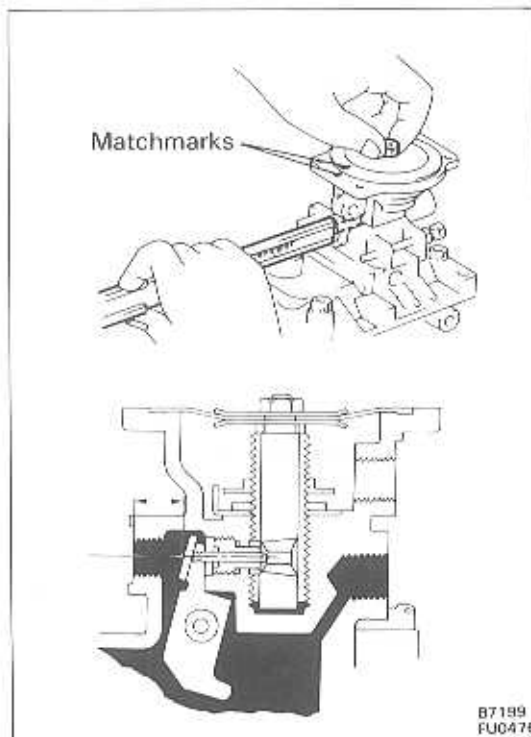

6. ADJUST BOOST COMPENSATOR DIAPHRAGM

- Install the shims and diaphragm.

NOTE: Do not assemble the spring.

- While pushing on the diaphragm, measure dimension "X" with calipers as shown.

Dimension "X": 8.3 - 8.5 mm (0.327 - 0.335 in.)

NOTE: Measure at the center of the hole.

If dimension "X" is not within specification, turn the diaphragm.

- Place matchmarks on the diaphragm and housing.
- Remove the diaphragm.
- Using an allen wrench, install the screw plug with the gasket.

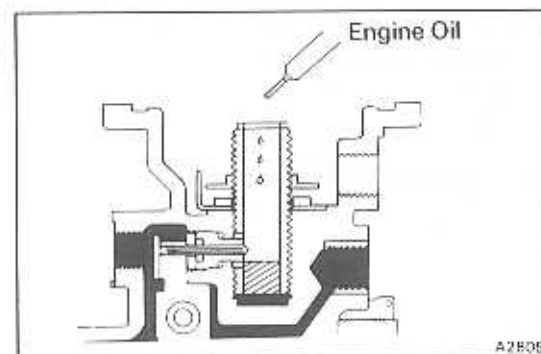

7. INSTALL BOOST COMPENSATOR DIAPHRAGM

- Insert 3 - 4 cc (0.18 - 0.24 cu in.) of engine oil into the No. 2 guide bushing.

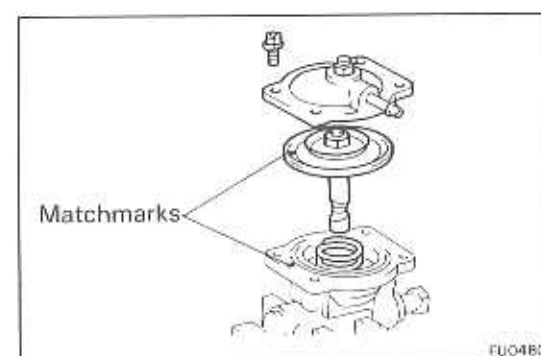

- Install the shims, spring and diaphragm.
- Align the matchmarks on the diaphragm and housing.
- Install the diaphragm cover with four bolts.

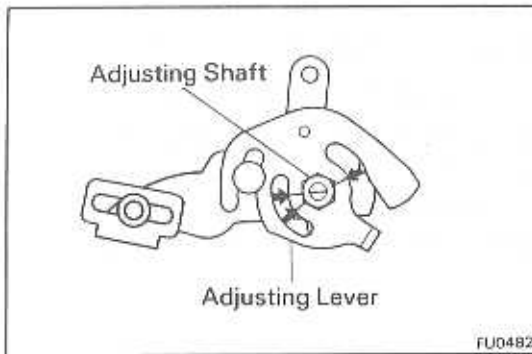
**8. INSTALL ADJUSTING LEVER**

Align the matchmarks on the governor adjusting shaft and adjusting lever. Install and torque the nut.

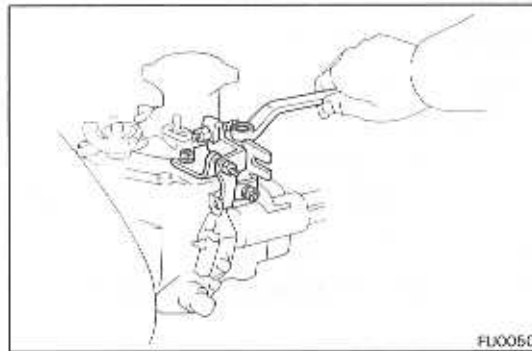
**9. INSTALL IDLE UP**

Install the idle up with three bolts.

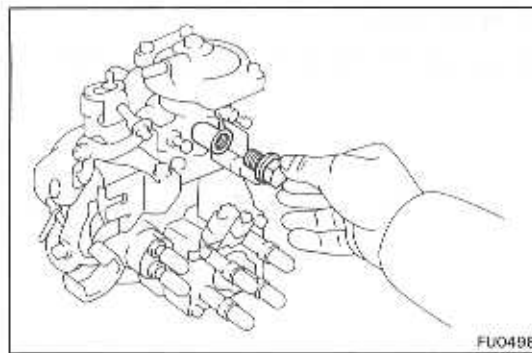
**10. PERFORM AIR TIGHT TEST**

(a) Replace the overflow screw with a bolt.

(b) Connect an air hose to the fuel inlet hole and submerge the injection pump in diesel fuel.

(c) Apply 1.5 kg/cm^2 (21 psi, 147 kPa) of pressure and confirm that there are no leaks.

(d) Next check that there are no leaks with 5.0 kg/cm^2 (71 psi, 490 kPa) of pressure applied.

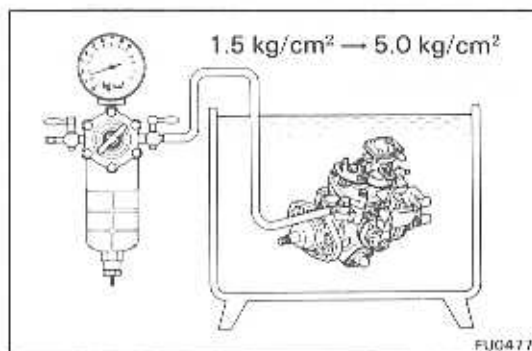

SERVICE SPECIFICATIONS

	Page
ENGINE MECHANICAL	A-2
FUEL SYSTEM	A-2

ENGINE MECHANICAL**Specifications**

Turbocharging pressure		0.41 – 0.54 kg/cm ² (5.8 – 7.7 psi, 40 – 53 kPa)	
Turbocharger	Bearing shaft axial play	0.13 mm or less	(0.0051 in.)

Torque Specifications

Part tightend	kg-cm	ft-lb	N-m
Turbine elbow x Turbocharger	260	19	25
Exhaust manifold x Turbocharger	530	38	52
Turbocharger oil pipe x Turbocharger	195	14	19
Compressor elbow x Turbocharger	120	9	12

FUEL SYSTEM

Fuel heater	Fuel heater resistance at 20°C (68°F)	More than 0.7 Ω
-------------	--	-----------------